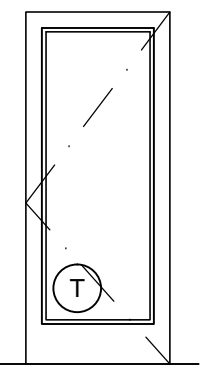
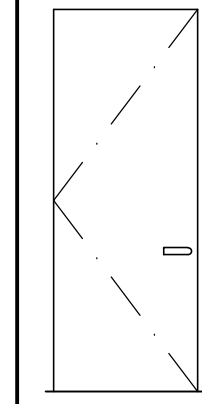
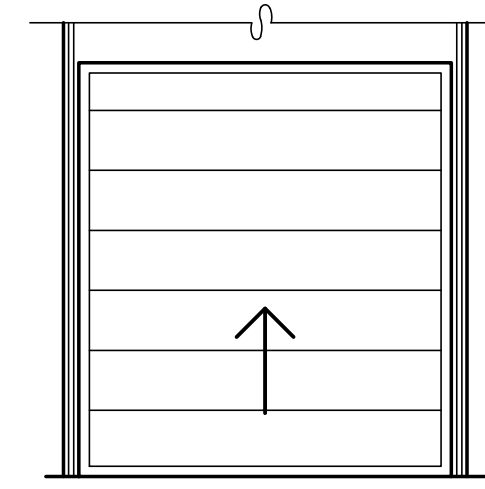

**PROPOSED  
BUILDING  
939,660 SF**

**FLOOR PLAN**  
SCALE: 1"=50'-0"

**DOOR TYPES**

<p><b>(A)</b> ALUMINUM STOREFRONT 3'-0" x 8'-0" CLEAR ANOD. ALUM. STOREFRONT DOOR W/TEMPERED GLAZING (NARROW STILE) FRAME: MANUF</p> 	<p><b>(B) (B1)</b> HOLLOW METAL 3'-0" x 7'-0" (4'-0" x 7'-0" @ B1) PAINTED INSULATED HOLLOW METAL DOOR FRAME: PAINTED HOLLOW METAL</p> 	<p><b>(C) (C1)</b> SECTIONAL O.H. DOOR <b>(C)</b> 9' W X 10' H DOCK HIGH SECTIONAL VERTICAL LIFT OVERHEAD DOOR W/ FACTORY PAINTED FINISH. <b>(C1)</b> 12' W X 14' H SECTIONAL VERTICAL LIFT OVERHEAD DOOR W/ FACTORY PAINTED FINISH.</p> 
--	--	--

**FLOOR PLAN NOTES**

- 1 STRUCTURAL COLUMN, SEE STRUCTURAL DRAWINGS.
- 2 STRUCTURAL CONCRETE SLAB, SEE STRUCTURAL DRAWINGS. PROVIDE VAPOR RETARDER OVER SAND BASE AT OFFICE AREA PER SOLS REPORT. PROVIDE SEALER FOR CONCRETE FLOOR AREA IN WAREHOUSE.

FLOOR PLAN		REMARKS	REMARKS
DATE	PLANNING SUBMITTAL	DATE	REMARKS
05/17/21			

PA / PM: RAYMOND LEE  
DRAWN BY: ERIC KAUFFMAN  
JOB NO:

SHEET  
**A2.1**

**WARE, MALCOLM**  
Leading Design for Commercial Real Estate

architecture  
planning  
graphics  
civil engineering  
2400 Camino Ramon, Suite 390  
San Ramon, California 94583  
P: 925.244.9621

**PACIFIC BUSINESS  
CENTER**  
MANTECA, CALIFORNIA

**PACIFIC BUSINESS  
CENTER**  
MANTECA, CALIFORNIA