



Western Water Constructors, Inc.
Submittal Cover

Job no. 16-05



CONTRACT NAME: Manteca WQCF Digester Improvements
SPEC SECTION: 15520 Tankless Water Heaters and Hot Water Pressure Washers
SUBMITTAL TITLE: Hot Water Pressure Washer - O&M
FILE NAME: 211-R0\_15520-06\_Hot Water Pressure Washer-OM

SUB #: 211
REV #: 0
CODE: 15520-06
DATE: 11/15/2017

WWC REVIEW/COMMENTS: [X] NO EXCEPTIONS [ ] EXCEPTIONS / DEVIATIONS AS NOTED

REVIEWED BY: ST

SIGNED: [Signature]

WWC HAS REVIEWED THIS SUBMITTAL FOR CONFORMANCE WITH THE PROJECT PLANS & SPECIFICATIONS.

OWNER REVIEW:

Table with columns: ITEM, DESCRIPTION, REVIEW STATUS (A, B, C, D, E). Row 1: Hot Water Pressure Washer O&M, A: [ ], B: [ ], C: [ ], D: [ ], E: [ ]

LEGEND: A = No Exceptions Taken B = Make Correction Noted C = Correct & Resubmit
D = Rejected E = Accepted for Record

OWNER COMMENTS:

REVIEWER'S NAME: \_\_\_\_\_

REVIEWER'S SIGNATURE: \_\_\_\_\_

DATE: \_\_\_\_\_

EQUIPMENT SUMMARY FORM

1. EQUIPMENT ITEM HOT WATER PRESSURE WASHER
2. MANUFACTURER LANDA
3. EQUIPMENT IDENTIFICATION NUMBER(S) FOG-HTR-07-704  
(maps equipment number)
4. LOCATION OF EQUIPMENT FOG RECEIVING AREA
5. WEIGHT OF INDIVIDUAL COMPONENTS (OVER 100 POUNDS) SHIP WEIGHT IS 1,030 LBS.  

---

---
6. NAMEPLATE DATA - Horsepower 8.2 hp.  
Amperage 15A  
Voltage 460v 3 Phase  
Service Factor (S.F.) \_\_\_\_\_  
Speed 775 rpm.  
ENC Type \_\_\_\_\_  
Capacity 3.9 gpm.  
Other \_\_\_\_\_
7. MANUFACTURER'S LOCAL REPRESENTATIVE  
Name PRESSURE WASHER REPAIR CENTER / AIRLESS REPAIR CENTER  
Address 2201 Bluebell Dr. Unit C, Santa Rosa, CA 95403  
Telephone  
Number 707-527-0118
8. MAINTENANCE REQUIREMENTS See O&M.  

---

---
9. LUBRICANT LIST N/A  

---

---
10. SPARE PARTS (recommendations) N/A  

---

---
11. COMMENTS N/A  

---

---

# LANDA® VNG

## OPERATOR'S MANUAL

---

### VNG4-2000

- VNG4-20024A 1.109-563.0
- VNG4-20024B 1.109-564.0
- VNG4-20024C 1.109-565.0
- VNG4-20024H 1.109-568.0

### VNG4-3000

- VNG4-30024A 1.109-569.0
- VNG4-30024B 1.109-570.0
- VNG4-30024C 1.109-571.0
- VNG4-30024H 1.109-574.0

### VNG6-3000

- VNG6-30024B 1.109-575.0
- VNG6-30024C 1.109-576.0

### VNG8-3000

- VNG8-30024B 1.109-579.0
- VNG8-30024C 1.109-580.0
- VNG8-30024H 1.109-582.0

### VNG10-2000

- VNG10-20024B 1.109-559.0
  - VNG10-20024C 1.109-560.0
- 



---

For technical assistance or the dealer nearest you,  
consult our web page at [www.landa.com](http://www.landa.com)

# CONTENTS

---

Introduction & Important Safety Information	4-6
Component Identification	7
Installation	8-12
Location	8
Gas Codes	8
Electrical	8
Gas Piping	8,10
Installation Guide	9
Propane Gas	10
Natural Gas	10
Venting	10
Draft Diverter	10
Water Source	11
Water Connection	11
Inspecting & Testing Gas Piping	11
Gas Pressure	11
Warning and Check Lists	12
Operation Instructions	13
General Cleaning Techniques	14
Maintenance	15-18
Troubleshooting Guides	19-23
VNG-S Exploded Views	24-25
VNG-S Parts List	26-27
VNG-L Exploded Views	28-29
VNG-L Parts List	30-31
Control Panel Assembly	32
Control Panel Parts List	33
VNG-L 6-3000, 8-3000 Burner Assembly	34
VNG-L 6-3000, 8-3000 Burner Parts List	35

VNG-L 10-2000 Burner Assembly	36
VNG-L 10-2000 Burner Parts List	37
VNG Electrical Box Auto Start	38
VNG Electrical Box Auto Start Parts List	39
VNG Electrical Box Time Delay & Parts List	40
VNG Remote Electrical Box	41
VNG Handheld Wireless Exploded View & Parts List	42
VNG Handheld Wireless Operating Instructions	43
VNG 4-2000, 4-3000, 6-3000 Pump Assembly	44
VNG 4-2000, 4-3000, 6-3000 Pump Assembly Parts List	45
VNG 8-3000, 10-2000 Pump Assembly	46
VNG 8-3000, 10-2000 Pump Assembly Parts List	47
VNGL Float Tank & Parts List	48
Hose and Spray Gun Assembly	49
Parts Specifications, Landa Pump	50-51
Burner Specifications	52
Basic Facts	53
Pressure Equivalents	53
VRT 3 Unloader Exploded View and Parts List	54
VBXL Unloader Exploded View and Parts List	55
VB8 Valve Exploded View and Parts List	56-57
LT Pump Exploded View and Parts List	58-59
LX Pump Exploded View and Parts List	60-61

## Warranty

Model Number \_\_\_\_\_

Serial Number \_\_\_\_\_

Date of Purchase \_\_\_\_\_

The model and serial numbers will be found on a decal attached to the pressure washer. You should record both serial number and date of purchase and keep in a safe place for future reference.

# INTRODUCTION & IMPORTANT SAFETY INFORMATION

Thank you for purchasing this Pressure Washer. We reserve the right to make changes at any time without incurring and obligation.

## Owner/User Responsibility:

The owner and/or user must have an understanding of the manufacturer's operating instructions and warnings before using this pressure washer. Warning information should be emphasized and understood. If the operator is not fluent in English, the manufacturer's instructions and warnings shall be read to and discussed with the operator in the operator's native language by the purchaser/owner, making sure that the operator comprehends its contents.

Owner and/or user must study and maintain for future reference the manufacturers' instructions.

The operator must know how to stop the machine quickly and understand the operation of all controls. Never permit anyone to operate the engine without proper instructions.

## SAVE THESE INSTRUCTIONS

This manual should be considered a permanent part of the machine and should remain with it if machine is resold.

When ordering parts, please specify model and serial number. Use only identical replacement parts.

This machine is to be used only by trained operators.

## IMPORTANT SAFETY INFORMATION

**WARNING:** If you do not follow these instructions exactly, a fire or explosion may result, causing property damage, personal injury or loss of life.

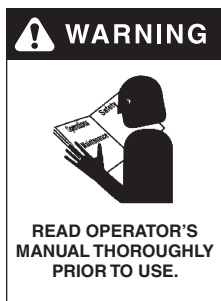

**WARNING:** To reduce the risk of injury, read operating instructions carefully before using.

1. Read the owner's manual thoroughly. Failure to follow instructions and warnings could cause malfunction of the machine and result in death, serious bodily injury and/or property damage.
2. Know how to stop the machine and bleed pressure quickly. Be thoroughly familiar with the controls.
3. Stay alert — watch what you are doing.
4. Use only your hand to push in or turn the gas control knob. Never use a tool. If the knob will not push in or turn by hand, don't try to repair it; call a qualified service technician.

5. All installations must comply with local codes. Contact your electrician, plumber, utility company or the selling distributor for specific details. If your machine is rated 250 volts or less, single phase will be provided with a ground fault circuit interrupter (GFCI). If rated more than 250 volts, or more than single phase this product should only be connected to a power supply receptacle protected by a GFCI.

**DANGER: Improper connection of the equipment-grounding conductor can result in a risk of electrocution. Check with a qualified electrician or service personnel if you are in doubt as to whether the outlet is properly grounded. Do not modify the plug provided with the product - if it will not fit the outlet, have a proper outlet installed by a qualified electrician. Do not use any type of adaptor with this product.**



**WARNING:** Keep wand, hose, and water spray away from electric wiring or fatal electric shock may result.

6. To protect the operator from electrical shock, the machine must be electrically grounded. It is the responsibility of the owner to connect this machine

to a UL grounded receptacle of proper voltage and amperage ratings. Do not spray water on or near electrical components. Do not touch machine with wet hands or while standing in water. Always disconnect power before servicing.

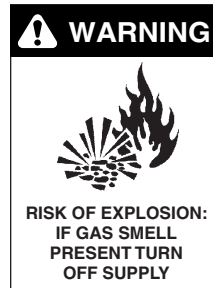

**WARNING: Flammable liquids can create fumes which can ignite, causing property damage or severe injury.**

**WARNING: Risk of explosion — Operate only where open flame or torch is permitted. Do not spray flammable liquids.**



**WARNING: Risk of fire — Do not change tanks when the product is operating or still hot.**

**WARNING: Use vapor fuel only.**

7. Gas appliances shall be installed only in locations where combustible dusts and flammable gases or vapors are not present. Do not store or use gasoline near this machine.

8. Keep operating area clear of all persons.

# IMPORTANT SAFETY INFORMATION

**WARNING:** In the event of a pilot outage, wait at least five minutes to clear out any gas before re-lighting.

**! WARNING**



USE PROTECTIVE EYE WEAR

**WARNING:** High pressure spray can cause paint chips or other particles to become airborne and fly at high speeds. To avoid personal injury, eye, hand and foot safety devices must be worn.

**! WARNING**



RISK OF INJECTION OR SEVERE INJURY TO PERSONS. KEEP CLEAR OF NOZZLE.

**WARNING:** High pressure developed by these machines will cause personal injury or equipment damage. Keep clear of nozzle. Use caution when operating. Do not direct discharge stream at people, or severe injury or death will result.

**! WARNING**



EAR PROTECTION MUST BE WORN

9. Eye, hand, and foot protection must be worn when using this equipment.

**WARNING:** This machine exceeds 85 db appropriate ear protection must be worn.

**! WARNING**



PROTECT FROM FREEZING

**WARNING:** Protect machine from freezing.

13. To keep machine in best operating conditions, it is important you protect machine from freezing. Failure to protect machine from freezing could cause malfunction of the machine and result in death, serious bodily injury, and/or property damage. Follow storage instructions specified in this manual.

**! CAUTION**



HOT DISCHARGE FLUID: DO NOT TOUCH OR DIRECT DISCHARGE STREAM AT PERSONS.

**CAUTION:** Hot discharge fluid. Do not touch or direct discharge stream at persons.

**WARNING:** This machine produces hot water and must have insulated components attached to protect the operator.

**! WARNING**



RISK OF ASPHYXIATION. USE THIS PRODUCT ONLY IN A WELL VENTILATED AREA.

**WARNING:** Risk of asphyxiation. Use this product only in a well ventilated area.

14. Avoid installing machines in small areas or near exhaust fans. Adequate oxygen is needed for combustion or dangerous carbon monoxide will result.

**! WARNING**



RISK OF INJURY. HOT SURFACES CAN CAUSE BURNS

**WARNING:** Risk of injury. Hot surfaces can cause burns. Use only designated gripping areas of spray gun and wand. Do not place hands or feet on non-insulated areas of the pressure washer.

15. Manufacturer will not be liable for any changes made to our standard machines or any components not purchased from us.

16. The best insurance against an accident is precaution and knowledge of the machine.

10. To reduce the risk of injury, close supervision is necessary when a machine is used near children. Do not allow children to operate the pressure washer. This machine must be attended during operation.

**! WARNING**



RISK OF INJURY FROM FALLS WHEN USING LADDER.

**WARNING:** Be extremely careful when using a ladder, scaffolding or any other relatively unstable location. The cleaning area should have adequate slopes and drainage to reduce the possibility of a fall due to slippery surfaces.

**! WARNING**

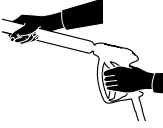

TRIGGER GUN KICKS BACK - HOLD WITH BOTH HANDS

**WARNING:** Grip cleaning wand securely with both hands before starting. Failure to do this could result in injury from a whipping wand.

11. Never make adjustments on machine while in operation.
12. Be certain all quick coupler fittings are secured before using pressure washer

17. Do not overreach or stand on unstable support. Keep good footing and balance at all times.

18. Do not operate this machine when fatigued or under the influence of alcohol, prescription medications, or drugs.

19. Follow the maintenance instructions specified in the manual.

## IMPORTANT SAFETY INFORMATION

**WARNING: Use vapor fuel only.**

- 20. The LP models are designed to run on vapor propane fuel. Do not use liquid fuel. Have a qualified serviceman install and service your equipment.
- 21. Never expose a spark or flame where there may be unburned gas present.
- 22. Install this machine about 2 feet from wall to provide adequate ventilation and servicing space. This equipment incorporates parts such as snap switches or similar parts that tend to produce arcs or sparks. Therefore, when located in a garage, it should be in a room or enclosure provided for the purpose or should be installed 18" (457mm) or more above the floor.

**WARNING: To reduce the risk of electric shock, disconnect all electrical connections and shut-off gas valve before servicing.**

- 23. Install this machine on non combustibile flooring.
- 24. Do not allow acids, caustic or abrasive fluids to pass through the pump.
- 25. Never run pump dry or leave spray gun closed longer than 3 minutes.

**WARNING: If connection is made to potable water supply, a back flow device must be provided.**

- 26. Exhaust gases should not be vented into a wall, a ceiling or a concealed space of a building. A draft diverter must be installed to prevent down draft and to allow cooling of exhaust temperatures. Down draft diverters shall be installed in the vents and located at a distance from the pressure washer stack to achieve maximum draft of 36" minimum. Exhaust gases that exceed 470°F (243°C) are not suitable for connection to Type B gas vents.

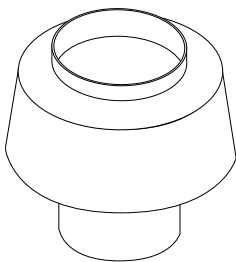

Example of Down Draft Diverter for Gas Fired Machines



**Follow the maintenance instructions specified in the manual.**

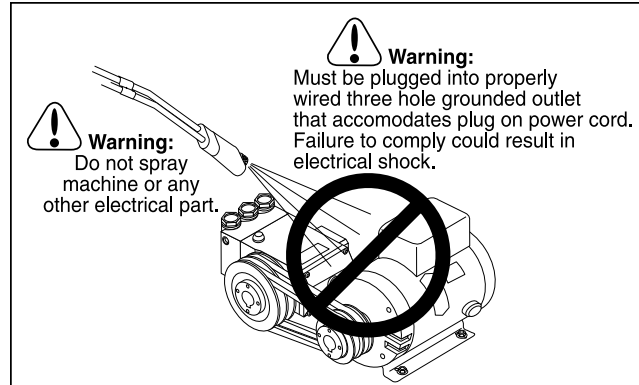

# COMPONENT IDENTIFICATION

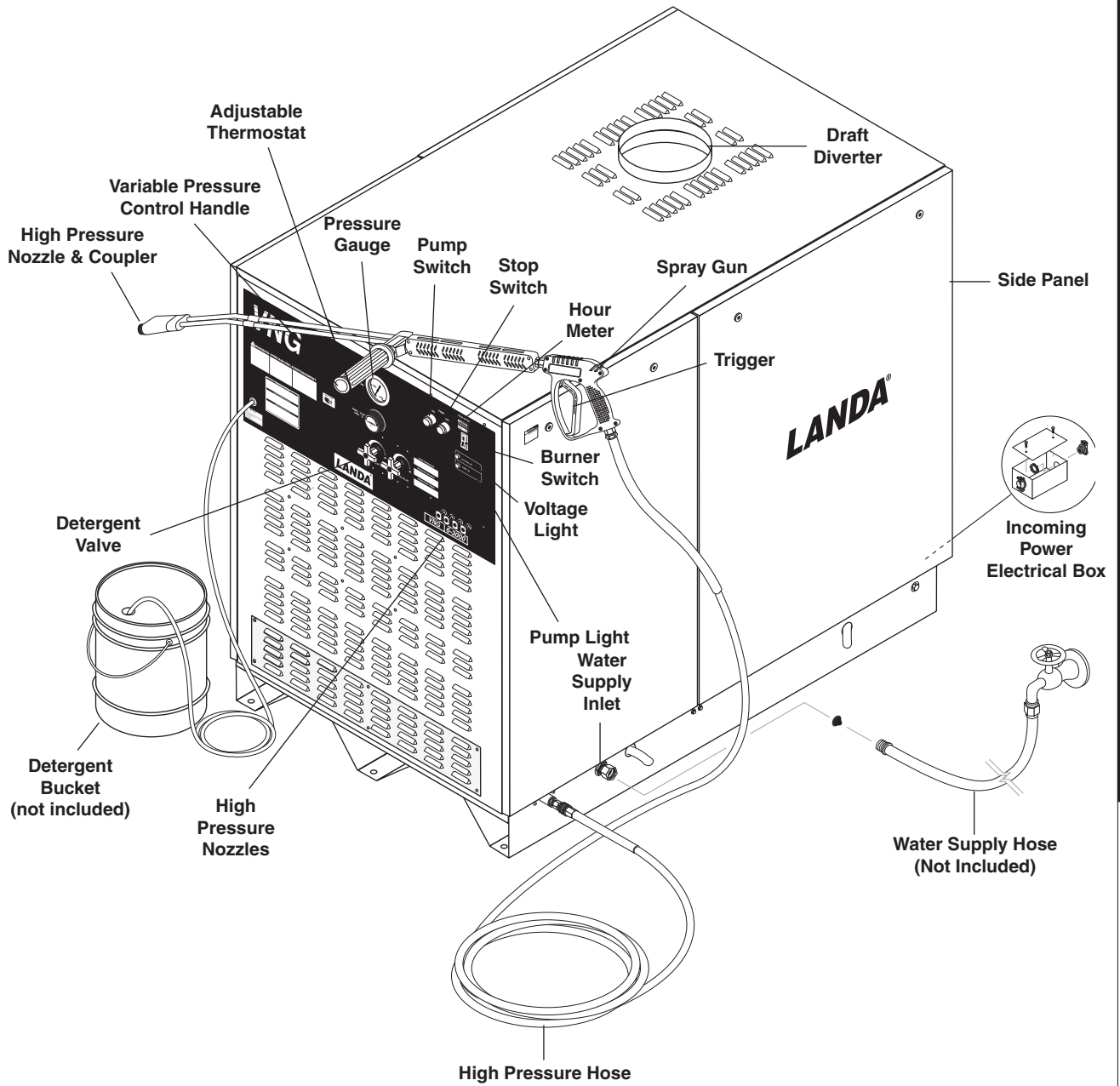

## INSTALLATION

Place machine in a convenient location providing ample support, drainage and room for maintenance (pgs 8-9).

### Location:

The location should protect machine from damaging environmental conditions, such as wind, rain and freezing.

1. The machine should be run on a level surface where it is not readily influenced by outside sources such as strong winds, freezing temperatures, rain, etc. The machine should be located considering accessibility for the replacing of components and the refilling of detergents, adjustments and maintenance. Normal precautions should be taken by the operator of the machine to prevent excess moisture from reaching the machine.
2. It is recommended that a partition be made between the wash area and machine to prevent direct spray from the spray gun from coming in contact with the machine. Excess moisture reaching the power unit or electrical controls will reduce the machine's life and may cause electrical shorts.
3. During installation of the machine, beware of poorly ventilated locations or areas where exhaust fans may cause an insufficient supply of oxygen. Sufficient combustion can only be obtained when there is a sufficient supply of oxygen available for the amount of fuel being burned. If it is necessary to install a machine in a poorly ventilated area, outside fresh air may have to be piped to the burner and a fan installed to bring the air into the area.
4. Do not locate near any combustible material. Keep all flammable material at least 20 feet away.
  - Allow enough space for servicing the machine.
  - Local code will require certain distances from floor and walls. (Two feet away should be adequate).

**WARNING: Avoid small areas or near exhaust fans.**

### Gas Codes:

Confer with local gas company and with proper municipal officials regarding any specific code or regulations governing the installation. The installation must conform to local codes (NFPA 54).

### Electrical:

The machine, when installed, must be electrically grounded in accordance to local codes. Check for proper power supply using a volt meter; check the serial plate for the correct requirements.

### Gas Piping:

This machine shall be rigidly connected to the gas piping outlet and equipped with external manual shut-off valves adjacent to such machine. All gas piping shall

be approved and installed in accordance with the Uniform Mechanical Code.

Install a gas union in the gas line adjacent to and upstream from the control manifold and downstream from the manual main shut-off valve. A 1/8" NPT plugged tapping accessible for test gauge connection shall be installed immediately upstream of the gas supply connection for the purpose of determining the gas supply pressure to the burner, and to prevent damage to gas valve.

If a manual gas shut off valve is not in the gas supply line within six feet of the machine and in an accessible location, one shall be installed.

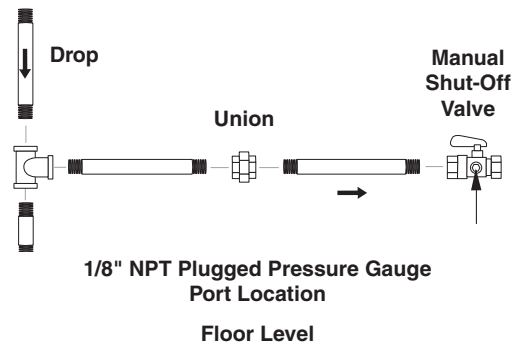

**Figure 1: Union Location**

### Union Connection

The following pipe sizes are just recommendations. Always consult a local plumber and venting contractor for local codes and regulations during installation.

### Pipe Sizing Chart for Natural Gas

The following chart is based on gas pressure in the range 0-0.5 psi, specific gravity of 0.6 and pressure loss of 0.5" W.C. Numbers are for straight schedule 40 pipe; fittings further reduce capacity. For example, in 1" size, an elbow is equivalent to about 2.6 feet of pipe and a tee is equivalent to about 5.2 feet of pipe.

# INSTALLATION

## VNG4-2000, 4-3000, 4-4000

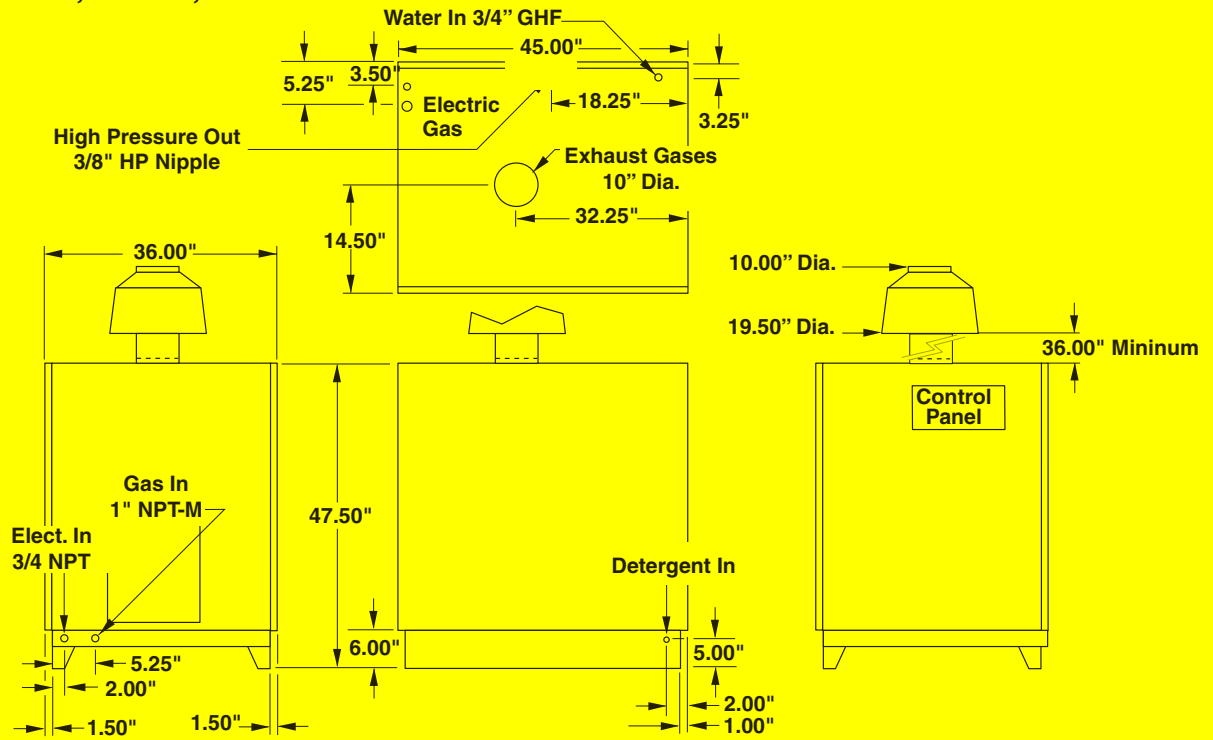

## VNG6-3000, 8-3000, 10-2000

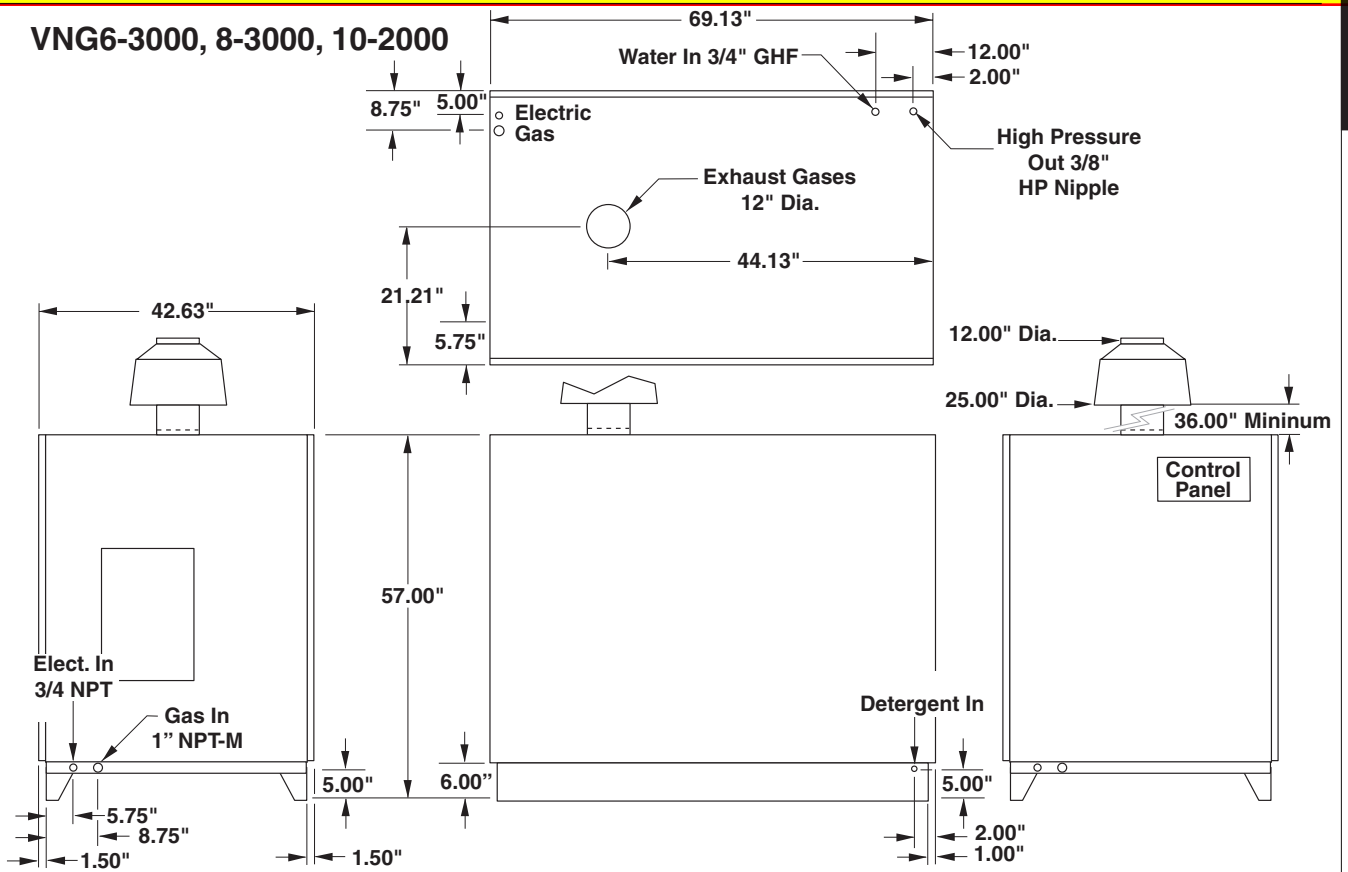

# INSTALLATION

Maximum capacity of pipe in cubic feet/hr of natural gas  
(Multiply values by 1000 to get nominal BTU/hr capacity.)

Length of Pipe (ft.)	Iron Pipe Size				
	3/4"	1"	1 -1/4"	1- 1/2"	2"
10	360	680	1400	2100	3950
20	250	465	950	1460	2750
30	200	375	770	1180	2200
40	170	320	660	990	1900
50	151	285	580	900	1680
60	138	260	530	810	1520
70	125	240	490	750	1400
80	118	220	460	690	1300
90	110	205	430	650	1220
100	103	195	400	620	1150
150	84	160	325	500	950
200	72	135	280	430	800

## LP-Gas (Liquid petroleum gas or propane)

LP-gas is gas compressed into liquid form for easy transportation and storage. It is also known as propane or bottle gas. (Propane tanks are not supplied with this equipment.)

LP-gas is flammable, is always contained under pressure and the liquid can freeze skin. Therefore, in the interest of safety, it is important to understand the basic facts about LP-gas and LP-gas containers.

Federal DOT (Department of Transportation) regulations require periodic inspections and re-qualifications of cylinders. DO NOT USE damaged or rusted containers.

DO NOT store LP-gas containers indoors or in enclosed areas. Do not expose LP-gas container to heat. Always store with service valve closed and plugged as required.

### **CAUTION: Use LP-gas containers in proper position.**

Most LP-gas pressure washer heaters are designed to operate on LP-gas vapor only. Therefore, all LP-gas containers designed for vapor service must be transported, installed and used in the proper position. Do not transport, install or use a vertical cylinder in a horizontal or upside down position. Proper care must be taken to position a horizontal container in the correct position for vapor withdrawal. Liquid LP-gas could enter the system designed for vapor only, possibly creating a hazardous condition.

Always use a POL plug installed on a POL valve or a dust cap on an ACME/Type 1 valve when transporting or storing disconnected containers (full or empty). Check for leaks after connecting. Apply approved leak

detector solution to connection, turn off all burners and pilots and open service valve. Leaks will be detected by the growth of bubbles. If bubbles grow, tighten or repair the connection as needed. Repeat leak test until problem is corrected.

Check all tank and the line connections periodically to be sure they are tight. When testing for leaks, use approved leak detector solution — not matches.

**Improved Regulation:** The second stage regulator receives a relatively uniform pressure from the first stage regulator. This helps the second stage regulator to maintain appliance pressure at a nearly constant 11" W.C.

## Filling the LP-Gas Container

**Only qualified persons should fill your LP-gas containers.**

### **CAUTION: Overfilling is hazardous!**

DO NOT allow your LP-gas container to be overfilled. Stop filling when liquid appears at the fixed level gauge. Bleed off excess propane in a safe area. Most LP-gas containers are equipped with a fixed liquid level gauge which contacts the liquid level at 80% of container capacity, allowing 20% for expansion. LP-gas containers not equipped with a fixed liquid level gauge can only be filled by weight.

In cold climates, in order to keep vaporization of LP-gas at the highest level, keep the fuel levels above 50%.

## Combustion and Ventilation Air

Properly sized vents are vital for the safe and efficient operation of a pressure washer installed in a confined space. When combustion and ventilation air are supplied from inside the building, each opening must have an area of one square inch for every 1,000 BTUH input. When combustion air is supplied from the outside, each opening must have an area of one square inch for every 2,000 BTUH for horizontal ducts and one square inch for every 4,000 BTUH for vertical ducts (refer to NFPA 54). See Figure 3.

The purpose of venting a gas pressure washer is to completely remove all products of combustion and to vent gasses to the outside air without condensation in the vent or spillage at the draft hood (except in cases of downdraft or poor stack conditions). To assure correct venting, use a strong, gas-tight insulated pipe with a cross section equal to that of the flue collar or draft hood outlet and of sufficient vertical height.

During vent installation, avoid sharp turns, long horizontal runs and improper pitches. Maintain proper support of vent connectors and joints, observe clearances from all combustibles and top the vent outlet with an approved cap.

## INSTALLATION

Type "B", due to its temperature rating, can only be used with natural draft pressure washers. A "B" vent is designed for exhaust temperatures not to exceed 470°F (245°C).

All venting installations must conform to local codes. In the absence of local codes, refer to "National Fuel Gas Code" NFPA 54 and be constructed of materials approved by the Uniform Building Code.

Vents penetrating ceilings or walls should be double-wall approved appliance vents and should be one to two inches from combustibles. Vents passing through enclosed spaces and vents exposed to the weather should also be the double-wall type. Sometimes vents have to be built of such great length that they come apart at their joints under their own weight. These should be screwed together at the joints with sheet metal screws, usually three per joint. If the inspector indicates that the vent is too close to combustibles, it may be necessary to chisel away some of the combustible or route the vent pipe around the combustible. The cross-sectional area of any flue shall not be less than the cross-sectional area of the flue vent connection outlet of machine.

**Figure 3: Ventilation**

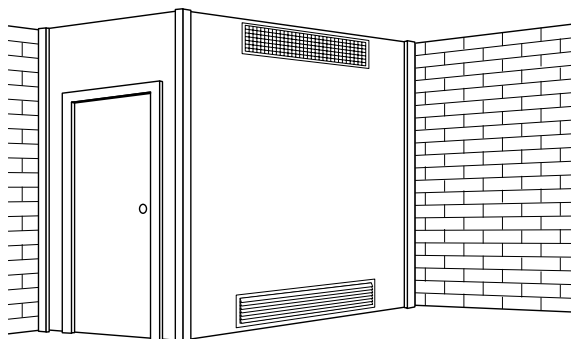

**Illustration showing air openings necessary to supply air for combustion when installed in an enclosed room.**

### Water Source:

The water source for the machine should be supplied by a 5/8" I.D. garden hose with a city water pressure of not less than 30 PSI. If the water supply is inadequate, or if the garden hose is kinked, the machine will run very rough and the burner will not fire.

### Water Connection:

Connect the high pressure hose by pulling the coupler collar back and then inserting it onto the discharge nipple. Secure it by pushing the collar forward.

Attach the wand into the spray gun using teflon tape on the pipe threads to avoid leaks.

### Inspection and Testing Gas Piping:

The building structure should not be weakened by installing the gas piping. The piping should not be

supported by other piping, but should be firmly supported with gas hooks, straps, bands or hangers. Butt or lap welded pipe should not be run through or in an air duct or clothes chute.

Before turning gas under pressure into piping, all openings from which gas can escape should be closed. Immediately after turning on gas, the system should be checked for leaks. This can be done by watching the 1/2 cubic foot test dial for 5 minutes for any movement or by soaping each pipe connection and watching for bubbles. If a leak is found, make the necessary repairs and repeat the above test.

Defective pipes or fittings should be replaced and not repaired. Never use a flame or fire in any form to locate gas leaks — use a soap solution.

After the piping and meter have been checked completely, purge the system of air. **DO NOT** bleed the air inside an enclosed room.

During pressure testing of the system at test pressures in excess of 1/2 PSIG, the pressure washer and its individual shut-off valve must be disconnected from gas supply piping system or damage to the gas valve will occur.

### Gas Pressure:

The ideal incoming gas pressure is 11 w.c.i (water column inches). Minimum is 9 w.c.i., maximum is 14 w.c.i. or 1/2 PSIG. The correct operating manifold pressure for natural gas is 3.5 w.c.i. The operating manifold pressure for propane gas is 10 w.c.i. By adjusting the gas valve pressure regulator between 3 and 4 w.c.i. a side range can be achieved for natural gas.

If the desired input rating cannot be obtained within the above manifold pressure adjusting range, then the next size larger or smaller burner orifice should be used.

The gas pressure coming out of the regulator and going to the burner ring has been factory set for elevations of 0 to 2000 ft. Altitudes greater than 2000 ft will require adjustments to the gas manifold pressures. Consult your local service dealer/distributor for high altitude adjustments. In Canada, certification for installation at altitudes over 4500 feet above sea level is the jurisdiction of local authorities. You should not readjust the burner ring gas pressure. If you replace your gas valve, you will need to adjust the new valve. Refer to your machine's **specification plate** for the correct pressure setting. Follow the installation and adjustment instructions provided with your replacement valve.

**NOTE:** Air for combustion and ventilation along with exhaust flue sizing must conform to methods outlined in current American Standard (ANSI-Z223.1) National Fuel Gas Code or National Standard of Canada CSA-149.1 and CSA-149.2 "Installation Code for Gas Burning Appliances".

# INSTALLATION

## START-UP

### **WARNING**



**READ SAFETY INSTRUCTIONS PRIOR TO INSTALLING OR SERVICING MACHINE.**

**WARNING:** *Read and follow instructions carefully when installing or servicing machine. Failure to do so may result in damage to property or personal injury.*

1. Installation or servicing of gas appliances and controls must only be performed by qualified personnel. After installation or servicing, test the manual valve, operating valves, pressure regulation, and automatic shut-off valve for proper operation.
2. Install in a suitable dry location. Machine must be located in an area properly protected from weather.
3. Shut off gas and electricity before starting installation or service. Turn back on to test or operate.
4. **DO NOT** connect machine before pressure testing the gas piping. Damage to gas valve may result. (9" - 14" W.C.P. or 1/2 PSIG)
5. **DO NOT** insert any object other than suitable pipe or tubing in the inlet or outlet of the gas valve. Internal damage may occur and result in a hazardous condition.
6. **DO NOT** short the gas valve terminals.
7. **DO NOT** grip gas valve body with a pipe wrench or vise. Damage may result causing gas leakage. Use inlet or outlet bosses or a special body wrench.
8. **DO NOT** allow any flame to impinge on the regulator vent tubing if supplied. It may clog and cause gas valve malfunction.
9. **DO NOT** use the gas cock to adjust gas flow.
10. If main burner fails to shut off, turn off gas supply.
11. Keep all combustible materials away from gas appliances. **DO NOT** allow lint or dust to collect in burner area.
12. Dials must only be operated by hand. Never use pliers, wrenches or other tools to turn dials.
13. Leak test with a soap solution after installation or service with the main burner on. Coat pipe and tubing joints, gaskets, etc.

### FOR YOUR SAFETY READ BEFORE LIGHTING

#### WARNING

If you do not follow these instructions exactly, a fire or explosion may result, causing property damage, personal injury or loss of life.

A. This appliance has a pilot which must be lighted by hand. When lighting the pilot, follow these instructions exactly.

B. BEFORE LIGHTING smell all around the appliance area for gas. Be sure to smell next to the floor because some gas is heavier than air and will settle on the floor.

#### "FOR YOUR SAFETY "WHAT TO DO IF YOU SMELL GAS"

- Do not try to light any appliance.
- Do not touch any electrical switch, do not use any phone in your building.
- Immediately call your gas supplier from a neighbor's phone. Follow the gas supplier's instructions.
- If you cannot reach your supplier, call the fire dept.

C. Use only your hand to push in or turn the gas control knob. Never use tools. If the knob will not push in or turn by hand, don't try to repair it; call a qualified service technician. Forced or attempted repair may result in a fire or explosion.

D. Do not use this appliance if any part has been under water. Immediately call a qualified service technician to inspect the appliance and to replace any part of the control system and any gas control which has been under water.

### Check List Before Starting:

**CAUTION!** *If "NO" has been checked on any of the following sixteen questions, do not operate this machine.*

	YES	NO
Has gas supply been inspected by an authorized contractor to meet local codes?	<input type="checkbox"/>	<input type="checkbox"/>
Is machine protected from downdraft and excessive wind?	<input type="checkbox"/>	<input type="checkbox"/>
Is machine shielded from moisture or water spray?	<input type="checkbox"/>	<input type="checkbox"/>
Is the voltage correct and are the circuit breaker and supply cord adequate according to specifications and serial plate notation?	<input type="checkbox"/>	<input type="checkbox"/>
Is the machine electrically grounded?	<input type="checkbox"/>	<input type="checkbox"/>
Is there ample water supply?	<input type="checkbox"/>	<input type="checkbox"/>

# OPERATION INSTRUCTIONS

Have all flammable liquids or gases been removed from installation location?		
Is there adequate gas supply for the BTU rating of the burner?		
"Is incoming gas supply pressure between 6" - 14" water column inches or 1/2 PSIG?"		
Has the proper gas regulator been installed for pressure and volume?		
Is the machine properly vented to allow adequate air flow?		
Are the propane tanks large enough, according to rating to prevent freezing?		
Have gas lines been checked for gas leaks?		
Have gas lines been checked with local codes?		
Have all operators using this machine been instructed properly and have they read the manual?		
Has the machine been installed according to operator's manual instructions?		

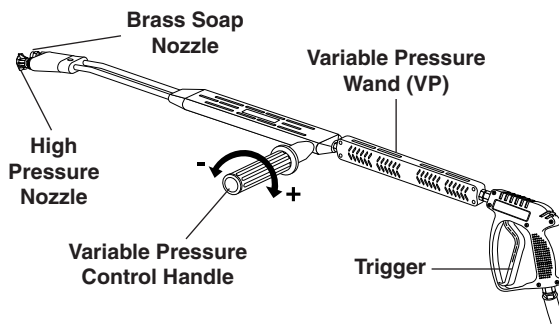

Selection of high or low pressure is accompanied by turning the handle. Note: High pressure nozzle must be inserted at end of wand to obtain high pressure. To apply soap read operator's manual.

## SHUT DOWN

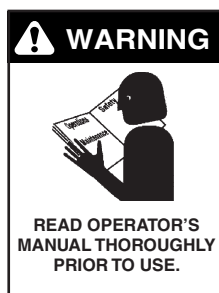

**1. STOP! Read operator's manual before operating this machine. Failure to read operation and warning instructions may result in personal injury or property damage.**

2. Turn all switches off.
3. Review installation instructions.
4. Connect water supply hose to the inlet connector and turn water on. Check for water leaks and tighten as needed.
5. Turn on the main gas supply and turn the gas valve control knob into the "ON" position .
6. Close the steam knob and detergent valve by turning clockwise and setting the temperature control knob between 200°- 225°F.
7. Before installing nozzle, turn on machine allowing water to run from the end of the wand until clear.
8. Attach the desired high pressure nozzle into the wand quick coupler by pulling the coupler collar back and inserting the nozzle. Secure nozzle by pushing the coupler collar forward.

9. Turn the pump switch on to start the machine. When spray gun is closed a time delay feature will turn the machine off.
10. For hot water, push the burner switch to the ON position and pull the trigger on the spray gun. Sparking begins, the pilot gas ignites and then the ignitor/sensor will turn the main burner on. The pump switch must be turned ON before the burner and remote detergent switches will turn on.
11. To apply detergent, open the detergent valve counterclockwise making sure that the detergent pick up tube is in the detergent solution and not sucking air. With optional remotes, the detergent switch needs to be turned to the OFF position before turning to the ON position to activate the detergent solenoid.
12. When steam is needed, turn the steam knob counterclockwise. Then turn the temperature adjustment knob to 275°F.
13. **TO STOP:** Turn the burner switch off and place the detergent pick-up tube into fresh water. Open the detergent valve and trigger spray gun allowing detergent lines to be flushed and the burner to cool. Otherwise, coil damage will result.
14. After water has cooled, turn pump switch to OFF position. If the machine is going to be off for an extended period of time, put the manual valve on the gas valve into the OFF position.
15. Turn the water off. Protect from freezing.

---

## GENERAL CLEANING TECHNIQUES

---

---

### CLEANING TECHNIQUES

---

Pre-rinse cleaning surface with fresh water. Place detergent suction tube directly into cleaning solution and apply to surface at low pressure (for best results, limit your work area to sections approximately 6 feet square and always apply detergent from bottom to top). Allow detergent to remain on surface 1-3 minutes. Do not allow detergent to dry on surface. If surface appears to be drying, simply wet down surface with fresh water. If needed, use brush to remove stubborn dirt. Rinse at high pressure from top to bottom in an even sweeping motion keeping the spray nozzle approximately 1 foot from cleaning surface. Use overlapping strokes as you clean and rinse any surface. For best surface cleaning action spray at a slight angle.

#### Recommendations:

- Before cleaning any surface, an inconspicuous area should be cleaned to test spray pattern and distance for maximum cleaning results.
- If painted surfaces are peeling or chipping, use extreme caution as pressure washer may remove the loose paint from the surface.
- Keep the spray nozzle a safe distance from the surface you plan to clean. High pressure wash a small area, then check the surface for damage. If no damage is found, continue to pressure washing.

#### **CAUTION - Never use:**

- Bleach, chlorine products and other corrosive chemicals
- Liquids containing solvents (i.e., paint thinner, gasoline, oils)
- Tri-sodium phosphate products
- Ammonia products
- Acid-based products

These chemicals will harm the machine and will damage the surface being cleaned.

---

### RINSING

---

It will take a few seconds for the detergent to clear. Apply safety latch to spray gun. Select and install desired high pressure nozzle. **NOTE:** You can also stop detergent from flowing by removing detergent siphon tube from bottle.

## MAINTENANCE

### PREVENTATIVE MAINTENANCE

1. Check to see that water pump is properly lubricated.
2. Follow Winterizing Procedures to prevent freeze damage to the pump and coils.
3. Always neutralize and flush detergent from system after use.
4. If water is known to be high in mineral content, use a water softener in your water system or de-scale as needed.
5. Do not allow acidic, caustic or abrasive fluids to be pumped through the system.
6. Always use high grade quality Landa cleaning products.
7. Never run pump dry for extended periods of time. Shut off timer will be set for two minutes.
8. Periodically delime coils per instructions.

It is advisable, periodically, to visually inspect the burner. Check air inlet to make sure it is not clogged or blocked. Wipe off any oil spills and keep this equipment **clean and dry**.

The areas around the Landa washer should be kept clean and free of combustible materials, gasoline and other flammable vapors and liquids.

The flow of combustion and ventilating air to the burner must not be blocked or obstructed in any manner.

**NOTE:** Pump damage may occur if ran in bypass longer than two minutes.

### MAINTENANCE AND SERVICE

#### Spray Nozzles

Each machine is equipped with one or more spray nozzles, depending on model. Different spray nozzles are calibrated for each machine depending on the flow and pressure of that particular model. Spray nozzles vary in bore size and angle of spray. Popular spray angles are 0°, 15°, 25°, 40°. When ordering, please specify size and angle of nozzle. Nozzle size for each machine is located on the serial plate.

#### Unloader Valves:

Unloader valves are preset and tested at the factory before shipping. Occasional adjustment of the unloader may be necessary to maintain correct pressure.

Call your Local Dealer for Assistance. Tampering with the factory setting may cause personal injury and or property damage, and will void the manufacturer's warranty.

#### Winterizing Procedure:

Damage due to freezing is not covered by warranty. Adhere to the following cold weather procedures whenever the washer must be stored or operated under freezing conditions.

During winter months, when temperatures drop below 32°F, protecting your machine against freezing is necessary. Siphoning a small amount of antifreeze into the system is recommended. This is done by pouring a 50:50 mix of antifreeze and water into the float tank and then siphoning 100% antifreeze through the detergent line with the pump on. If compressed air is available, an air fitting can be screwed into the float tank strainer fitting and by injecting compressed air, all water will be blown out of the system. The use of a draft diverter will prevent the wind chill factor from freezing the coil.

#### High Limit Hot Water Thermostat:

For safety, each machine is equipped with a high limit control switch. In the event the temperature of the water should exceed its operating temperature, the high limit control will turn the burner off until the water cools.

#### Pumps:

Use only SAE 20/40 weight non-detergent oil. Change oil after first 50 hours of use. Thereafter, change oil every three months or at 500 hour intervals. Oil level should be checked through use of the dipstick found on the top of the pump or by the red dot visible through the oil gauge window. Oil should be maintained at that level.

### HEATING COIL

#### Condensation from Heating Coil

When cold water is being pumped into the water heater coil, and the burner is on, condensation will form on the coil and drip down into the burner compartment, giving the appearance of a leaking coil, particularly on cold humid days.

#### To Check Water Heater Coil for Leaks:

With the main burner "OFF" start machine and allow it to run a few minutes. Look into the burner compartment with a drop light or flashlight. If no leaks are visible, then water dripping from coil is from condensation.

## MAINTENANCE & SERVICE

### Deliming Coil:

In alkaline water areas, lime deposits can accumulate rapidly inside the coil pipes. This growth is increased by the extreme heat build up in the coil. The best preventative for liming conditions is to use high quality cleaning detergents. In areas where alkaline water is an extreme problem, periodic use of Landa Deliming Powder will remove lime and other deposits before coil becomes plugged. (See Deliming Instructions for use of Landa Deliming Powder.)

Periodic coil deliming is recommended.

1. Fill a container with 4 gallons of water, then add 1 lb. of deliming powder. Mix thoroughly.
2. Remove nozzle from spray gun assembly and put spray gun into container.
3. Attach a short section (3-5 ft.) of garden hose to machine to siphon solution from an elevated container or add mixture to the float tank. Turn pump switch on allowing solution to be pumped through coil and back into the container. Solution should be allowed to circulate 2-4 hours.
4. After circulating solution flush entire system with fresh water. Reinstall nozzle in spray gun.

### GAS VALVE REGULATOR ADJUSTMENT

Adjustment of the built-in regulator isn't normally necessary, since it is preset at the factory. However, field adjustment may be accomplished as follows:

1. Attach manometer at pressure tap port.
2. Remove regulator adjustment screw cap.
3. With a small screwdriver, rotate the adjustment screw clockwise to increase or counterclockwise to decrease gas pressure.
4. Replace regulator adjustment screw cap (see Figure 5).

Figure 5

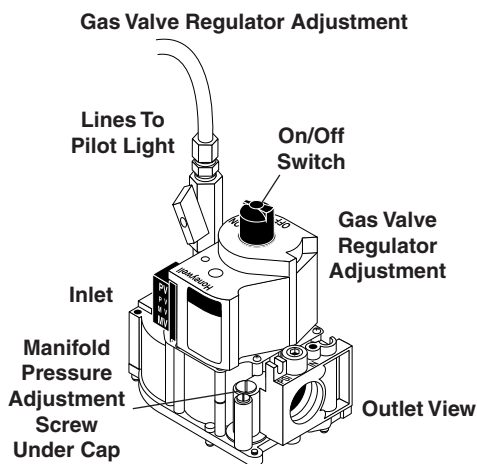

### Pressure Relief Valve

Each machine is equipped with a relief valve to relieve pressure in the system when higher than normal operating pressures are encountered. If operating pressure of machine is found to be normal and relief valve continues to leak, repair or replace the valve. **CAUTION: Relief valve can become obstructed by deposits and must be unscrewed at least once per year to allow discharge.**

## PROPANE GAS

### General Safety Precautions

Have a qualified gas service person assist in any gas burner installation or service. Few maintenance people or mechanics are knowledgeable in gas controls or related safety practices. Propane gas is heavier than air; unburned propane gas will gravitate to the floor rather than rise out of the stack. Hence, adequate floor space and good ventilation are especially important with propane systems.

### Gas Pressure Requirements

All propane fired machines operate on vapor propane fuel only. They are designed to operate at a pressure of 11 w.c.i. (between 1/3 and 1/2 of one psi), and are often operated at even higher pressures when extra heat is needed.

Exterior regulators are needed to control the system. Propane bottles are not included with the machine. A high pressure regulator should be installed on the propane bottle and a low pressure regulator attached to the pressure washer.

### Propane Cylinder Capacity

An important consideration with propane systems is the capacity of the supply cylinder relative to the needs of the burner. The burner operates on propane as a vapor gas. As gas is used from the propane cylinder, the liquid in the cylinder boils to maintain vapor gas pressure. This boiling process cools the liquid, and in a heavy, continuous-demand situation, the liquid temperature can fall to the point at which it cannot provide vapor gas as rapidly as is needed. In this case, it may be necessary to warm the propane cylinder by directing a warm spray, not over 120°F, on the cold cylinder or by manifolding two propane bottles together to increase total vaporization capacity. It is recommended that a minimum 100 lb. vapor propane bottle be used on the machine, depending on the length of running time desired.

## BURNER FEATURES

### Operated Automatic Valve

This machine is equipped with an Intermittent Pilot Ignition System. This system is designed to eliminate the need for a constant burning pilot. Lighting of the pilot is accomplished through electronic spark ignition each time the burner and flow switch call for heat. The pilot is not burning when there is no call for heat. Do not attempt to light the appliance manually as a burn injury or electrical shock may result. The pilot light will remain on and the main gas valve is turned off when the spray gun is closed.

### Care of Main Burner

Due to condensation from heater coils dripping down on the burners, scale build-up may occur in the burner jet orifices.

#### 1. TO REMOVE BURNER MANIFOLD FROM WATER HEATER COIL:

Turn off the gas to the main burner by turning the knob to the "OFF" position on the gas valve and the main gas supply.

Disconnect the pilot and ignition lines from the gas valve. Disconnect union in main burner line below thermostat. Slide burner manifold out through shell opening.

#### 2. TO CLEAN BURNER JETS:

Select proper size drill for type gas involved. Use pin vise to hold drill and ream out each jet orifice.

**CAUTION: Do not ream out orifices to a larger size.**

If the water heater will be exposed to freezing weather, an anti-freeze solution should be circulated through the coil by whatever means are available for the particular system the water heater is used on.

### To Adjust Pressure Regulator

Adjustment of the pressure regulator is not normally necessary since it is preset at the factory. However, field adjustment may be accomplished as follows:

1. Manometer attachment may be accomplished at the pressure tap plug.
2. Remove regulator adjustment screw cap (see Figure 5, page 14).
3. With small screwdriver, rotate adjustment screw clockwise to increase, or counterclockwise to decrease pressure.
4. Replace regulator adjustment screw cap.

## PREVENTATIVE MAINTENANCE

This pressure washer was produced with the best available materials and quality craftsmanship. However, you as the owner have certain responsibilities for the correct care of the equipment. Attention to regular preventative maintenance procedures will assist in preserving the performance of your equipment. Contact your Landa dealer for maintenance. Regular preventative maintenance will add many hours to the life of your pressure washer. Perform maintenance more often under severe conditions.

MAINTENANCE SCHEDULE		
Pump Oil	Inspect	Oil level daily
	Change	After first 50 hours, then every 500 hours or annually
Check and Tighten Belts		Every 3 months
Remove Burner Soot		Annually
Burner Adjustment/Cleaning		Annually
Clean Burner Nozzles		Annually
Descale Coil		Annually (More often if required)
Replace High Pressure Nozzle		Every 6 months
Replace Quick Couplers		Annually
Clean Water Screen/Filter		Weekly
Replace HP Hose		Annually (If there are any signs of wear)
Grease Motor		Every 10,000 hours

### OIL CHANGE RECORD

Date Oil Changed Month/Day/Year	Estimated Operating Hours Since Last Oil Change

## TROUBLESHOOTING - BURNER

PROBLEM	POSSIBLE CAUSE	SOLUTION
<b>FLOW &amp; BURNER SWITCH ON; NO SPARK, NO PILOT GAS</b>	A. No main power	With power switch on, open trigger on spray gun and set your test meter to the 24 volt scale. Probe terminals 24V and 24V(GND). If you do not read 24 volts, the problem is not the ignition system. Perform normal system checks of main power, transformer, thermostat and the limit control. If you do read 24 volts at TH and GND, the problem is in the ignition system. Check for loose or defective wiring. If wiring is good, replace the ignition control unit.
	B. Faulty transformer	
	C. Faulty burner & flow switch	
	D. Faulty ignition control unit	
<b>HAVE SPARK, NO PILOT GAS FLOW</b>	Main gas supply turned off	Set test meter to 24 volt scale.
		1. Be sure main gas valve (gas cock or selector arm) is turned on.
		2. With gas on and system sparking, probe terminals PV and 24V(GND). If pilot gas does not flow with 24 volts at these terminals, replace gas valve.
		3. Probe terminals PV and MV/PV. If 24 volts not present, replace ignition control box.
<b>HAVE PILOT GAS, NO SPARK</b>	A. Defective ignitor/sensor and or its wiring	Set test meter to ohm scale.
		1. Disconnect the wire from the IGN terminal on the ignition control unit.
	B. Faulty ignition control unit	2. Touch one meter probe to the tip of the ignitor/sensor rod in the pilot. Touch the other probe to the quick connect at the other end of ignitor/sensor wire.
		3. If you have continuity from the tip of the ignitor/sensor rod to the connector and no spark, replace the ignition control unit.
		4. If you do not have continuity through wire and the ignitor/sensor, check for a loose wire connection in the wire. Repair as needed.
		5. Check to see if spark shorts to burner ring through a cut in the ignitor wire.

## TROUBLESHOOTING - BURNER

PROBLEM	POSSIBLE CAUSE	SOLUTION
<b>HAVE PILOT FLAME, MAIN BURNER WILL NOT TURN ON</b>	Faulty main valve coil in the gas valve	Set test meter to 24 volt scale.
	Faulty ignitor/sensor and/or its wiring	With pilot flame on ignitor/sensor, probe terminals MV and MV/PV on the ignition control unit. If you read 24 volts here, but not at the gas valve, there is a loose wiring connection. Repair or replace as needed.
	Ground wire not attached to machine chassis	If you do read 24 volts at MV and MV/PV and the pilot flame is impinging on the ignitor/sensor rod, the problems may be:
	Faulty ignition control unit	a. Faulty ignitor/sensor and/or its wiring.
		b. Faulty ignition control unit.
		Set test meter to the ohm scale. Turn burner switch off.
Check continuity through the green ground wire and its connections.		
	Reconnect the ignitor/sensor wire and the ground wire.	
	Turn burner switch on. With the pilot burning and the flame on the ignitor/sensor rod, the main burner should turn on. If it does not, replace the ignition control unit.	
<b>SHORT-CYCLING OF MAIN BURNER. MAIN BURNER TURNS OFF BEFORE THE BURNER SWITCH OR FLOW SWITCH IS TURNED OFF</b>	Draft condition pulls flame away from ignitor/sensor rod.	Check the thermostat by bypassing at terminals P1 & 1.
		Set thermostat high. With main burner on, observe the pilot flame impingement on the ignitor/sensor.
	Faulty thermostat or water temperature is too high	If pilot flame is small and draft condition pulls flame from ignitor sensor rod, the burner will turn off and then on again. a. Adjust pilot flame higher or clean pilot oriface. b. Bend ignitor/sensor rod closer to pilot flame.
		If flame impingement on the ignitor/sensor is stable and the system short-cycles, check the limit switch.
	Set test meter to 110 volt scale; a. When the system cycles off, probe the switch terminals of the limit switch. b. If you read 24V accross the switch terminals the limit switch is open. Replace the limit switch.	
	A pilot flame set too high will also cause burner to short cycle. Pilot flame lifts over ignitor/sensor.	

## TROUBLESHOOTING

PROBLEM	POSSIBLE CAUSE	SOLUTION
<b>LOW OPERATING PRESSURE</b>	Faulty pressure gauge	Install new gauge.
	Insufficient water supply	Use larger garden hose; clean filter washer at water inlet.
	Old, worn or incorrect spray nozzle	Match nozzle number to machine and/or replace with new nozzle.
	Belt slippage	Tighten or replace; use correct belt.
	Plumbing or hose leak	Check plumbing.
	Faulty or misadjusted unloader valve (where applicable)	Adjust unloader for proper pressure. Install repair kit when needed.
	Worn packing in pump	Install new packing kit.
	Fouled or dirty inlet or discharge valves in pump	Clean inlet and discharge valves.
	Worn inlet or discharge valves	Replace with valve kit.
	Obstruction in spray nozzle	Remove obstruction.
	Leaking pressure control valve (where applicable)	Rebuild or replace as needed.
	Detergent metering valve left open sucking air, or faulty metering valve	Close and/or replace metering valve.
	Slow motor RPM	Check incoming voltage.
<b>LOW WATER TEMPERATURE</b>	Improper size of gas lines	See pages 7-8 for sizing of gas lines.
	Low gas pressure	Increase gas pressure to machine.
	Improper pressure regulator	Specify BTU, building gas pressure and 11 w.c.i. to machine for correct sizing of regulator.
	Low gas valve pressure	Increase gas pressure as described on page 14.
	Soot buildup on coils not allowing heat transfer	Clean coils.
	Improper burner nozzle	See exploded view parts list.

## TROUBLESHOOTING

PROBLEM	POSSIBLE CAUSE	SOLUTION
<b>WATER TEMPERATURE TOO HOT</b>	Incoming water to machine warm or hot	Lower incoming water temperature.
	Gas pressure too high	Call local gas company.
	Detergent line sucking air	Tighten all clamps. Check detergent lines for holes.
	Defective high limit switch	Replace.
	Incorrect burner nozzle size	See exploded view parts list.
	Insufficient water supplied	Check water G.P.M. to machine.
	Restricted water flow	Check nozzle for obstruction, proper size.
<b>DETERGENT NOT DRAWING</b>	Air leak	Tighten all clamps. Check detergent lines for holes.
	Detergent metering valve packing not tight or packing worn	Tighten nut. Replace valve or packing.
	Filter screen on detergent suction hose plugged	Clean or replace.
	Dried up detergent plugging metering valve	Disassemble and clean thoroughly.
	High viscosity of detergent	Dilute detergent to specifications.
	Restriction behind float tank screen removed	Install restriction.
	Hole in detergent line(s)	Repair hole.
	Strainer basket plugged	Remove and clean.
	Connections on selector valve loose	Put teflon tape on all pipe connections.
	Detergent solenoid not opening (where applicable)	Check flow switch, replace detergent solenoid.
	<b>PUMP RUNNING NORMALLY BUT PRESSURE LOW ON INSTALLATION</b>	Pump sucking air
Valves sticking		Check and clean or replace if necessary.
Unloader valve seat faulty		Check and replace if necessary.
Nozzle incorrectly sized		Check and replace if necessary (see serial plate for proper size).
Worn piston packing		Check and replace if necessary.

## TROUBLESHOOTING

PROBLEM	POSSIBLE CAUSE	SOLUTION
<b>FLUCTUATING PRESSURE</b>	Valves worn	Check and replace if necessary.
	Blockage in valve	Check and replace if necessary.
	Pump sucking air	Check water supply and air seepage at joints in suction line.
	Worn piston packing	Check and replace if necessary.
<b>PUMP NOISY</b>	Air in suction line	Check water supply and connections on suction line.
	Broken or weak inlet or discharge valve springs	Check and replace if necessary.
	Excessive matter in valves	Check and clean if necessary.
	Worn bearings	Check and replace if necessary.
<b>PRESENCE OF WATER IN OIL</b>	Oil seal worn	Check and replace if necessary.
	High humidity in air	Check and change oil twice as often.
<b>WATER DRIPPING FROM UNDER PUMP</b>	Piston packing worn	Check and replace if necessary.
	O-ring plunger retainer worn	Check and replace if necessary.
<b>OIL DRIPPING</b>	Oil seal worn	Check and replace if necessary.
<b>EXCESSIVE VIBRATION IN DELIVERY LINE</b>	Irregular functioning of the valves	Check and replace if necessary.
<b>RELIEF VALVE LEAKS WATER</b>	Relief valves defective	Replace or repair.

# EXPLODED VIEW - 4-2000, 4-3000

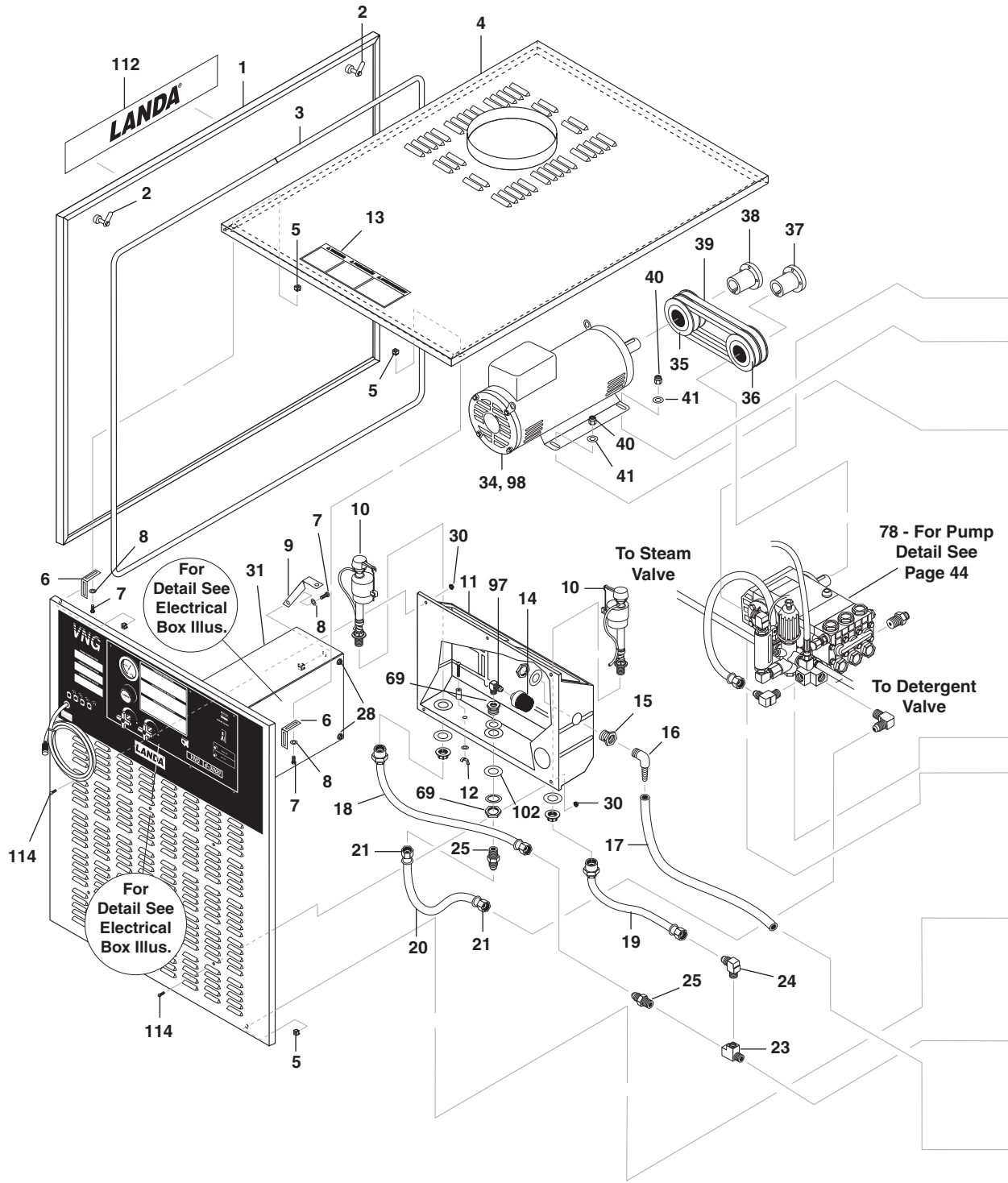

# EXPLODED VIEW - 4-2000, 4-3000

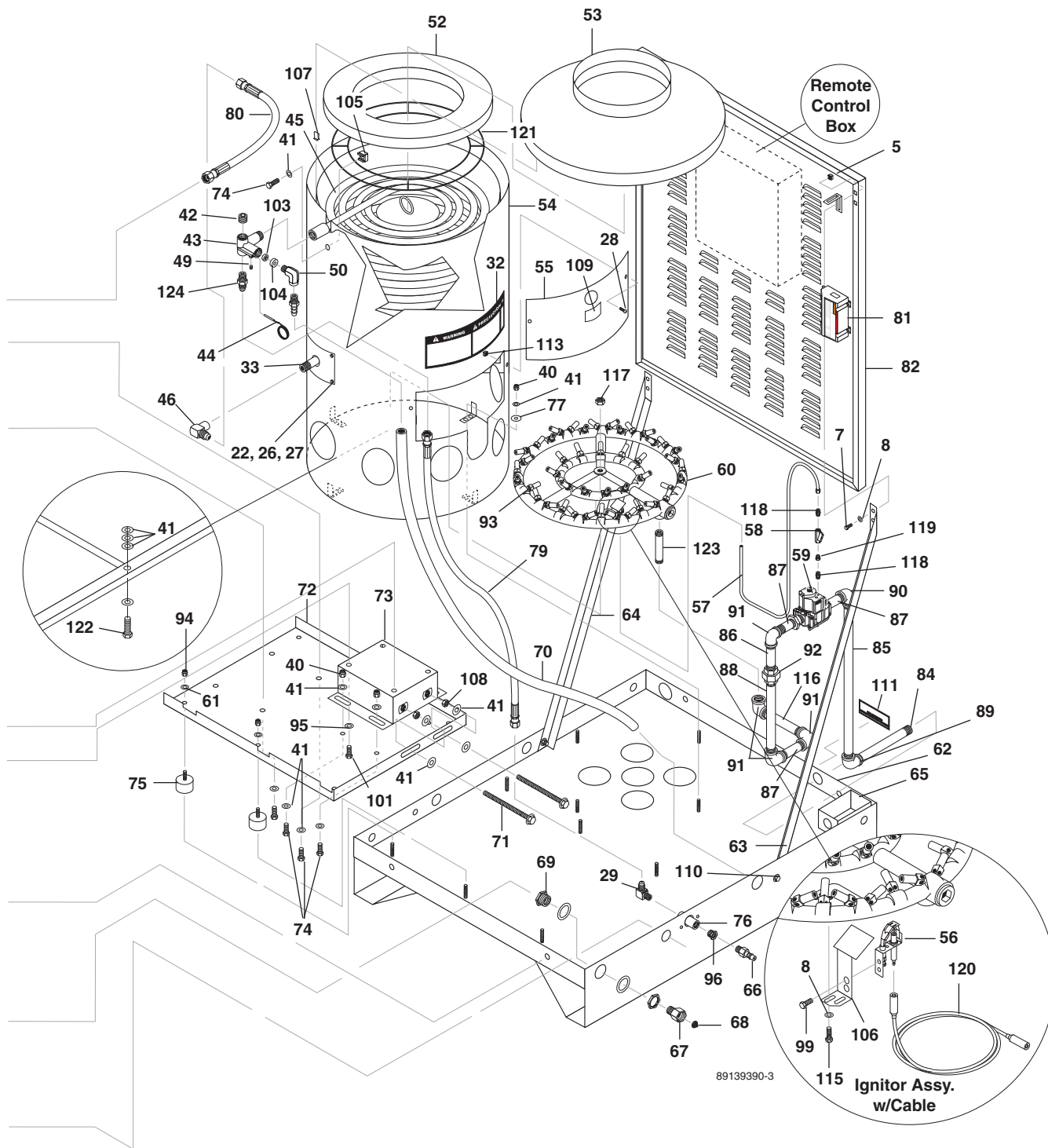

## 4-2000, 4-3000 EXPLODED VIEW PARTS LIST

ITEM	PART NO.	DESCRIPTION	QTY
1	8.912-539.0	Panel, Side VNG-S	2
2	8.719-066.0	Latch, Vise Action	4
3	9.802-072.0	Trim, w/Sponge	26.5 ft
4	8.912-536.0	Panel, Top VNG-S	1
5	9.802-793.0	Nut, Cage, 1/4" x 16 Gauge	26
6	8.912-528.0	L-Bracket, VNG	4
7	9.802-700.0	Bolt, 1/4" x 3/4" NC HH	21
8	9.802-802.0	Washer, 1/4" Flat SAE	23
9	8.912-527.0	Brace, VNG Electrical Box	1
10	9.802-185.0	Valve, Float Tank, Vertical	2
11	9.802-084.0	Tank, Plastic, Universal Float	1
12	9.802-106.0	Plug, Float Tank	1
13	9.800-033.0	Label, Warning, Hot Water	1
14	8.707-061.0	Strainer, 1/2" Basket	1
15	9.802-052.0	Bulkhead, 3/4" Polypro	1
16	9.802-050.0	Adapter, 3/4" x 3/4" MT x Insert, 90°	1
17	9.802-261.0	Hose, 3/4" Push-on	2.5 ft.
18	9.802-257.0	Inlet Hose, 30", Water Supply	1
19	8.711-775.0	Inlet Hose, 13", Water Supply	1
20	9.802-259.0	Hose, 1/2" Push-on	1.5 ft.
21	9.802-151.0	Swivel, 1/2" JIC Fem, Push-on	2
22	9.802-798.0	Screw, Tek, #10 x 1/2"	4
23	8.706-860.0	Tee, 1/2" Street	1
24	9.802-131.0	Elbow, 1/2" JIC x 1/2" Pipe 90°	1
25	9.802-128.0	Nipple, 1/2" JIC x 1/2"	2
26	8.933-009.0	Gasket, Burner Plate	1
27	9.803-132.0	Plate, Insulation Retainer	1
28	9.802-764.0	Screw, 10/32" x 3/4" HEX	6
29	9.802-040.0	Elbow, 1/2" JIC x 1/2" 90°	1
30	9.802-695.0	Nut, 10/32" KEPS	6
31	9.802-969.0	Box, Electrical, VNG	1
32	9.800-031.0	Label, Pilot Light Warning	1
33	9.802-014.0	Nipple, 1/2" x 3" Galv. Pipe	1
34		Motor, See Specifications Pages	
35		Pulley, Motor, See Specifications Pages	
36		Pulley, Pump, See Specifications Pages	
37		Bushing, Pump, See Specifications Pages	
38		Bushing, Motor, See Specifications Pages	
39		Belt, See Specifications Pages	
40	8.725-395.0	Nut, 3/8" ESNA	12
41	8.725-394.0	Washer, 3/8" Flat, SAE	36
42	8.706-248.0	Plug, 3/8", Counter Sunk	1
43	9.149-003.0	Discharge Manifold	1
44	8.750-095.0	Thermostat, 302°	1
	8.750-096.0	(Knob)	1

ITEM	PART NO.	DESCRIPTION	QTY
45	9.803-135.0	Coil, Dura 20" Dia, Sch 80	1
46	9.802-043.0	Elbow, 1/2", 90°, Female, JIC	1
47	9.802-159.0	Connector, 1/4" Tube x 1/4" MPT	1
48	8.918-421.0	Hose, 1/4" x 36" Gauge	1
49	9.196-012.0	Screw 10-24 x 1/4"	1
50	8.706-207.0	Elbow, 3/8" STR, 90° Steel25	1
51	8.707-019.0	Hose Barb, 1/2" Barb x 3/8" MPT, Push-On	1
52	8.930-140.0	Insulation, Top Head, 20"	1
53	9.802-976.0	Top, Burner Wrap, 20"	1
54	8.917-568.0	Wrap, Outer Assy, 20"	1
55	9.802-975.0	Cover, Burner Access, 20" Coil	1
56	9.803-610.0	Pilot, Natural Gas Pilot	1
57	9.802-911.0	Tubing, Aluminum	36"
58	9.802-178.0	Valve, 1/4" Jomar, T-91LP, Ball	1
59	9.803-616.0	Valve, Gas VR8304	1
	9.803-618.0	▲ LPG Regulator Kit (LP Gas Valve Conversion Kit)	1
60	8.718-055.0	Burner Ring Assy, X44, w /#54 Jets	1
	8.718-060.0	Burner Ring Assy, X44, w /#63 Jets (LP Option)	1
61	8.718-980.0	Washer, 5/16" Flat, SAE	6
62	8.912-534.0	Base, VNG, Small	1
63	8.912-541.0	Brace, Left Side, VNG-S	1
64	8.912-540.0	Brace, Right Side VNG-S	1
65	9.802-484.0	Box, Junction 3 Hole, 3/4"	1
	9.802-425.0	▲ Cord, Service 8/3 (4-3A,G)	6 ft.
	9.802-436.0	▲ Cord, Service 10/3 (4-2A,G)	6 ft.
	9.802-437.0	▲ Cord, Service 10/4 (4-3B, C, H)	6 ft.
	9.802-429.0	▲ Cord, Service, 12/4 (4-2B, C, F, H; )	6 ft.
	9.800-040.0	▲ Label, Ground	1
65	8.718-945.0	▲ Screw, #14 x 3/4", Tek	2
	9.802-520.0	▲ Strain Relief, 3/4"	1
	9.802-483.0	▲ Cover, 2" x 4", Metal	1
66	9.802-171.0	Nipple, 3/4" x 3/8", NPT ST Male	1
67	9.802-146.0	Swivel, 1/2" MP x 3/4" GHF	1
68	8.707-055.0	Strainer, Inlet, Garden Hose	1
69	8.707-000.0	Connector, 1/2", Anchor	1

## 4-2000, 4-3000 EXPLODED VIEW PARTS LIST

ITEM	PART NO.	DESCRIPTION	QTY
70	9.802-259.0	Hose, 1/2", Push-On	4 ft.
71	9.802-735.0	Bolt, 3/8" x 5-1/2" NC HH Tap	2
72	9.803-130.0	Platform, Motor 3/16"	1
73	9.803-131.0	Rail, Pump, General Combo	1
74	9.802-720.0	Bolt, 3/8" x 1" NC HH	16
75	9.803-532.0	Isolator, 5/16" Fem x Fem	6
76	8.912-530.0	Discharge Assy	1
	9.804-003.0	Screw, 1/4" x 3/4"	2
	9.802-773.0	Nut, 1/4" ESNA	2
77	9.802-811.0	Washer, 5/16" Fender	4
78	Pump, See Specifications Pages		
79	8.918-211.0	Hose, 3/8" x 40", 2 Wire	1
80	8.918-424.0	Hose, 3/8" x 25", 2 Wire	1
81	9.803-613.0	Ignition, Electronic Control	1
	9.802-759.0	▲ Screw, 10/32" x 1/2"	4
	9.802-695.0	▲ Nut, 10/32" Keps	4
82	8.912-538.0	Panel, Burner End	1
83	8.716-269.0	Box, Metal, Junction, 12" x 12" x 4" Remote	1
84	8.706-022.0	Nipple, 1" x 6" Black Pipe	1
85	8.719-959.0	Pipe, 1" NPT x 18" Black	1
86	9.802-018.0	Nipple, 3/4" x 3" Black Pipe	1
87	9.802-019.0	Nipple, 3/4" x 2" Pipe	3
88	9.802-020.0	Nipple, 3/4" x 6" Black, Pipe	1
89	9.802-026.0	Elbow, 1" Black Pipe, 90°	1
90	9.802-028.0	Elbow, 1" x 3/4" Reducing, 90°	1
91	9.802-027.0	Elbow, 3/4" Black, 90°	4
92	9.802-049.0	Union, 3/4" Black Pipe	1
93	8.710-215.0	Gas Jet, NG, #52	44
	8.717-377.0	Gas Jet, LP, #63	44
94	9.802-776.0	Nut, 5/16" ESNA	6
95	9.804-057.0	Washer	4
96	8.706-294.0	Bushing, 1/2" x 3/8" Steel	1
97	9.802-131.0	Elbow, 1/2" Street, Brass	1
98	9.802-425.0	▲ Cord, Service, SO, 8/3 Coleman (4-3A, G)	4.25 ft.
	9.802-436.0	▲ Cord, Service, SEO, 10/3, Coleman (4-2A, G)	4.25 ft.
	9.802-437.0	▲ Cord, Service, SO, 10/4 Coleman (4-3B, C, H)	4.25 ft.
	9.802-429.0	▲ Cord, Service, SEO, 12/4 Coleman (4-2B,C,F,H;)	4.25 ft.

ITEM	PART NO.	DESCRIPTION	QTY
	9.802-520.0	Strain Relief, 3/4" (4-2)	1
	9.802-522.0	Strain Relief, 1" (4-3)	1
99	9.802-772.0	Screw, 10/32" x 1/4" Hex	2
100	9.802-016.0	Bushing, 1" x 3/4"	1
101	9.804-058.0	Bolt, Pump Mounting	4
102	8.719-039.0	Washer, 1-3/16" x 2-1/4"	1
103	8.725-944.0	Disk Rupture 8000#	1
104	9.184-030.0	Spacer, Rupture Disk	1
105	9.802-792.0	Nut, 3/8" x 12 Gauge, Cage	8
106	8.719-957.0	Splash Guard, Pilot Light	1
107	9.802-825.0	Clips, Retaining	4
108	9.802-789.0	Nut, 3/8" Hex, NC	2
109	9.800-028.0	Label, Pilot Light	1
110	9.802-767.0	Screw, 3/8" x 3/4" HH NC, Whiz	2
111	8.932-963.0	Label, Liquid Propane	1
	8.932-964.0	Label, Natural Gas	1
112	8.900-802.0	Label, VNG Landa Stripe	2
113	9.802-791.0	Nut, 10/32 x 16 Gauge, Cage	2
114	9.802-759.0	Screw, 10/32" x 1/2" Black	2
115	8.718-582.0	Bolt 1/4" x 1/2" NC, HH	2
116	8.706-109.0	Nipple, 3/4" x 7", Black Pipe	1
117	9.802-781.0	Nut, 3/8" NC, Whiz -Loc	1
118	9.803-563.0	Connector, 1/4" Tube x 1/8" MPT	1
119	8.706-910.0	Bushing, 1/4" x 1/8" Bushing	1
120	9.803-562.0	Cable, Ignition, 48"	1
121	8.719-940.0	Ring, Insulation Retainer	1
122	9.802-769.0	Bolt, 3/8" x 1 3/4" NC, Whiz -Loc	1
123	8.706-087.0	Nipple, 3/4" x 4" Black Pipe	1
124	9.802-127.	Nipple, 1/2" x JIC x 3/8" MPT	1

▲ Not Shown

# EXPLODED VIEW - 6-3000, 8-3000, 10-2000

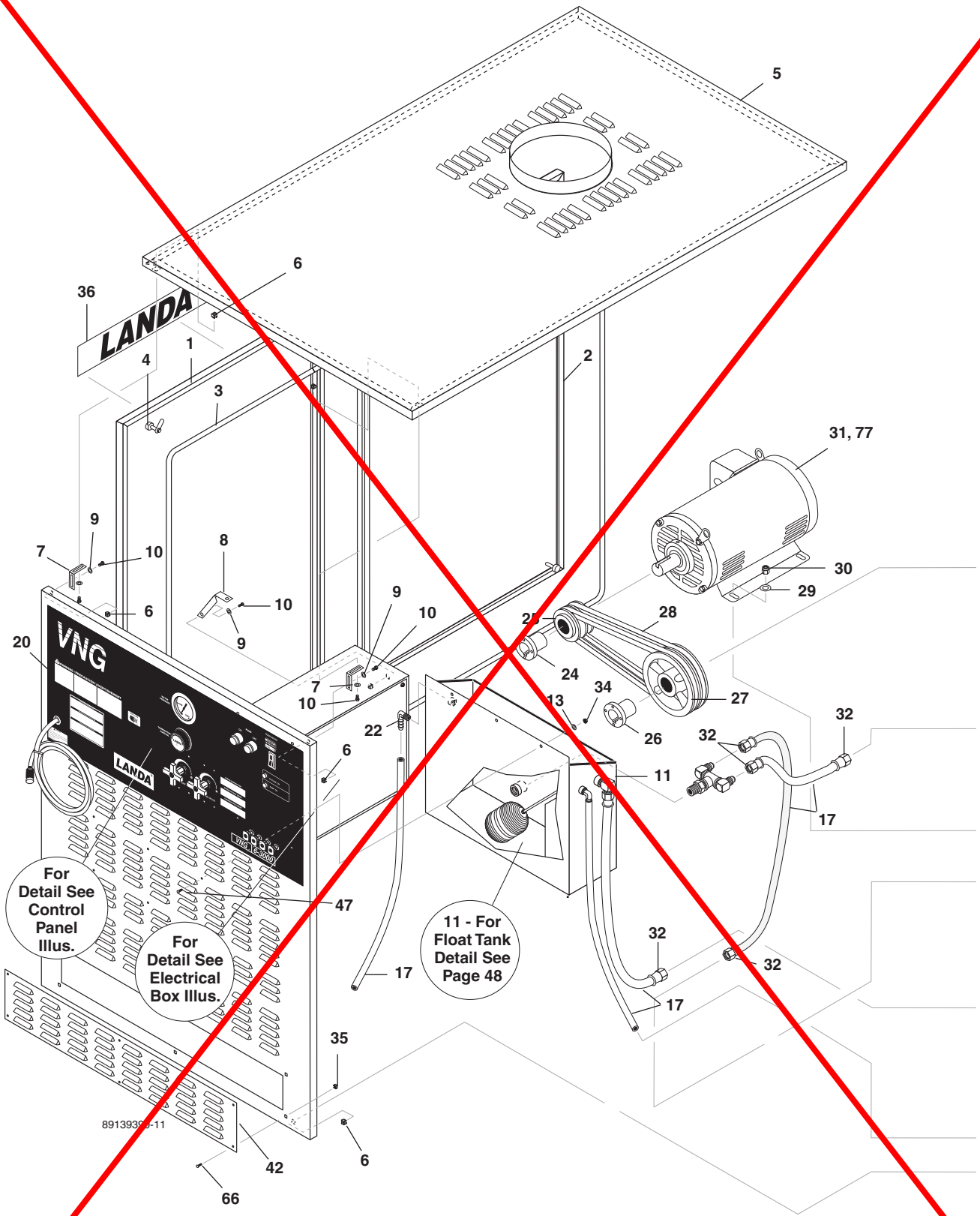

# EXPLODED VIEW - 6-3000, 8-3000, 10-2000

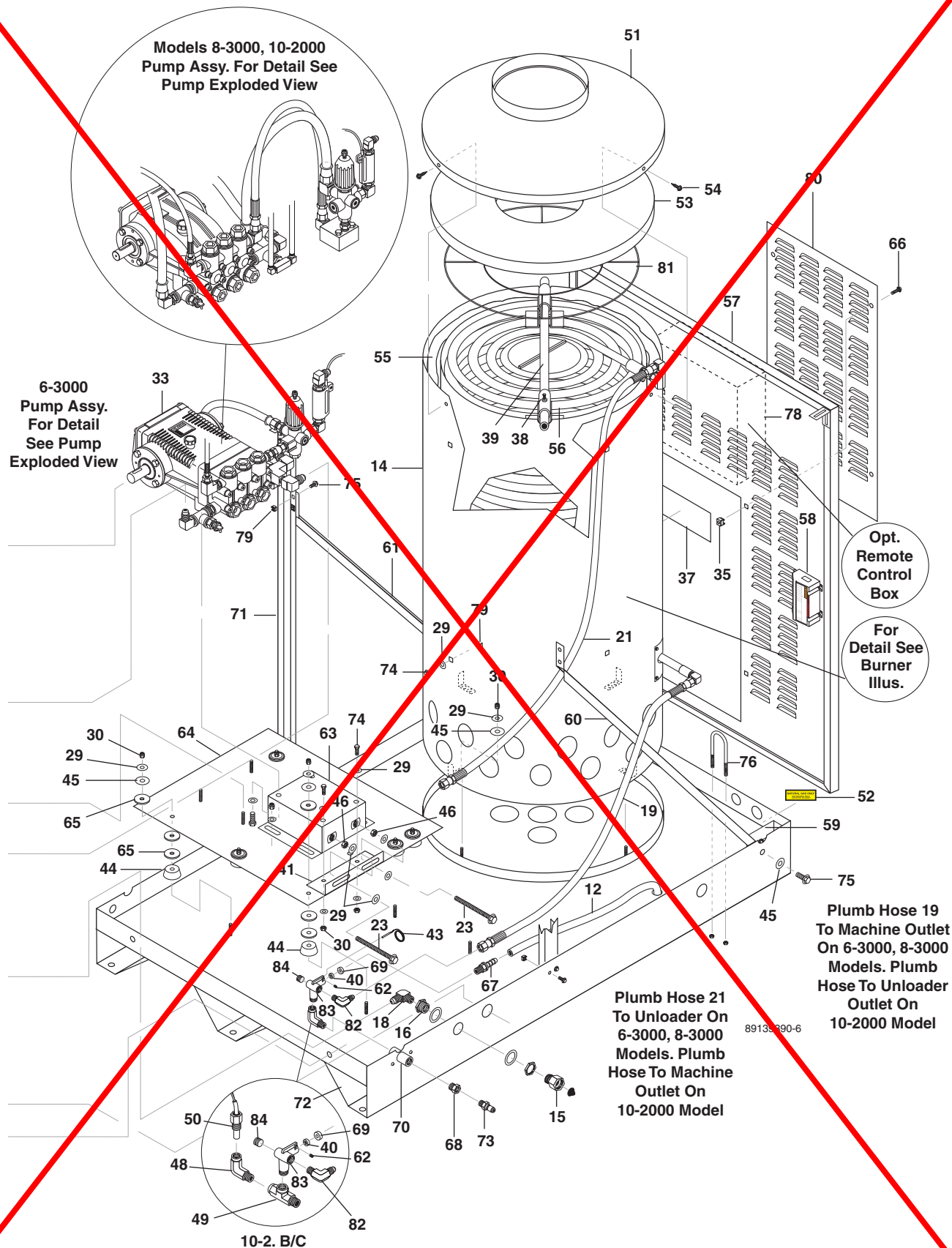

## 6-3000, 8-3000, 10-2000 EXPLODED VIEW PARTS LIST

ITEM	PART NO.	DESCRIPTION	QTY	ITEM	PART NO.	DESCRIPTION	QTY
1	8.912-517.0	Panel, Side, Small, VNG-L	2	40	8.725-944.0	Disk, Rupture 8000 #	1
2	8.912-515.0	Panel, Side, Large, VNG-L	2	41	8.912-381.0	Retainer, Pump Take-Up	1
3	9.802-072.0	Trim, 1/16", w/Sponge	55 ft.	42	8.912-512.0	Panel, Pully Access	1
4	8.713-066.0	Latch, Vise Action	8	43	8.950-094.0	Thermostat, Adjustable, 302°F	1
5	8.912-510.0	Panel, Top, VNG-L	1	44	9.802-066.0	Pad, Foot, Soft Rubber	7
6	9.802-793.0	Nut, Cage, 1/4" x 16 Gauge	26	45	9.802-811.0	Washer, 3/8" x 1-1/2"	13
7	8.912-528.0	L-Bracket, VNG	8	46	9.802-789.0	Nut, 3/8" Hex, NC	2
8	8.912-527.0	Brace, VNG, Electrical Box	1	47	9.802-771.0	Screw, 10/32" x 3/4"	3
9	9.802-802.0	Washer, 1/4", Flat, SAE	22	48	8.706-208.0	Elbow, 1/2" Street	1
10	9.802-700.0	Bolt, 1/4" x 3/4"	22	49	8.706-236.0	Tee, 1/2" Street 10-2B, 10-2C	2
11	8.903-590.0	Float Tank Assy	1	50	8.712-187.0	Switch, Snap, 275° Hi-Limit 10-2B, 10-2C	1
12	9.802-259.0	Hose, 1/2" Push-on	44"	51	8.912-546.0	Top, Burner Wrap, 30" ENG/VNG Large	1
13	9.804-082.0	Washer, 1/4" Black	3	52	8.932-964.0	Label, Natural Gas	1
14	8.912-553.0	Module, Wrap, Outer, Large	1		8.932-963.0	Label, Liquid Propane	1
15	9.802-146.0	Swivel, 1/2" MP x 3/4" GHF	1	53	8.730-141.0	Insulation, Top Head 30"	1
16	8.707-000.0	Connector, 1/2" Anchor	1	54	9.802-799.0	Screw, Tek #14 x 1"	3
17	9.802-261.0	Hose, 3/4" Push-On	15.75 ft.	55	8.717-435.0	Insulation Blanket, Die-Cut	1
18	9.802-132.0	Elbow, 3/4" JIC x 1/2", 90°	1	56	8.912-248.0	Coil, 25" Dia. VNG-L	1
19	8.918-229.0	Hose, 1/2" x 54", 2 Wire Pressure Loop (6-3, 8-3)	1	57	8.912-513.0	Panel, Burner End, VNG-L	1
	8.918-227.0	Hose, 1/2" x 36", 2 Wire, Pressure Loop (10-2)	1	58	9.803-613.0	Ignition, Control Electric	1
20	9.800-033.0	Label, Warning, Hot Water	1		9.802-759.0	▲ Screw, 10/32" x 1/2"	4
21	8.918-229.0	Hose, 1/2" x 54", 2 Wire Pressure Loop (6-3, 8-3)	1		9.802-695.0	▲ Screw, 10/32" Keps	4
	8.918-230.0	Hose, 1/2" x 70", 2 Wire Pressure Loop (10-2)	1	59	8.715-339.0	Box Junction (6-3B, 8-3B, H; 10-2B)	1
22	9.802-050.0	Adapter, 3/4" x 3/4" MT Insert, 90°	2		9.802-484.0	Box, Junction, 3 Hole (6-3C, 8-3C, 10-2C,)	1
23	9.802-735.0	Bolt, 3/8" x 5-1/2" NC, RH	2		9.802-520.0	▲ Strain Relief, 3/4" (6-3C, 8-3C, 10-2C,)	1
24		Motor Bushing, See Specifications Pages			9.802-522.0	▲ Strain Relief, 1" (6-3B, 8-3C, 10-2B)	1
25		Motor Pulley, See Specifications Pages			9.803-975.0	▲ Strain Relief, CG 100-1050, 1" Blk (4/4 COR) 8-3B/H, 10-2B	1
26		Bushing, See Specifications Pages			8.718-945.0	▲ Screw, #14 x 3/4" Tex	2
27		Pump Pulley, See Specifications Pages			9.800-040.0	▲ Label, Ground	1
28		Pump Belt, See Specifications Pages			9.802-437.0	▲ Cord, Service, 10/4 (6-3C; 8-3C; 10-2C)	8.5 ft.
29	8.725-394.0	Washer, 3/8" Flat (6-3) (8-3, 10-2)	35 37	59	9.802-483.0	▲ Cover, 2" x 4", Metal	1
30	8.725-395.0	Nut, 3/8" ESNA, NC (6-3) (8-3, 10-2)	21 23		9.803-992.0	▲ Cord, Service, SO, 4/4 (8-3B, H; 10-2B)	8.5 ft.
31		Motor, See Specifications Pages			8.715-933.0	▲ Cord, Service, SO, 6/4 (6-3B,)	8.5 ft.
32	9.802-152.0	Swivel, 3/4" Female, Push-On	6	60	8.912-523.0	Brace, Right Side, VNG-L	1
33		Pump, See Specifications Pages		61	8.912-521.0	Brace, Left Side, VNG-L	1
34	9.802-695.0	Nut, 10/32" Keps	3	62	9.196-012.0	Screw, 10-24 x 1/4"	1
35	9.802-791.0	Nut, Cage, 10/32" x 16 Gauge	12				
36	8.900-802.0	Label, Landa Logo	2				
37	9.800-031.0	Label, Pilot Warning Light	1				
38	8.719-515.0	Bolt, 3/8" x 1-1/4" NC, Black	1				
39	8.912-249.0	Crosshanger, 1", SCH 80	1				

## 6-3000, 8-3000, 10-2000 EXPLODED VIEW PARTS LIST

ITEM	PART NO.	DESCRIPTION	QTY
63	9.803-131.0	Rail, Pump (6-3)	1
	8.912-215.0	Rail, Pump (8-3,10-2)	1
64	8.912-533.0	Power Platform, VNG-L	1
65	9.802-067.0	Bumper Pad, Engine	21
66	9.802-759.0	Screw, 10/32" x 1/2"	12
67	8.707-381.0	Push-on, 1/2" Barb x 3/8" MPT	1
68	8.706-294.0	Bushing, 1/2" x 3/8", Steel	1
69	9.184-030.0	Spacer, Rupture Disk	1
70	8.912-530.0	Coupling, Discharge, VHC	1
	9.804-003.0	▲ Screw, 1/4" x 3/4"	2
	9.802-773.0	▲ Nut, 1/4" ESNA	2
71	8.912-519.0	Vertical Brace, VNG-L	2
72	8.912-509.0	Base, VNG-L	1
73	9.802-171.0	Nipple, 3/8" x 3/8" NPT ST, Male	1
74	9.802-720.0	Bolt, 3/8" x 1", NC HH	10
75	9.802-767.0	Screw, 3/8" x 3/4", 12 Gauge	14
76	9.802-718.0	U-Bolt, 5/16" x 1" Pipe	1
77	9.802-437.0	▲ Cord, Service, SO , 10/4, (6-3C; 8-3C; 10-2C)	8.25 ft.
	9.803-992.0	▲ Cord, Service, SO, 4/4, (8-3B, H; 10-2B)	8.25 ft.
	8.715-933.0	▲ Cord, Service, SO, 6/4, (6-3B,)	8.25 ft.
	9.802-522.0	▲ Strain Relief, 1"	1
78	8.716-269.0	Box, Metal, 12" x 12" x 4" (Optional)	1
79	9.802-792.0	Nut, 3/8" x 12 Gauge, Cage	22
80	8.912-514.0	Cover, Burner Access	1
81	8.719-936.0	Ring, Insulation Retainer	1
82	9.802-039.0	Elbow, 1/2 JIC x 3/8 MPT	1
83	9.149-003.0	Manifold Coil Outlet	1
84	8.706-248.0	Plug, 3/8"	1

▲ Not Shown

# CONTROL PANEL ASSEMBLY

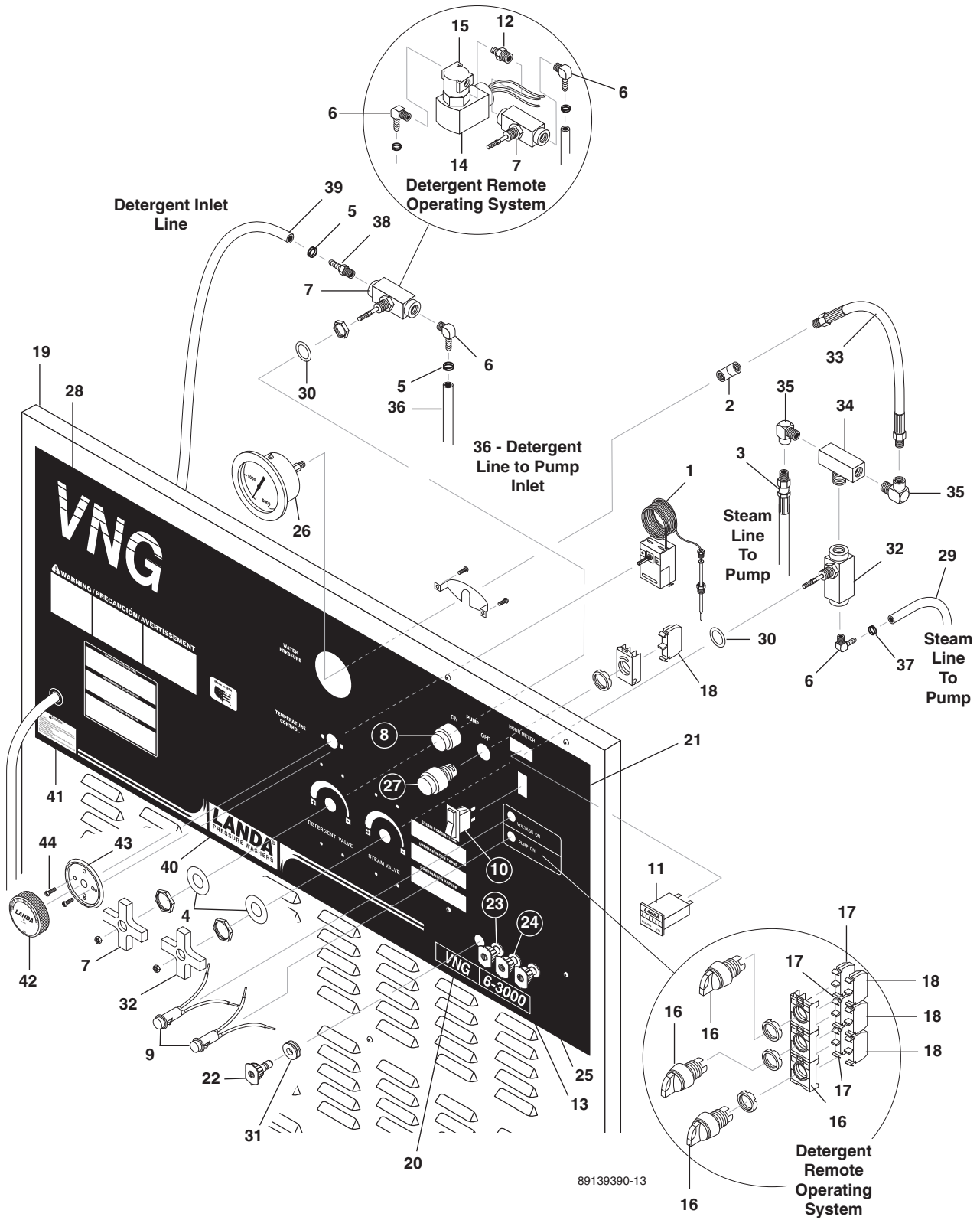

89139390-13

## CONTROL PANEL PARTS LIST

ITEM	PART NO.	DESCRIPTION	QTY	ITEM	PART NO.	DESCRIPTION	QTY
1	8.750-094.0	Thermostat, 302°	1		8.712-378.0	Nozzle, 0009 Red (8-3)	1
2	8.706-162.0	Elbow, 1/4" Female Pipe	1		8.712-386.0	Nozzle, 0015 Red (10-2)	1
3	8.918-419.0	Hose, 1/4" x 36", 2 Wire Ga. (S)	1	23	8.712-358.0	Nozzle, 15055 Yellow (4-2)	1
4	9.802-810.0	Washer, 5/8" Flat	2		8.712-350.0	Nozzle, 1504.5 Yellow (4-3)	1
5	9.802-210.0	Clamp, Hose, UNI .46 - .54	2		8.712-370.0	Nozzle, 1502 Yellow (6)	1
6	8.706-958.0	Hose Barb, 1/4" Barb, 90°	3		8.712-379.0	Nozzle, 1509 Yellow (8-3)	1
7	8.707-317.0	Valve, Control Metering	1		8.712-387.0	Nozzle, 1515 Yellow (10-2)	1
8	8.751-916.0	Switch Green, Push Button	1	24	8.712-359.0	Nozzle, 2505.5 Green (4-2)	1
	8.751-910.0	Switch, 2 Position, (Auto Start Option)	1		8.712-351.0	Nozzle, 2504.5 Green (4-3)	1
9	9.802-455.0	Light, Indicator, Green, 125V	2		8.712-371.0	Nozzle, 2507 Green (6-3)	1
10	9.802-453.0	Switch, Curvette (Burner)	1		8.712-380.0	Nozzle, 2509 Green (8-3)	1
11	9.802-283.0	Meter, Hour	1		8.712-388.0	Nozzle, 2515 Green (10-2)	1
12	8.706-780.0	Nipple, 1/4" Hex	1	25	8.712-360.0	Nozzle, 4005.5 White (4-2)	1
13	8.900-409.0	Label, 4-2000	1		8.712-352.0	Nozzle, 4004.5 White (4-3)	1
	8.900-411.0	Label, 4-3000	1		8.712-372.0	Nozzle, 4007 White (6-3)	1
	8.900-417.0	Label, 6-3000	1		8.712-381.0	Nozzle, 4009 White (8-3)	1
	8.940-171.0	Label, 8-3000	1		8.712-389.0	Nozzle, 4015 White (10-2)	1
	8.900-422.0	Label, 10-2000	1	26	8.712-150.0	Gauge, 0-5000 PSI	1
14	9.802-533.0	Solenoid Coil, 120V (Remote)	1	27	8.751-915.0	Switch, Red, Push Button	1
15	9.802-532.0	Valve, Det. Less Coil (Remote)	1	28	8.900-791.0	Label, VNG Logo	1
16	8.751-914.0	Switch, Selec (Remote)	3	29	9.802-254.0	Hose, 1/4", Push-On, (Small) (Large)	36" 40"
17	8.751-913.0	Block, Con. N/O Auto Start (Remote w/Auto Start) Time Delay (Remote w/Time Delay)	1 4 1 3	30	8.719-011.0	Washer, 5/8" Star	2
18	8.751-912.0	Block, Con. N/C Time Delay (Remote w/Auto Start) (Remote w/Time Delay)	2 2 3	31	9.802-064.0	Grommet, Rubber, Nozzle	4
19	8.912-537.0	Panel, Control, VNG Small	1	32	9.802-187.0	Valve, Metering Steam	1
	8.912-511.0	Panel, Control, VNG Large	1	33	8.918-180.0	Hose, 1/4" x 16", 2 Wire Gauge	1
20	8.900-261.0	Label, VNG Lexan	1	34	8.706-213.0	Tee, 1/4" Branch Male, Steel	1
	8.900-260.0	Label, VLP Lexan	1	35	8.706-200.0	Elbow, 1/4" Street	2
21	8.900-808.0	Label, VNG Control Panel	1	36	9.802-252.0	Tube, Braided Vinyl (Small) (Large)	36" 41"
	8.900-790.0	Label, VNG Control Panel (Auto Start Option)	1	37	8.709-069.0	Clamp, Screw	1
	8.900-804.0	Label, VNG Control Panel (Remote Option)	1	38	8.706-941.0	Hose Barb, 1/4" Barb x 1/4	1
22	8.712-349.0	Nozzle, 0004.5 Red (4-3)	1	39	9.802-251.0	Tube, 1/4" x 1/2", Clear Vinyl	10 ft.
	8.712-357.0	Nozzle, 0005.5 Red (4-2)	1		8.707-058.0	▲ Strainer, 1/4" Brass	1
	8.712-369.0	Nozzle, 0007 Red (6-3)	1	40	8.900-832.0	Label, Landa Stripe	1
				41	9.800-049.0	Label, Manuf. Cleaning Solution	1
				42	8.750-096.0	Knob, Thermostat 302°	1
				43	8.712-190.0	Bezel, Thermostat	1
				44	8.718-779.0	Screw, 4 mm x 6 mm	2

▲ Not Shown

# VNG 6-3000, 8-3000 BURNER ASSEMBLY

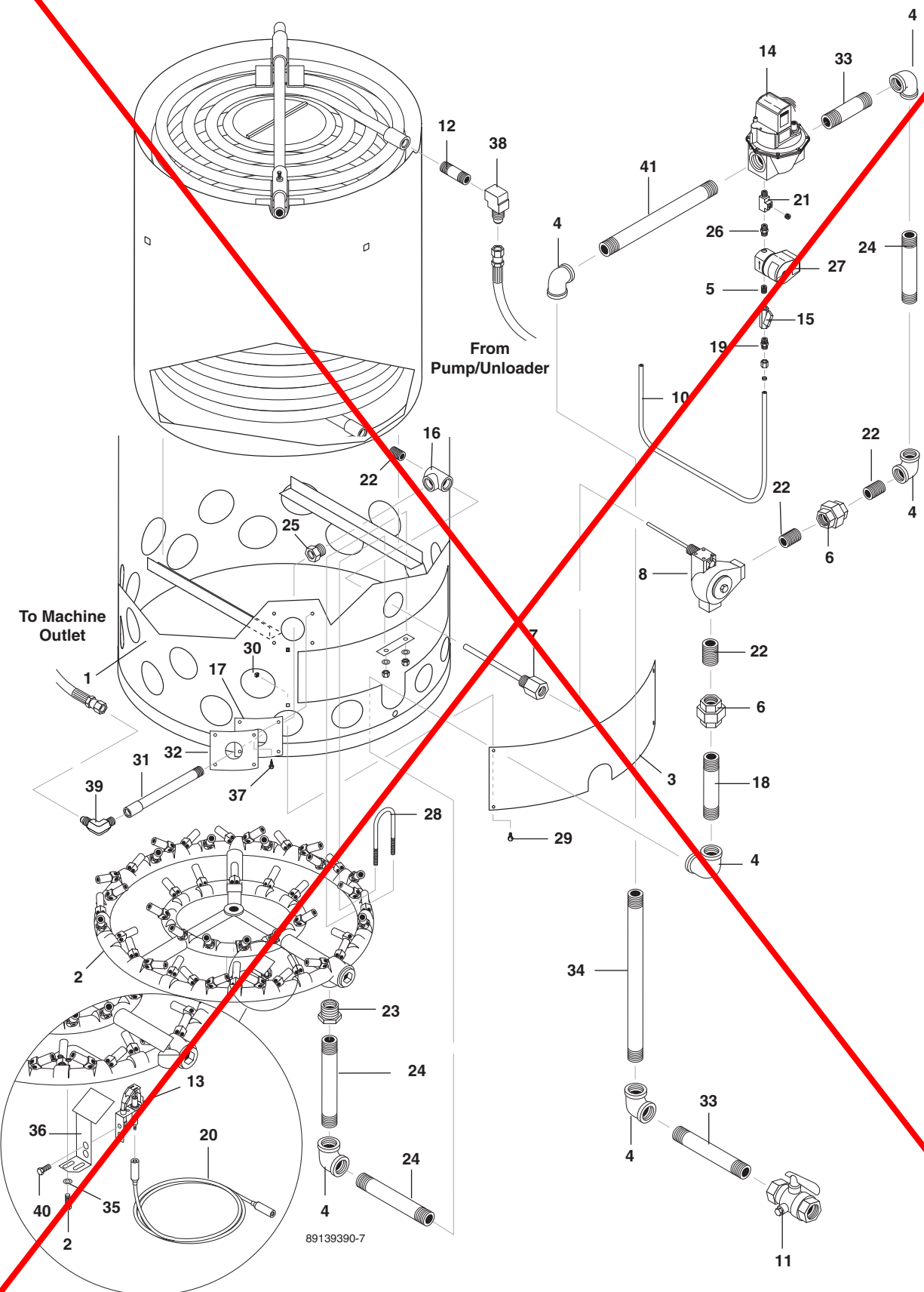

89139390-7

## VNG 6-3000, 8-3000 BURNER PARTS LIST

ITEM	PART NO.	DESCRIPTION	QTY	ITEM	PART NO.	DESCRIPTION	QTY
1	8.912-553.0	Module, Wrap, Outer, Large Coil	1	22	8.706-118.0	Nipple, 1" Close, 3500 PSI	3
2	8.751-384.0	Burner Ring x-96 Nozzles W/# 54 NG	1	23	8.706-047.0	Bushing, Pipe 1 1/4" x 1 Blk	1
	8.749-969.0	Burner Ring x-88 Nozzles W/# 64 (LP Option)	1	24	8.706-019.0	Nipple, 1" x 5" Black Pipe	3
3	8.912-550.0	Door, Burner, Large	1	25	8.706-038.0	Bushing, 1" x 1/2" 3M F/S	1
4	9.802-026.0	Elbow, 1", Black Pipe, 90°	6	26	8.706-878.0	Nipple, 1/4" Pipe x 1/8" Pipe	1
5	8.706-777.0	Nipple, 1/4" Close	1	27	9.803-612.0	Solenoid, Pilot	1
6	8.706-323.0	Union, 1", Black Pipe	2	28	9.802-719.0	U-Bolt, 5/16" x 3", Pipe	2
7	8.718-088.0	Well, Pressure, Modulating Thermostat	1	29	9.802-754.0	Bolt, 1/4" x 1/2" Whiz Loc	4
8	8.718-087.0	Modulating Thermostat KimRay	1	30	9.802-794.0	Nut, Cage, 1/4" x 12 Gauge	4
9	9.802-027.0	Elbow, 3/4", Black, 90°	2	31	8.912-694.0	Extension, Outlet	1
10	9.802-911.0	Tubing, Aluminum, 600 RL, 1/4" Dead Soft	40"	32	9.803-132.0	Plate, Insulation Retainer	1
11	8.718-062.0	Valve, Gas Shut-Off, 1" MPT	1	33	8.706-050.0	Nipple, 1" x 8" Black Pipe	2
12	9.802-014.0	Nipple, 1/2" x 3", Galvanized	1	34	8.719-959.0	Nipple, 1" x 18" Black Pipe	1
13	9.803-610.0	Pilot, Ignitor	1	35	9.802-802.0	Washer, 1/4" Flat SAE	2
14	8.718-050.0	Valve, Gas V8943B1010/B (NG)	1	36	8.916-932.0	Splash Guard, Pilot Light	1
	8.718-048.0	Valve, Gas, V8943C1018 (LP)	1	37	9.802-798.0	Screw, #10 x 1/2" Tek Hex	4
15	9.802-178.0	Valve, Ball, 1/4" Female x 1/4" Female	1	38	8.802-043.0	Elbow, 1/2" JIC x 1/2" Female	1
16	8.706-094.0	Tee, Black Steel, 3000 PSI	1	39	9.802-040.0	Elbow, 1/2" JIC x 1/2" MPT	1
17	8.933-009.0	Gasket, Burner Plate	1	40	9.802-772.0	Screw, 10/32" x 1/4" Hex	2
18	8.706-024.0	Nipple, 1" x 4" Black Pipe	1	41	8.706-022.0	Nipple, 1" x 6"	1
19	9.802-159.0	Connector, 1/4" Tube x 1/4" MPT	2				
20	9.803-562.0	Cable, Ignitor, 48"	1				
21	8.706-857.0	Tee, 1/8" Street	1				

# VNG-L 10-2000 BURNER ASSEMBLY

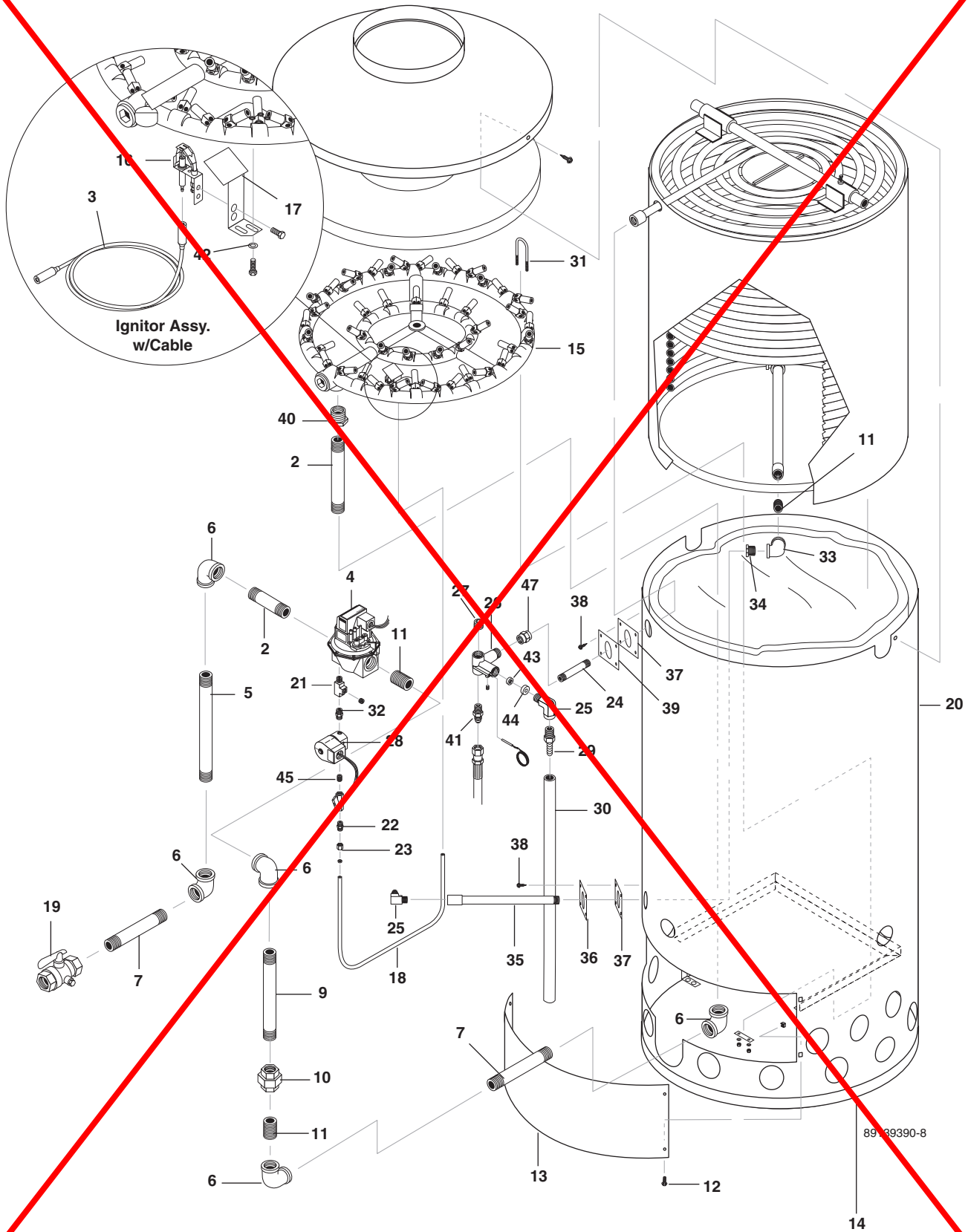

## VNG-L 10-2000 BURNER PARTS LIST

ITEM	PART NO.	DESCRIPTION	QTY	ITEM	PART NO.	DESCRIPTION	QTY
1	9.802-028.0	Elbow, 1" x 3/4" Reducing, Blk	2	31	9.802-719.0	U-Bolt, 3/16" x 3" Pipe	2
2	8.706-019.0	Nipple, 1" x 5", Black Pipe	2	32	8.706-878.0	Nipple, 1/4" Pipe x 1/8" Pipe	1
3	9.803-562.0	Cable, Ignitor, 48"	1	33	8.706-206.0	Elbow, 1/2" Black Pipe	1
4	8.718-050.0	Valve, Gas, V8943B1010/B (NG)	1	34	8.706-038.0	Bushing, 1" x 1/2" 3M F/S	1
	8.718-048.0	Valve, Gas, V8943C1018 (LP)	1	35	8.912-694.0	Extension, Outlet	1
5	8.719-959.0	Pipe, 1" NPT x 18" Blk Sch.40	1	36	9.803-132.0	Plate, Insulation Retainer	1
6	9.802-026.0	Elbow, 1", Black Pipe, 90°	5	37	8.933-009.0	Gasket, Burner Plate	2
7	8.706-050.0	Nipple, 1" x 8" Black Pipe	2	38	9.802-798.0	Screw, #10 x 1/2" Tek, Hex Head	16
8	9.802-772.0	Screw, 10/32" x 1/4"	2	39	8.912-520.0	Plate, Cover, NG, LM w/Hole	1
9	8.706-021.0	Pipe, 1" NPT x 11", Black Pipe, Sch. 40	1	40	8.706-047.0	Pipe, Bushing 1 1/4" x 1" Blk	1
10	8.706-323.0	Union, 1", Black Pipe	1	41	9.802-127.0	Nipple, 1/2" JIC x 3/8" MPT Brass	1
11	8.706-118.0	Nipple, 1", Close, 3500 PSI	2	42	9.802-802.0	Washer, 1/4" Flat SAE	2
12	9.802-754.0	Screw, 1/4" x 1/2" HH NC, Whiz Loc	4	43	8.725-944.0	Disk, Rupture, 8000	1
13	8.912-550.0	Door, Burner, Large	1	44	9.814-030.0	Spacer, Rupture Disk	1
14	9.802-794.0	Nut, Cage, 1/4" x 12 Gauge	4	45	8.706-777.0	Nipple, 1/4" Close	1
15	8.751-384.0	Burner Ring x-96 Nozzles W/#54 (NG) 1		46	8.912-522.0	▲ Plate Cover, NC, LM w/o Hole	1
	8.749-969.0	Burner Ring x-88 Nozzles W/#64 Jets (LP Option)	1	47	8.706-141.0	Coupling, 1/2" Steel Pipe	1
16	9.803-610.0	Pilot, Ignitor	1			▲ Not Shown	
17	8.916-932.0	Splash Guard, Pilot Light	1				
18	9.802-911.0	Tubing, 1/4" Aluminum	40"				
19	8.718-062.0	Valve, Gas, Shut-Off, 1" MPT	1				
20	8.912-553.0	Wrap, Outer, 30" Large Coil	1				
21	8.706-857.0	Tee, 1/8" Street	1				
22	9.802-178.0	Valve, 1/4" Johnar T-91LP Ball	1				
23	9.802-159.0	Connector Tube, 1/4" x 1/4" MPT	2				
24	9.802-014.0	Nipple, 1/2" x 3" Galvanized	1				
25	8.706-207.0	Elbow, 3/8" STR 90° Steel	1				
26	9.149-003.0	Manifold, Coil Outlet Discharge	1				
27	8.706-248.0	Plug, 3/8" Counter Sunk, Allen	1				
28	9.803-612.0	Solenoid, Pilot	1				
29	8.707-019.0	Hose Barb, 1/2" Barb x 3/8" MPT	1				
30	9.802-259.0	Hose, 1/2" Push-On	4.25 ft.				

# VNG ELECTRICAL BOX - AUTO START

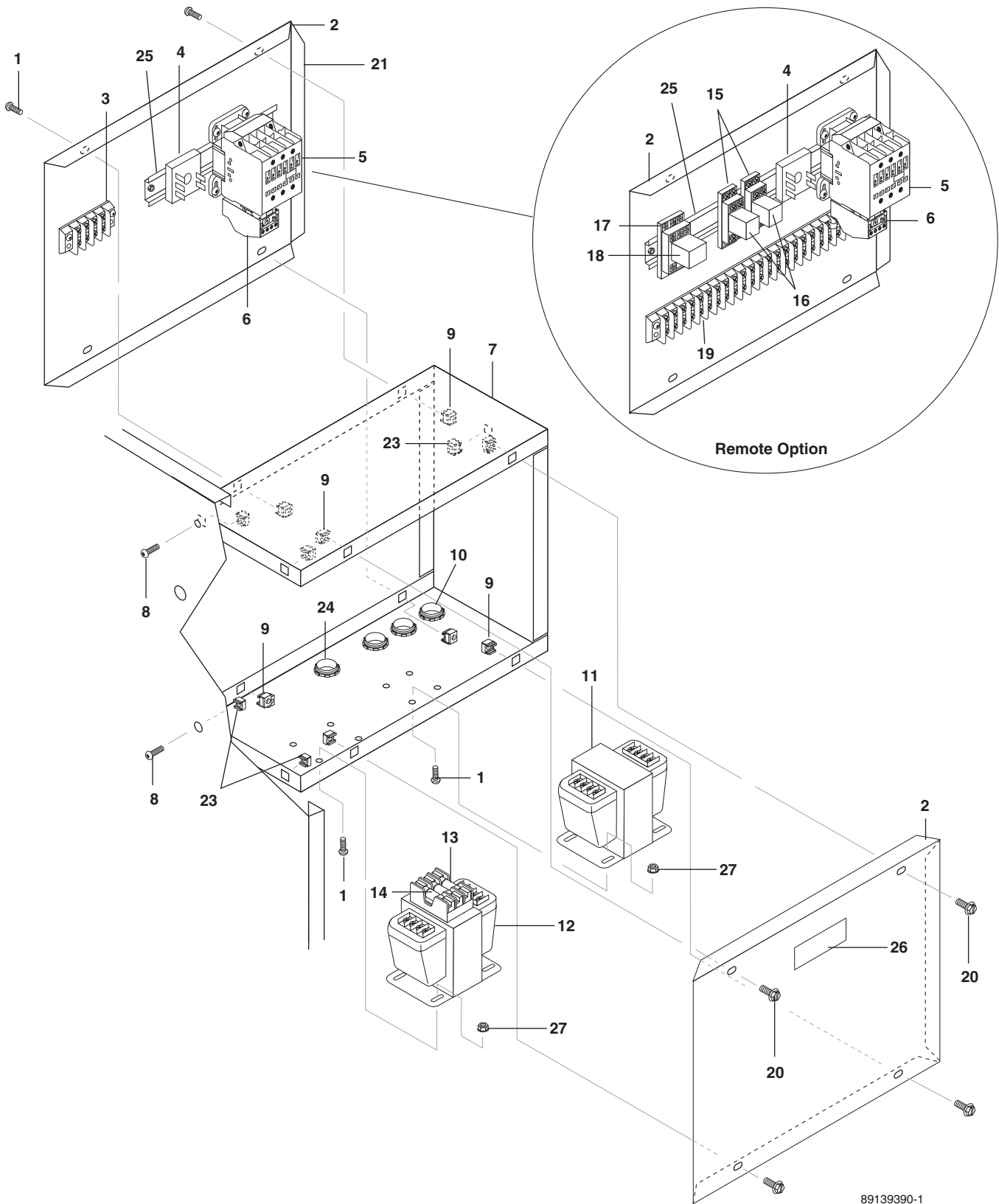

89139390-1

## VNG ELECTRICAL BOX - AUTO START PARTS LIST

ITEM	PART NO.	DESCRIPTION	QTY	ITEM	PART NO.	DESCRIPTION	QTY
1	9.802-759.0	Screw, 10/32" x 1/2" BHSOC	15	12		Transformer, See Specifications Pages	
2	9.802-970.0	Panel, Electrical Box, Side	2	13		Primary Fuse, See Specifications Pages	
3	9.802-491.0	Block, Terminal, 4 Pole	1	14		Secondary Fuse, See Spec's Pages	1
	9.802-749.0	▲ Screw, 8/32" x 3/4"	2	15	9.802-467.0	Base, Relay IDEC (Remote Option)	2
	9.802-785.0	▲ Nut, 8/32" Keps	2	16	9.802-468.0	Relay, 120V, IDEC (Remote Option)	2
4	9.802-472.0	Timer, Solid State 120V, 5-60 Min. Lockout	1	17	8.752-146.0	Relay, Socket Remote	1
5		Contactor, See Specifications Pages		18	8.752-141.0	Relay, Latch, Remote	1
6		Overload Relay, See Specifications Pages		19	9.802-493.0	Block, Terminal, 16 Pole, Remote	1
7	9.802-969.0	Box, Electrical VNG	1	20	9.802-764.0	Screw, 10/32" x 3/4" Hex	4
8	9.804-003.0	Screw, 1/4" x 3/4" BH SOC	4	21	9.802-762.0	▲ Screw, 10/32" x 1-1/4"	1
9	9.802-791.0	Nut, Cage 10/32" x 16 Gauge	8		9.802-695.0	▲ Nut, Keps, 10/32"	6
10	9.802-520.0	Strain Relief, 3/4" (4-2;4-3;6-3C,8-3C, 10-2C,) Remote Option (6-3B, 8-3B, H; 10-2B)	3 1	22	9.802-771.0	▲ Screw, 10/32" x 3/4"	1
	9.802-522.0	Strain Relief, 1" (6-3B,)	2	23	9.802-793.0	Nut, Cage, 1/4" x 16 Gauge	5
	9.803-975.0	Strain Relief, CG 100-1050 1" Blk (4/4 COR) (8-3B, H; 10-2B)	2	24	9.802-520.0	Strain Relief, 3/4" (Remote Option)	1
11		Transformer, See Specifications Pages		26	9.800-016.0	Label, Power disconnect	1
				27	9.802-695.0	Nut 10/32 Keps	8

▲ Not Shown

## VNG ELECTRICAL BOX - TIME DELAY

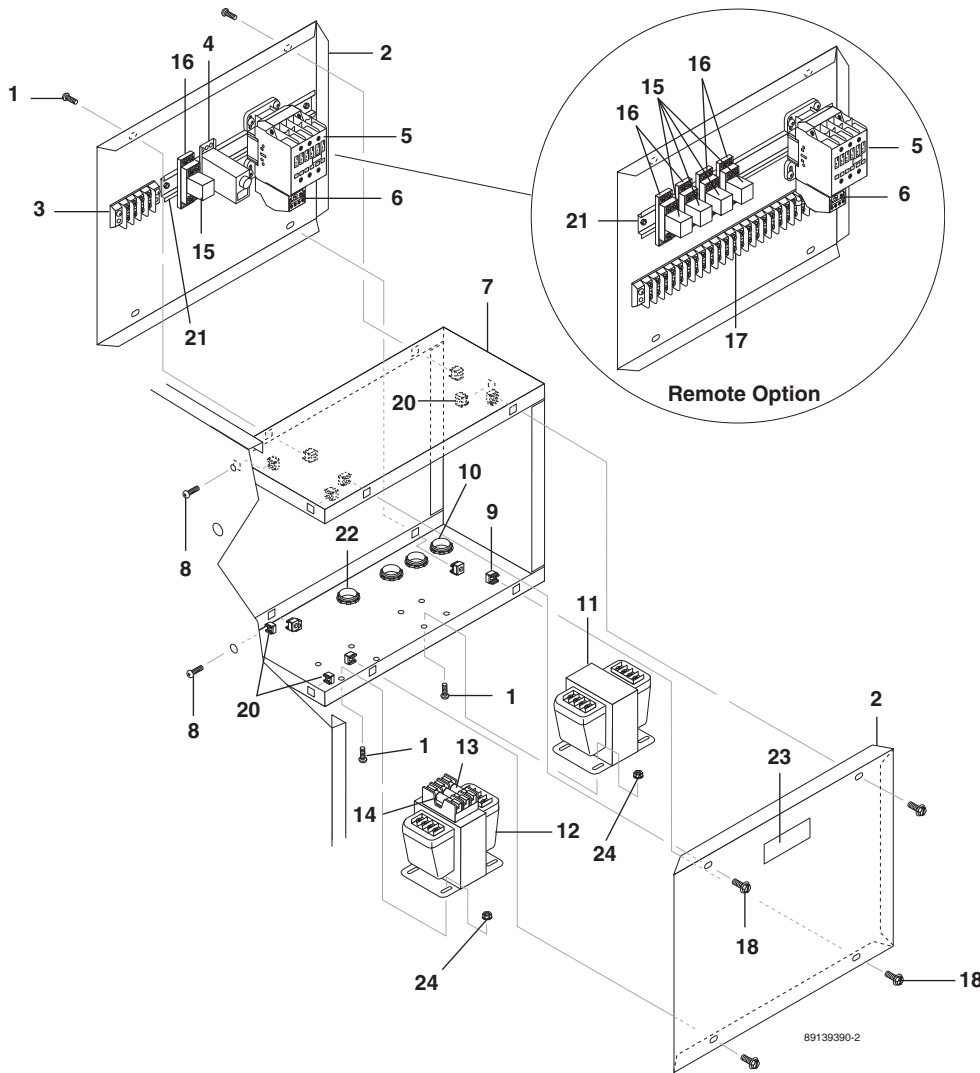

## VNG ELECTRICAL BOX - TIME DELAY PARTS LIST

ITEM	PART NO.	DESCRIPTION	QTY	ITEM	PART NO.	DESCRIPTION	QTY
1	9.802-759.0	Screw 10/32" x 1/2" BHSOC	15	14	Secondary Fuse, See Specifications Pages		
2	9.802-970.0	Panel, Electrical Box, Side	2	15	9.802-467.0	Base, Relay IDEC (Remote Option)	1 4
3	9.802-491.0	Block, Terminal, 4 Pole	1	16	9.802-468.0	Relay, 120V, IDEC (Remote Option)	1 4
	9.802-749.0	▲ Screw, 8/32" x 3/4" BHSOC	2	17	9.802-493.0	Block, Terminal, 16 Pole, (Remote Option)	1
	9.803-676.0	▲ Nut, 8/32" ESNA	2	18	9.802-764.0	Screw, 10/32" x 3/4" Hex	4
4	8.751-306.0	Timer, Multi Function 24V - 120/240V 5A	1	19	9.802-771.0	▲ Screw, 10/32" x 3/4"	1
5	Contactor, See Specifications Pages				9.802-695.0	▲ Nut, Keps, 10/32"	6
6	Overload Relay, See Specifications Pages			20	9.802-793.0	Nut, Cage, 1/4" x 16 Gauge	5
7	9.802-969.0	Box, Electrical VNG	1	21	9.802-457.0	Din Rail (Option)	7" 12"
8	9.804-003.0	Screw, 1/4" x 3/4" BH SOC	4	22	9.802-520.0	Strain Relief, 3/4" (Remote Option)	1
9	9.802-791.0	Nut, Cage, 10/32" x 16 Gauge	8	23	9.800-016.0	Label, Power disconnect	1
10	9.802-520.0	Strain Relief, 3/4" (Remote Option)	1	24	9.802-695.0	Nut, Keps, 10/32"	8
11	Transformer, See Specifications Pages						
12	Transformer, See Specifications Pages						
13	Primary Fuse, See Specifications Pages						

▲ Not Shown

# VNG REMOTE ELECTRICAL BOX - ALL MODELS

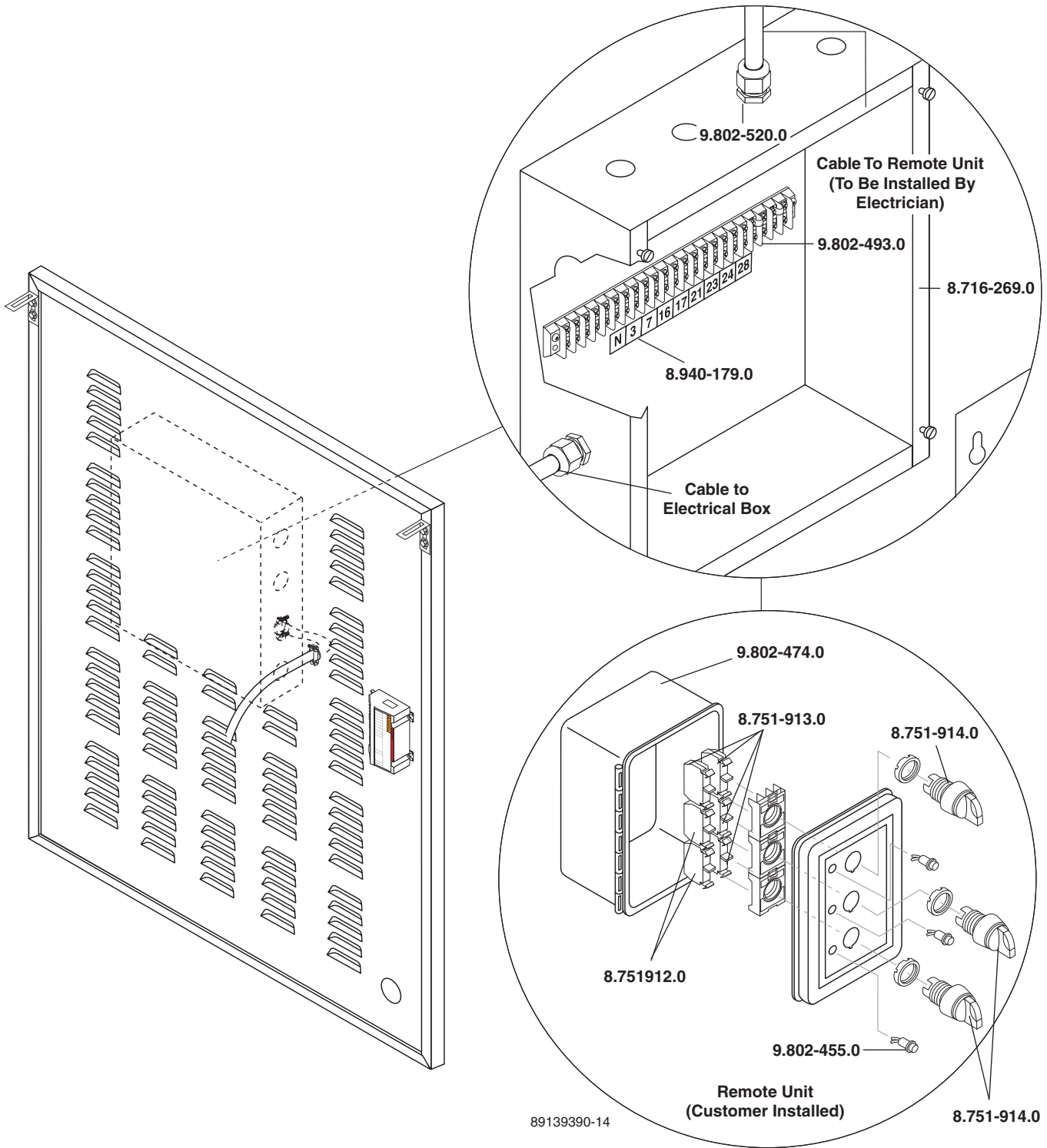

# VNG HANDHELD WIRELESS EXPLODED VIEW & PARTS LIST

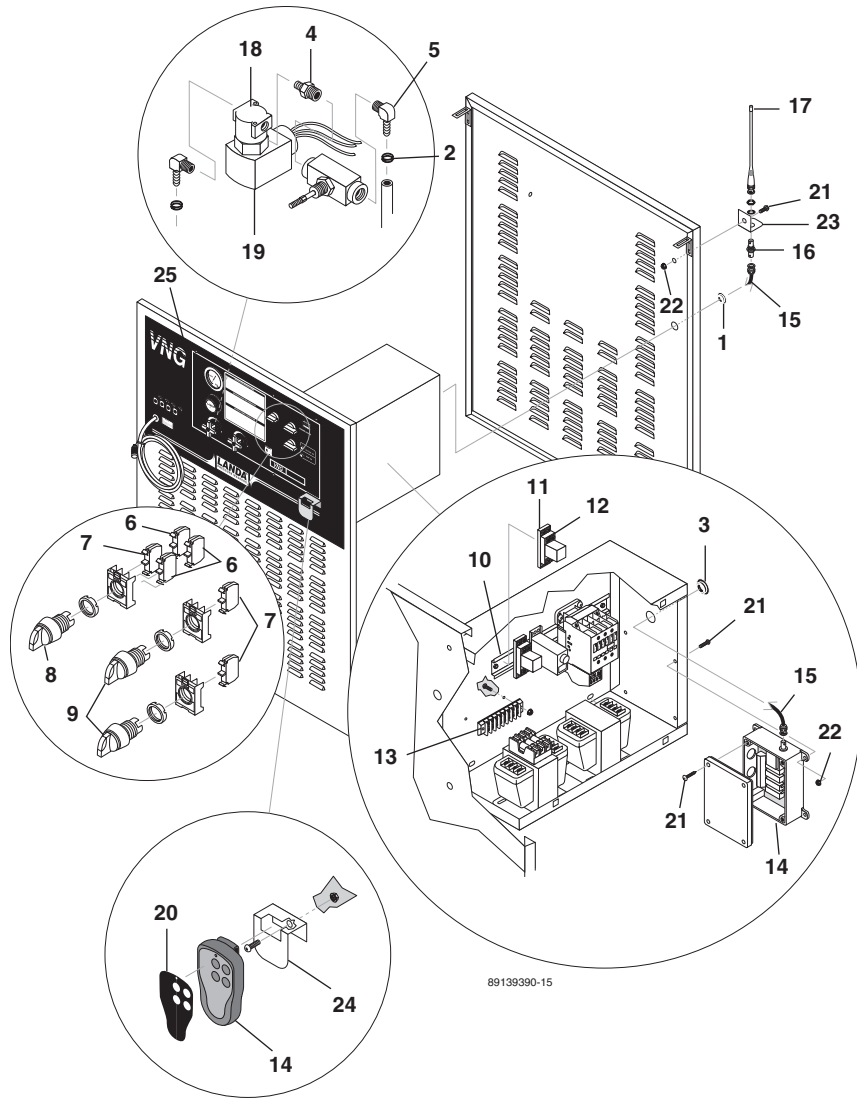

89139390-15

ITEM	PART NO.	DESCRIPTION	QTY
1	8.706-755.0	Bushing, .875"	1
2	6.390-126.0	Clamp, Hose	2
3	9.802-104.0	Bushing, 3/4" Snap	1
4	8.706-777.0	Nipple, 1/4" Close	1
5	8.706-958.0	Hose Barb, 1/4" Barb x 1/4" Pipe, 90°	2
6	8.751-912.0	Block, Contact, N/C	3
7	8.751-913.0	Block, Contact, N/O	3
8	8.751-914.0	Switch, Selector	1
9	8.716-718.0	Switch, 2 Position	2
10	9.802-457.0	Din Rail, 35mm	6.5
11	9.802-467.0	Base, Relay, SH2B-05, IDEC	1
12	9.802-468.0	Relay, 120V, RH2B-UL-AC120	1
13	9.802-492.0	Block, Terminal, 8 Pole	1
14	8.716-442.0	Wireless, Transmitter-Receiver 4 Relay	1
15	8.716-444.0	Cable Radio Remote, CC58C-5 Coaxial Cable	1

ITEM	PART NO.	DESCRIPTION	QTY
16	8.716-445.0	Connector, Radio Remote BNC Connection	1
17	8.716-446.0	Antenna, Radio Remote BNC Connection	1
18	9.802-532.0	Valve, Chem. Less Solenoid 04F20C2118AAF	1
19	9.802-533.0	Solenoid Coil, 120C AF4C05	1
20	8.940-008.0	Label, Land, Lancom Remote Control	1
21	9.802-749.0	Screw, 8/32" x 3/4" BHSOC	7
22	9.802-785.0	Nut, 8/32", KEPS	7
23	8.912-674.0	Bracket, Antenna Mount, Wireless Remote	1
24	8.912-675.0	Bracket, Trans, Wireless Rem	1
25	8.900-804.0	Label, VNG Cont. Panel w/Remote	1

# VNG HANDHELD WIRELESS OPERATING INSTRUCTIONS

## Wireless Remote Control Operation

### Step 1: Pressure Washer Operation

Once the main circuit breaker power to the machine is turned on, the pump can be controlled either at the machine control panel or with the remote transmitter.

To remotely turn pump "ON", press transmitter button #1. To turn pump "OFF" press button #2. Pump can be turned off at the machine by turning the control panel pump switch to the "OFF" position.

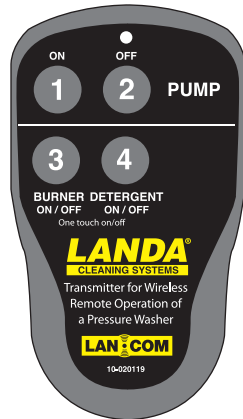

TRANSMITTER

### Step 2: Burner Operation

To operate burner in remote mode turn control panel burner switch to the "ON" position. Note: Burner remote will only work when the machine control panel Burner switch is in the "ON" position.

Remotely control burner by pressing transmitter button #3 to turn burner "OFF". Pressing button #3 again will turn burner "ON".

The control panel burner switch will be non-functional if burner is turned "OFF" remotely. To re-activate the control panel burner switch either press button 3 to turn burner "ON" or turn control panel pump switch "OFF".

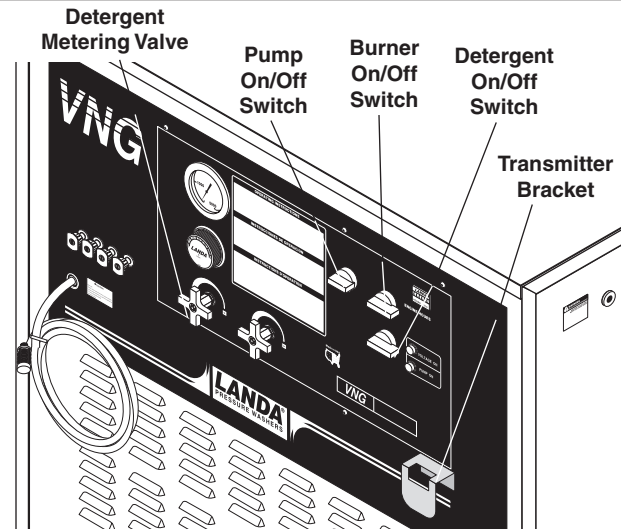

### Step 3: Detergent Operation

The machine has an electronic solenoid to operate detergent flow. To operate detergent in remote mode, adjust the detergent metering valve to the desired flow and turn control panel detergent switch to the "ON" position. Note: Detergent remote will only work when the machine control panel detergent switch is in the "ON" position.

Remotely control detergent by pressing transmitter button #4 to turn detergent "OFF". Pressing button #4 again will turn detergent "ON".

The control panel detergent switch will be non-functional if detergent is turned "OFF" remotely. To re-activate the control panel switch either press button #4 to turn detergent "ON" or turn control panels pump switch "OFF".

**NOTE: The wireless remote option has Time Delay Shutdown installed and will shut down after 3-5 minutes of no use.**

**If machine times out while using remotely, press the pump "OFF" button to reset the timer. Press transmitter pump "ON" button to restart pump.**

# VNG 4-2000, 4-3000, 6-3000 PUMP ASSEMBLY

## 4-2000 & 4-3000

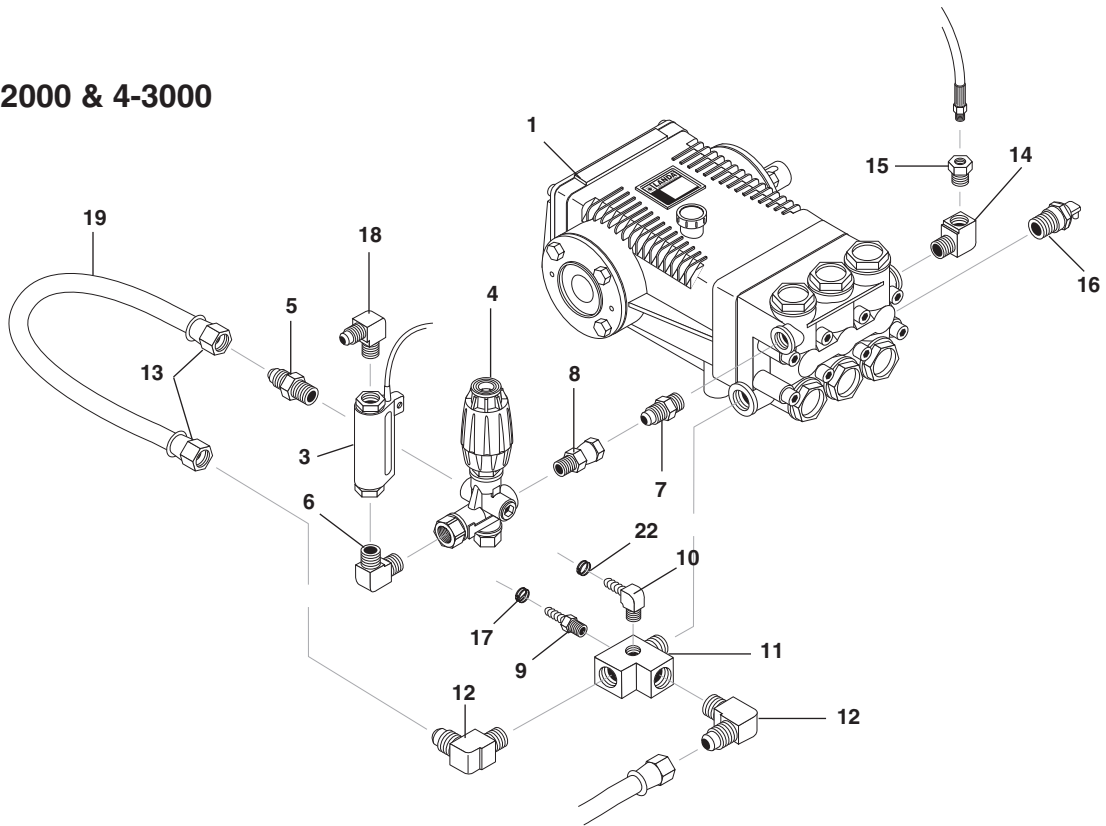

## 6-3000

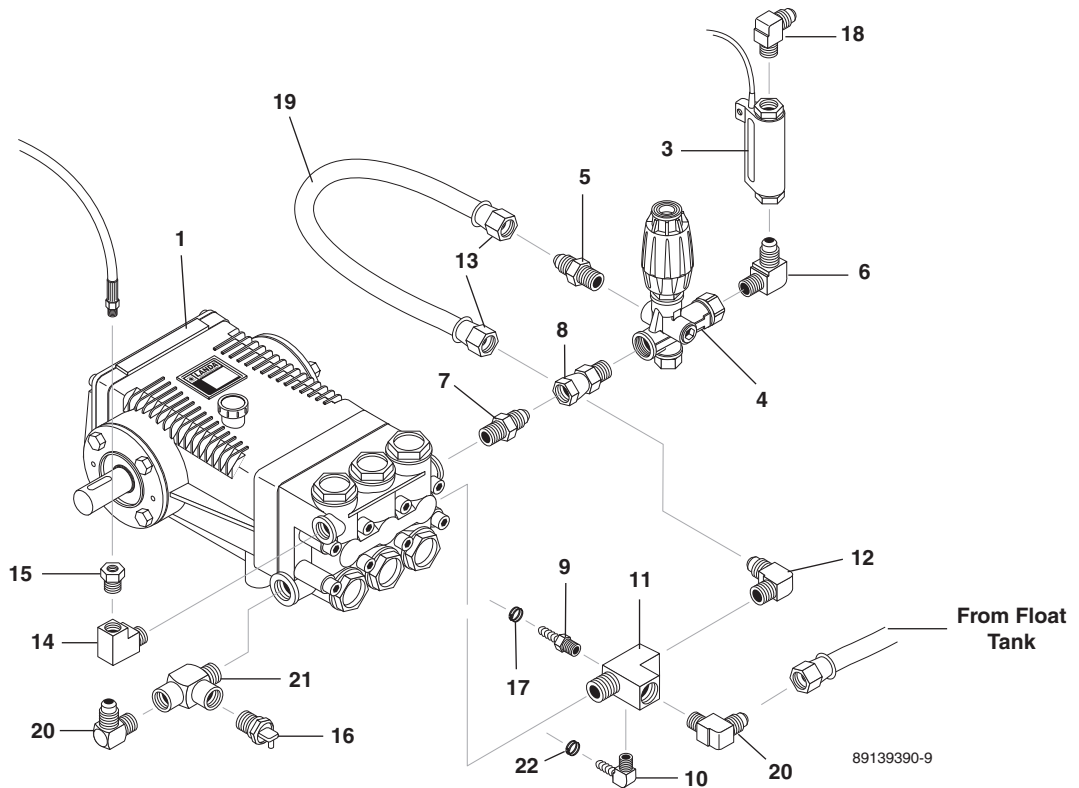

## VNG 4-2000, 4-3000, 6-3000 PARTS LIST

ITEM	PART NO.	DESCRIPTION	QTY
1		Pump, See Parts Specifications Pages	
2	9.803-131.0	▲ Rail, Pump	1
3	8.933-006.0	Switch, Flow MV60, Yellow	1
4	8.750-299.0	Unloader, VRT3, 8 GPM @4500 PSI	1
	9.802-362.0	Unloader, PA 8 GPM@3650, w/Switch (Auto Start)	1
5	9.802-127.0	Nipple, 1/2" JIC x 3/8" Pipe	1
6	8.706-168.0	Elbow, 3/8", Male Pipe	1
7	9.802-036.0	Nipple, 1/2" JIC x 3/8" Pipe	1
	9.802-048.0	Swivel, 1/2" JIC Fem, 3/8" Male (Auto Start Option)	1
8	9.802-048.0	Swivel, 1/2" JIC Fem, 3/8" Male	1
	9.802-037.0	Nipple, 1/2" JIC, 3/8" Female (Auto Start Option)	1
9	8.706-940.0	Hose Barb, 1/4" Barb x 1/8" Male Pipe	1
10	8.706-955.0	Hose Barb, 1/4" x 1/8" 90°	1
11	9.803-050.0	Tee, 1/2" Street w/2 Holes	1
12	9.802-131.0	Elbow, 1/2" JIC x 1/2", 90° (6-3)	1
		(4-2, 4-3)	2
13	9.802-151.0	Swivel, 1/2" JIC Female	2
14	8.706-207.0	Elbow, 3/8" Street	1
15	8.706-297.0	Bushing, 3/8" x 1/4", Galv.	1
16	8.707-256.0	Pump Protector, 1/2" PTP	1
17	6.390-126.0	Clamp, Hose, .46 -, .54 ST	1
18	9.802-039.0	Elbow, 1/2" JIC x 3/8" Male	1
19	9.802-259.0	Hose, 1/2", Push On	1.25"
20	9.802-132.0	Elbow, 3/4" JIC x 1/2" (6-3)	2
21	8.706-860.0	Tees, 1/2" Street (6-3)	1
22	8.709-069.0	Clamp, Screw, #4	1

▲ Not Shown

# VNG 8-3000, 10-2000 PUMP ASSEMBLY

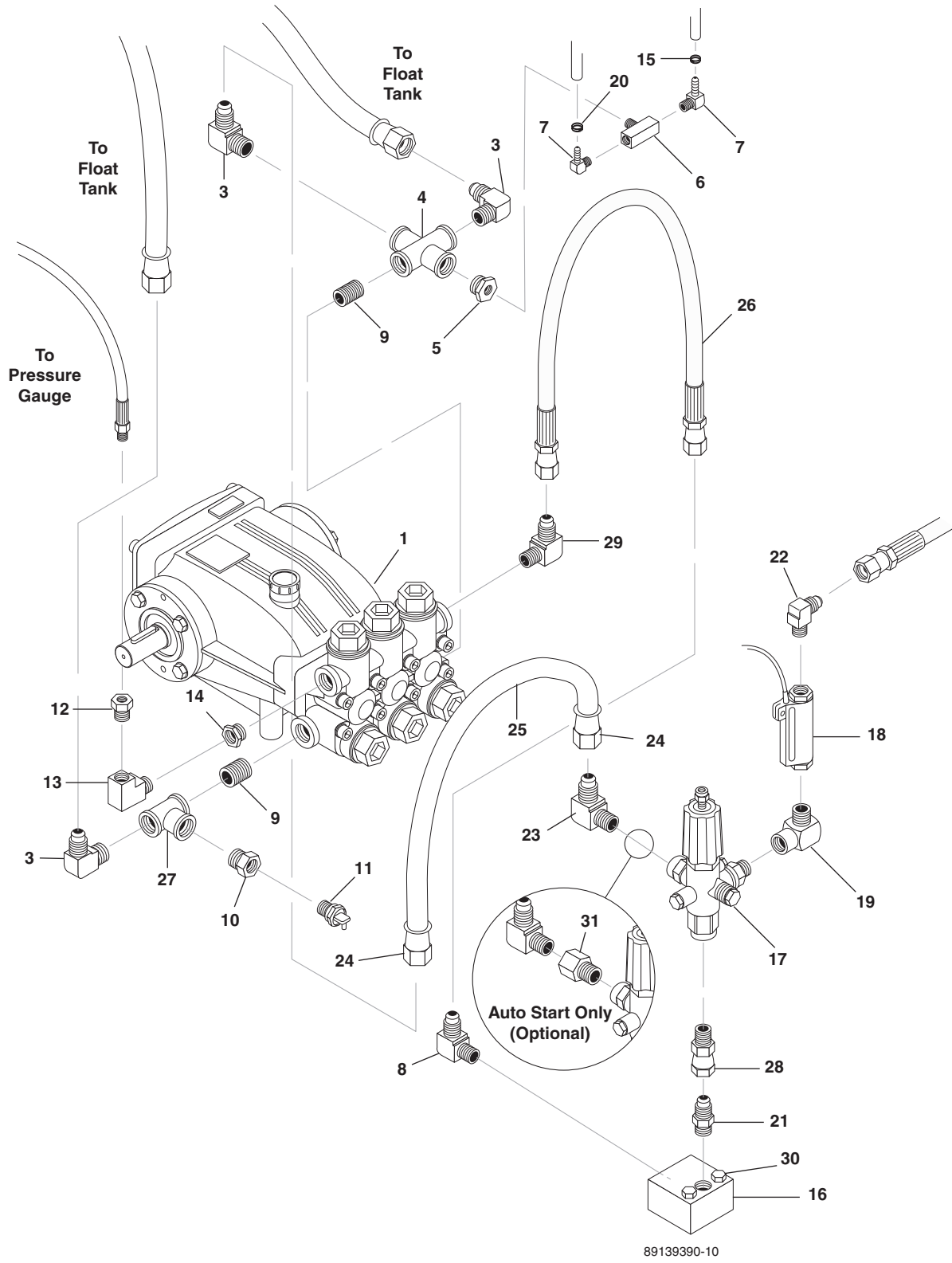

## VNG 8-3000, 10-2000 PARTS LIST

ITEM	PART NO.	DESCRIPTION	QTY	ITEM	PART NO.	DESCRIPTION	QTY
1	8.920-590.0	Pump, Landa LX9536/L (8-3)	1	20	8.709-069.0	Clamp, Screw, #4	1
	8.920-592.0	Pump, Landa LX1036/L (10-2)	1	21	9.802-038.0	Nipple, 1/2" x 1/2" JIC (8-3, 10-2)	1
2	8.912-215.0	▲ Rail, Pump Combo	1		9.802-048.0	Swivel, 1/2" JIC Fem x 3/8" Male (8-3 Auto Start Option)	1
3	9.803-557.0	Elbow, 3/4" SAE x 3/4", 90°, Brass	3	22	9.802-039.0	Elbow, 1/2" JIC, 3/8", 90°	1
4	8.706-852.0	Cross, 3/4" Female Pipe	1	23	9.802-132.0	Elbow, 3/4" JIC x 1/2", 90° (8-3, 10-2)	1
5	8.706-923.0	Bushing, 3/4" x 1/4" Pipe	1	24	9.802-152.0	Swivel, 3/4" SAE Female, Push-On	2
6	8.706-854.0	Tee, 1/4" Branch, Male	1	25	9.802-261.0	Hose, 3/4" Push-On	2 ft.
7	8.706-958.0	Hose Barb, 1/4" Barb x 1/4" Pipe, 90°	2	26	8.918-225.0	Hose, 1/2" x 28", 2 Wire	1
8	9.802-039.0	Elbow, 1/2" JIC x 3/8" MPT (Auto Start Option)	1	27	8.706-846.0	Tee, 3/4" Female, Brass	1
	9.802-039.0	Elbow, 1/2" JIC, 1/2" 90°	1	28	9.802-037.0	Nipple, 1/2" JIC x 3/8" Fem (8-3 Auto Start Option)	1
9	8.706-799.0	Nipple, 3/4" Close	2		8.706-315.0	Swivel, 1/2" x 1/2" JIC Male (8-3, 10-2)	1
10	8.706-925.0	Bushing, 3/4" x 1/2" Pipe	1	29	9.802-040.0	Elbow, 1/2" JIC x 1/2", 90°	1
11	8.707-256.0	Pump Protector, 1/2" PTP	1	30	9.802-730.0	Bolt, 3/8" x 2 1/2", GR5 Zinc	2
12	8.706-297.0	Bushing, 3/8" x 1/4", Galv.	1		8.725-394.0	▲ Washer, 3/8" Flat	2
13	8.706-207.0	Elbow, 3/8" Street	1		8.725-395.0	▲ Nut, 3/8" ESNA	2
14	8.706-294.0	Bushing, 1/2" x 3/8"	1	31	8.706-992.0	Adapter, 1/2" x 3/8" (8-3 Auto Start Option)	1
15	6.390-126.0	Clamp, Hose, .46 -, .54 ST	1			▲ Not Shown	
16	9.802-870.0	Block, Unloader, 3/8" x 3/8", 1.25 Steel (8-3 Auto Start Option)	1				
	9.802-869.0	Block, Unloader, 1/2" x 1/2" x 1.75" Steel	1				
17	8.715-508.0	Unloader, VBXL 13 GPM, @3000 PSI (8-3, 10-2)	1				
	9.802-362.0	Unloader, PA 8 GPM @3650 PSI VB8 w/Switch (8-3 Auto Start Option)	1				
18	8.933-006.0	Switch, Flow, MV60, Yellow	1				
19	9.802-024.0	Elbow, 3/8" x 1/2" Steel, Street	1				
	8.706-168.0	Elbow, 3/8" Male Pipe (Auto Start Option)	1				

## VNGL FLOAT TANK EXPLODED VIEW

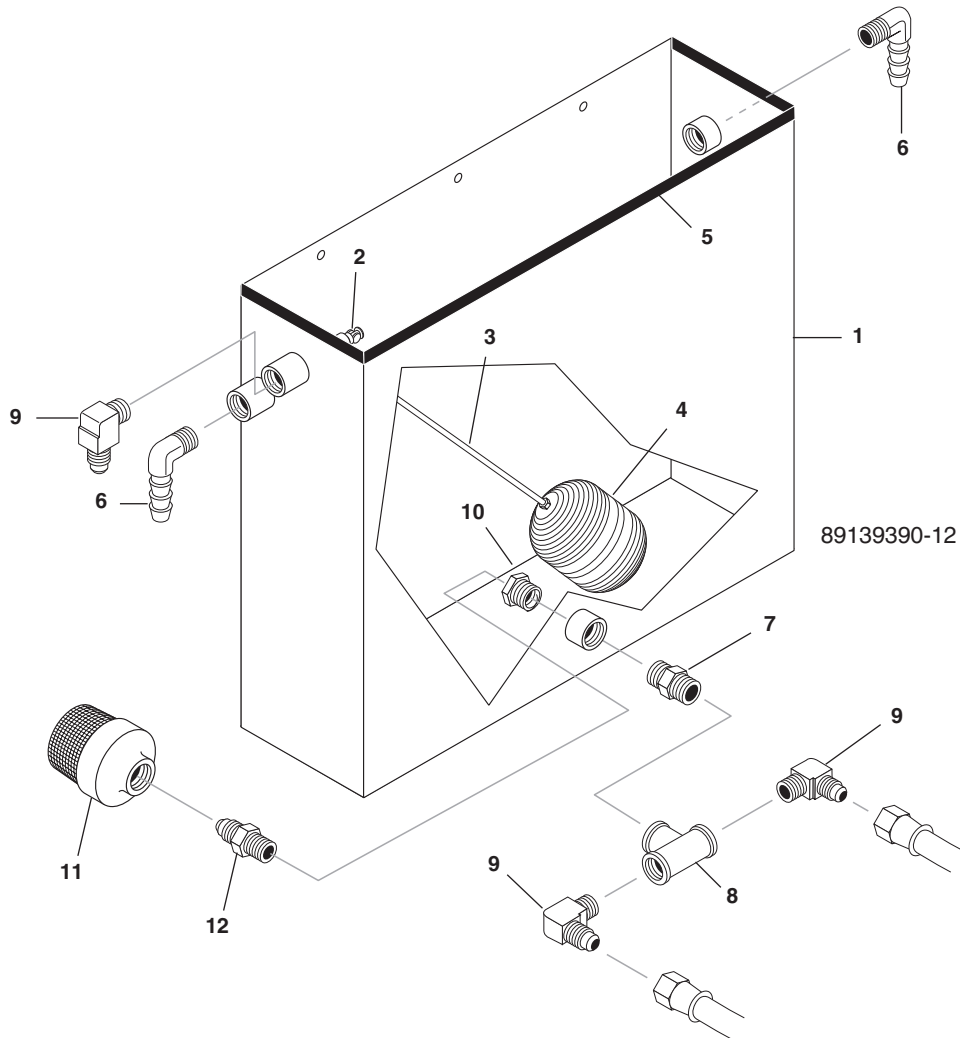

### VNGL FLOAT TANK (89035900) PARTS LIST

ITEM	PART NO.	DESCRIPTION	QTY	ITEM	PART NO.	DESCRIPTION	QTY
1	8.912-518.0	Assembly, Float Tank, S.S.	1	7	8.706-800.0	Nipple, 3/4" Hex, Brass	1
2	8.749-329.0	Valve, Float, 3/4"	1	8	8.706-846.0	Tee, 3/4" Female Pipe	1
3	8.707-025.0	Stem, 10" Float	1	9	9.803-557.0	Elbow, 3/4" SAE x 3/4", 90°, Brass	3
4	8.706-512.0	Ball, Float, Black Plastic	1	10	8.706-925.0	Bushing, 3/4" x 1/2" Pipe	1
5	9.802-071.0	Trim, 750 B2 x 1/16" Black	3.25 ft.	11	8.707-061.0	Strainer, 1/2" Basket	1
6	9.802-050.0	Adapter, 3/4" x 3/4" MT x Insert 90°	2	12	9.802-128.0	Nipple, 1/2" JIC x 1/2" Pipe	1

# HOSE & SPRAY GUN ASSEMBLY

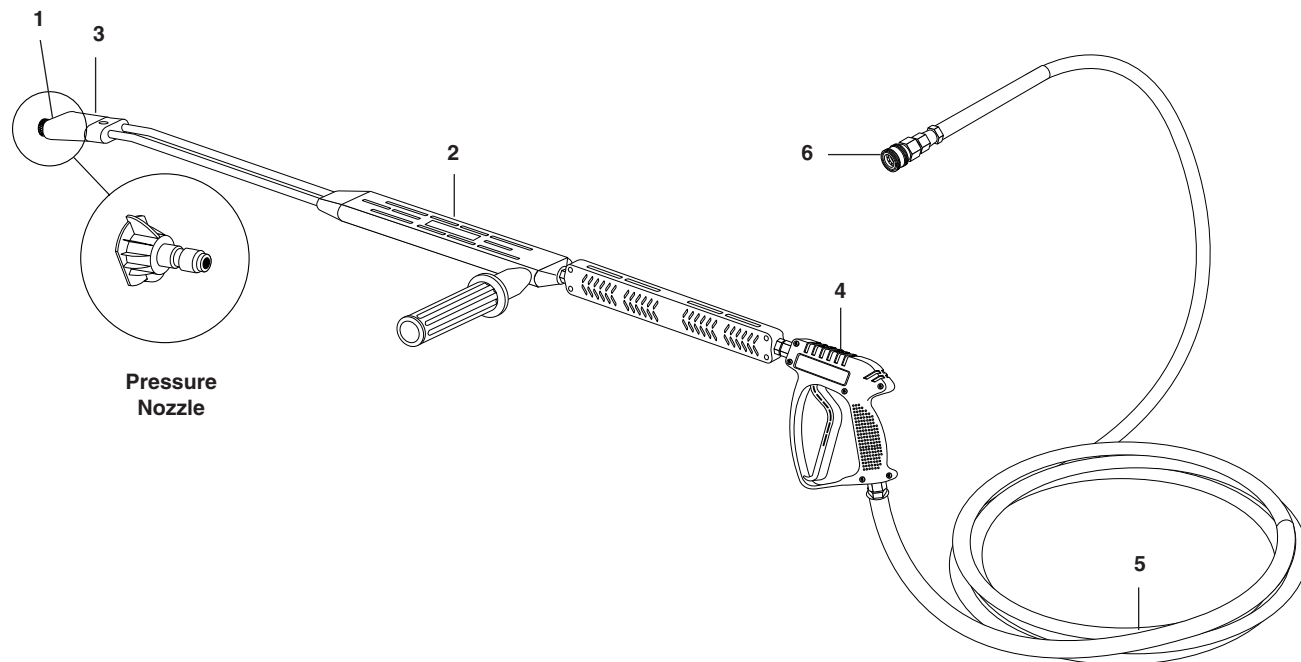

## HOSE & SPRAY GUN ASSEMBLY PARTS LIST

ITEM	PART NO.	DESCRIPTION	QTY	ITEM	PART NO.	DESCRIPTION	QTY
1	9.802-165.0	Coupler, 1/4", Male	1	4	8.751-234.0	Gun, Landa, L1050, 5000 PSI, 10.4 GPM	1
	9.802-096.0	▲ O-Ring, Small Coupler, High Heat, 1/4"	1	5	8.739-072.0	Hose, 3/8" x 50', 2-Wire Tuff-Skin (4-2, 4-3, 6-3)	1
2	8.711-308.0	Wand, SS, V.P. Wand, AR (AL 344) w/Coupler	1		8.739-401.0	Hose, 1/2" x 50' 2-Wire Tuff-Flex (8-3, 10-2)	1
	8.710-722.0	Wand Only, SS.V.P. Wand, AR (AL 344)	1	6	9.802-166.0	Coupler, 3/8" Female	1
		AL83455VPKIT Repair Kit, AR SS Seat (AL 334, 344)	1		9.802-100.0	▲ O-Ring, Large, Coupler, High Heat, 3/8"	1
3	9.802-286.0	Nozzle Only, 1/8"	1			▲ Not Shown	

## SPECIFICATIONS

### PARTS SPECIFICATIONS: LANDA PUMP

Machine Model	Pump Model	Part #	Pulley	Pulley Part #	Bushing	Bushing Part #	Size	Voltage/PH	Motor Part #	Pulley	Pulley Part #	Bushing
4-20024A	LT5030	8.904-874.0	2AK84H	9.802-375.0	25mm	9.802-403.0	6 HP	230V/1PH	9.802-336.0	2AK41H	8.715-545.0	1-1/8"
4-20024B	LT5030	8.904-874.0	2AK84H	9.802-375.0	25mm	9.802-403.0	6 HP	230V/3PH	8.751-004.0	2AK41H	8.715-545.0	1-1/8"
4-20024C	LT5030	8.904-874.0	2AK84H	9.802-375.0	25mm	9.802-403.0	6 HP	460V/3PH	8.751-004.0	2AK41H	8.715-545.0	1-1/8"
4-20024H	LT5030	8.904-874.0	2AK84H	9.802-375.0	25mm	9.802-403.0	6 HP	208V/3PH	9.802-330.0	2AK41H	8.715-545.0	1-1/8"
4-30024A	LT5030	8.904-874.0	2BK80H	8.715-592.0	25mm	9.802-403.0	8 HP	230V/1PH	8.715-165.0	2BK34H	9.802-382.0	1-3/8"
4-30024B	LT5030	8.904-874.0	2BK80H	8.715-592.0	25mm	9.802-403.0	8 HP	230V/3PH	8.750-999.0	2BK34H	9.802-382.0	1-3/8"
4-30024C	LT5030	8.904-874.0	2BK80H	8.715-592.0	25mm	9.802-403.0	8 HP	460V/3PH	8.750-999.0	2BK34H	9.802-382.0	1-3/8"
4-30024H	LT5030	8.904-874.0	2BK80H	8.715-592.0	25mm	9.802-403.0	8 HP	208V/3PH	8.750-998.0	2BK34H	9.802-382.0	1-3/8"
6-30024B	LT6035/L	8.904-883.0	3BK70H	8.715-617.0	25mm	9.802-403.0	15 HP	230V/3PH	8.751-006.0	3TB56	8.715-606.0	P1x1-5/8"
6-30024C	LT6035/L	8.904-883.0	3BK70H	8.715-617.0	25mm	9.802-403.0	15 HP	460V/3PH	8.751-006.0	3TB56	8.715-606.0	P1x1-5/8"
8-30024B	LX9536	8.920-590.0	3BK80H	8.715-618.0	25mm	9.802-403.0	20 HP	230V/3PH	8.751-012.0	3TB60	8.715-607.0	P1x1-5/8"
8-30024C	LX9536	8.920-590.0	3BK80H	8.715-618.0	25mm	9.802-403.0	20 HP	230V/3PH	8.751-012.0	3TB60	8.715-607.0	P1x1-5/8"
8-30024H	LX9536	8.920-590.0	3BK80H	8.715-618.0	25mm	9.802-403.0	20 HP	208V/3PH	8.715-125.0	3TB60	8.715-607.0	P1x1-5/8"
10-20024B	LX1036	8.920-592.0	3BK70H	8.715-617.0	25mm	9.802-403.0	20 HP	230V/3PH	8.751-012.0	3TB60	8.715-607.0	P1x1-5/8"
10-20024C	LX1036	8.920-592.0	3BK70H	8.715-617.0	25mm	9.802-403.0	20 HP	460V/3PH	8.751-012.0	3TB60	8.715-607.0	P1x1-5/8"

# SPECIFICATIONS

## PARTS SPECIFICATIONS: LANDA PUMP (CON'T)

Model (Con't)	Bushing Part #	Belt Size/Qty	Belt Part #	Motor Contact	Motor Overload	Stepdown Transformer	Primary Fuse	Primary Fuse Part #	Secondary Fuse	Secondary Fuse Part #	Stepdown Transformer
4-2A	9.802-400.0	AX37 (2)	9.802-409.0	8.724-281.0	N/A	9.802-552.0	1 A	8.933-007.0 (2)	8/10 A	9.802-464.0	9.802-553.0
4-2B	9.802-400.0	AX37 (2)	9.802-409.0	8.724-272.0	8.724-304.0	9.802-552.0	1 A	8.933-007.0 (2)	8/10 A	9.802-464.0	9.802-553.0
4-2C	9.802-400.0	AX37 (2)	9.802-409.0	8.724-268.0	8.724-303.0	9.802-552.0	1/2 A	9.802-462.0 (2)	8/10 A	9.802-464.0	9.802-553.0
4-2H	9.802-400.0	AX37 (2)	9.802-409.0	8.724-276.0	8.724-304.0	8.716-882.0	1 A	8.933-007.0 (2)	8/10 A	9.802-464.0	9.802-553.0
4-3A	9.802-401.0	BX34 (2)	8.715-695.0	8.724-281.0	8.724-306.0	9.802-552.0	1 A	8.933-007.0 (2)	8/10 A	9.802-464.0	9.802-553.0
4-3B	9.802-401.0	BX34 (2)	8.715-695.0	8.724-276.0	8.724-305.0	9.802-552.0	1 A	8.933-007.0 (2)	8/10 A	9.802-464.0	9.802-553.0
4-3C	9.802-401.0	BX34 (2)	8.715-695.0	8.724-268.0	8.724-304.0	9.802-552.0	1/2 A	9.802-462.0 (2)	8/10 A	9.802-464.0	9.802-553.0
4-3H	9.802-401.0	BX34 (2)	8.715-695.0	8.724-276.0	8.724-305.0	8.716-882.0	1 A	8.933-007.0 (2)	8/10 A	9.802-464.0	9.802-553.0
6-3B	9.803-980.0	BX50 (3)	8.715-709.0	8.724-281.0	8.724-307.0	9.802-552.0	1 A	8.933-007.0 (2)	8/10 A	9.802-464.0	9.802-553.0
6-3C	9.803-980.0	BX50 (3)	8.715-709.0	8.724-276.0	8.724-304.0	9.802-552.0	1/2 A	9.802-462.0 (2)	8/10 A	9.802-464.0	9.802-553.0
8-3B	9.803-980.0	BX54 (3)	8.715-712.0	8.735-015.0	8.724-307.0	9.802-552.0	1 A	8.933-007.0 (2)	8/10 A	9.802-464.0	9.802-553.0
8-3C	9.803-980.0	BX54 (3)	8.715-712.0	8.724-281.0	8.724-305.0	9.802-552.0	1/2 A	9.802-462.0 (2)	8/10 A	9.802-464.0	9.802-553.0
8-3H	9.803-980.0	BX54 (3)	8.715-712.0	8.735-015.0	8.724-307.0	8.716-882.0	1 A	8.933-007.0 (2)	8/10 A	9.802-464.0	9.802-553.0
10-2B	9.803-980.0	BX52 (3)	8.715-711.0	8.735-015.0	8.724-307.0	9.802-552.0	1 A	8.933-007.0 (2)	8/10 A	9.802-464.0	9.802-553.0
10-2C	9.803-980.0	BX52 (3)	8.715-711.0	8.724-281.0	8.724-306.0	9.802-552.0	1/2 A	9.802-462.0 (2)	8/10 A	9.802-464.0	9.802-553.0

**PRESSURE WASHER Specifications**

## BURNER SPECIFICATIONS

MODEL	BURNER ASSEMBLY	JET SIZE	GAS VALVE	PILOT ORIFICE CONVERSION
VNG4-2000	X-44	#54	3/4" VB8304	No
VNG4-3000	X-44	#54	3/4" VB8304	No
VNG6-3000	SQ-98	#54	1" V8943B	No
VNG8-3000	SQ-98	#54	1" V8943B	No
VNG10-2000	SQ-98	#54	1" V8943B	No
VLP4-2000	X-44	#63	3/4" V8943B-393691 LP Kit	No
VLP4-3000	X-44	#63	3/4" V8943B-393691 LP Kit	No
VLP6-3000	SQ-98	#65	1" V8943C	No
VLP8-3000	SQ-98	#65	1" V8943C	No
VLP10-2000	SQ-98	#65	1" V8943C	No

## BASIC FACTS

BASED ON 60° F	PROPANE	BUTANE
Formula	C3H8	C4H10
Vaporization Point (°F)	-43.7	31.1
Specific Gravity (Vapor)	1.522	2.006
Specific Gravity (Liquid)	0.508	0.584
Lbs. Per Gallon (Liquid)	4.23	4.87
B.T.U. Per Cubic Foot (Vapor)	2.563	3.39
B.T.U. Per Lb. (Vapor)	21.663	21/3-9
B.T.U. Per Gallon (Liquid)	91.74	1-3/93
Cubic Feet Per Lb. (Liquid)	8.607	7/53
Cubic Feet Per Gallon (Liquid)	3.45	31/9
Octane Number	125	1
Molecular Weight	44.09	58.12
To calculate running cost:		
1 cubic Ft./1,000 B.T.U.		
100 cubic Ft./Therm		
Therm/Hour		
50¢ Therm		
Example:	Using natural gas	
	400,000 BTU Machine	
	400 cubic feet	
	4 Therms/hour	
	4 x .50 = \$2.00/hour to run	

## PRESSURE EQUIVALENTS

Simply stated, pressure is the force exerted by a gas or liquid attempting to escape from a container. It is useful to know how strong this “attempt to escape” is. Pressure can be measured with a manometer or with a pressure gauge. At the lower levels, it is expressed in “water column inches” i.e. 1 w.c.i. Higher pressures are expressed in terms of the force exerted against a square inch of area. For example, 125 lbs. per square inch (125 psi).

1 Water Column Inch	=	50 Oz./Sq. In.	11 Water Column Inches	=	6.35 Oz./Sq. In.
11 Water Column Inches	=	4 Lb./Sq. In.	1 Lb./Sq. In.	=	27.71 Water Column Inches
1 Lb./Sq. In.	=	"2.04" Mercury"	"1" Mercury"	=	.39 Lb./Sq. In.
1 Std. Atmosphere	=	14.73 Lbs./Sq. In.			

# VRT3 UNLOADER EXPLODED VIEW AND PARTS LIST

8.750-297.0, 8 GPM, 2320 PSI  
 8.750-298.0, 8 GPM, 3630 PSI  
 8.750-299.0, 8 GPM, 4500 PSI

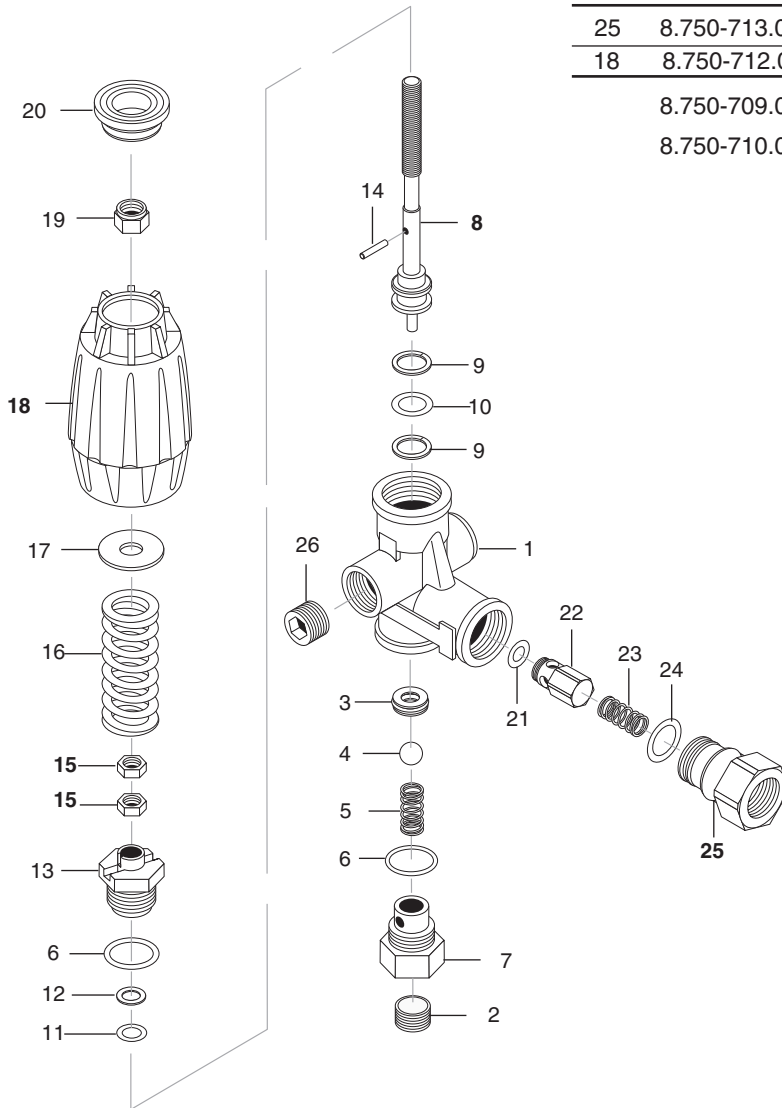

ITEM	PART NO.	DESCRIPTION	QTY
25	8.750-713.0	Outlet Fitting	1
18	8.750-712.0	Knob, Unloader	1
	8.750-709.0	Repair Kit, VRT3, 2320/3630 PSI	
	8.750-710.0	Repair Kit, VRT3, 4500 PSI	
(Kit Items: 3, 4, 6, 9-12, 21, 24)			

## Unloader Adjustment Procedures

1. Remove lock nut (Item 19).
2. Remove adjustment knob (Item 18).
3. Loosen the two (2) nuts (Item 15), move them upward on stem (Item 8) until you see 4 or more threads below the nut.
4. Re-attach adjusting knob (Item 18).
5. Start machine. Open the trigger of the spray gun. Increase pressure by turning adjustment knob (Item 18) clockwise until pressure is at the desired operating pressure.
6. Remove the adjustment knob (Item 18), tighten the lower nut (Item 15) tightly against the upper nut (Item 15). Re-attach adjustment knob (Item 18) and screw down until contact is made with the nuts (Items 15). Screw down lock nut (Item 19) onto the stem (Item 8) until the threads cut into the nylon insert of the lock nut (Item 19).

\*If adjustment knob (Item 18) **DOES NOT** make contact with upper nut (Items 15), remove adjusting knob (Item 18), re-adjust (raise) nuts (Items 15) on stem (Item 8) and re-attach adjustment knob (Item 18), then repeat step #6.

\*\*If adjustment knob (Item 18) **DOES** make contact with upper nut; release the trigger of the spray gun and watch the pressure gauge for the pressure increase ("spike"). This "spike" **SHOULD NOT** exceed 500 psi above the operating pressure. If "spike" pressure exceeds the 500 psi limit, remove the adjusting knob (Item 18) and re-adjust (lower) the nuts (Items 15) on the stem (Item 8). Re-attach the adjusting knob (Item 18), then repeat step #6.

# VBXL 8.715-508.0 (5-3324) UNLOADER EXPLODED VIEW

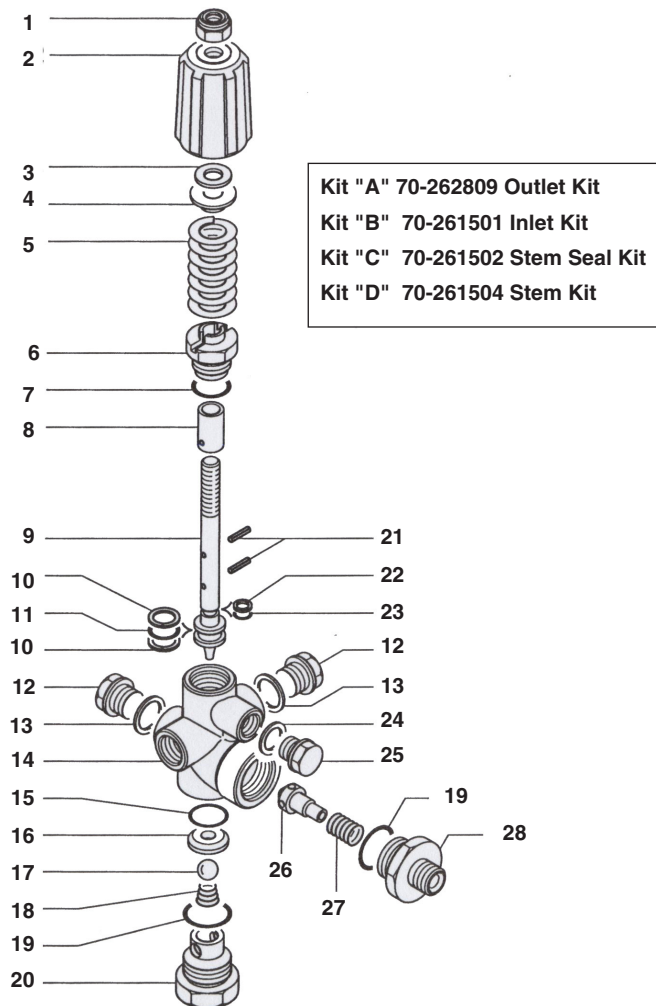

## VBXL 5-3324 UNLOADER EXPLODED VIEW PARTS LIST

ITEM#	PART #	DESCRIPTION	KIT	QTY	ITEM#	PART #	DESCRIPTION	KIT	QTY
1	8.717-192.0	Nut, Locking		1	15	9.803-948.0	O-Ring, Seat	B	1
2	8.717-269.0	Handle, Red		1	16	8.932-703.0	Seat	B	1
3	8.932-697.0	Space, Anti-friction	D	1	17	8.730-888.0	Ball, 7/16"	B	1
4	8.932-693.0	Plate	D	1	18	8.730-688.0	Spring, Ball	B	1
5	8.932-689.0	Spring	D	1	19	8.932-681.0	O-Ring, Relief	A,B	2
6	8.717-403.0	Stem Nut	D	1	20	8.717-405.0	Relief, 1/2"		1
7	9.803-191.0	O-Ring, Nut	C	1	21	8.932-705.0	Pin	C	2
8	8.932-684.0	Spacer, Red		1	22	8.717-077.0	O-Ring, Teflon 106	C	1
9	8.932-695.0	Stem	D	1	23	8.932.702.0	O-Ring, Stem	C	1
10	8.717-078.0	O-Ring, Teflon 115	C	2	24	9.803-198.0	Washer, Copper		1
11	8.932-682.0	O-Ring, Stem	C	1	25	9.803-951.0	Plug, 1/4"		1
12	9.802-925.0	Plug, 3/8"		2	26	9.803-917.0	Poppet	A	1
13	9.803-198.0	Washer, Copper, 3/8"		3	27	8.933-017.0	Spring, Poppet	A	1
	9.803-950.0	Washer, Copper, 1/4"		1	28	8.932-701.0	Discharge Port, 1/2"		1
14	8.932-679.0	Body		1	29	8.932-702.0	Connector		1

## VB8 VALVE EXPLODED VIEW

### VB8 Valve, 9.802-362.0 (5-3027)

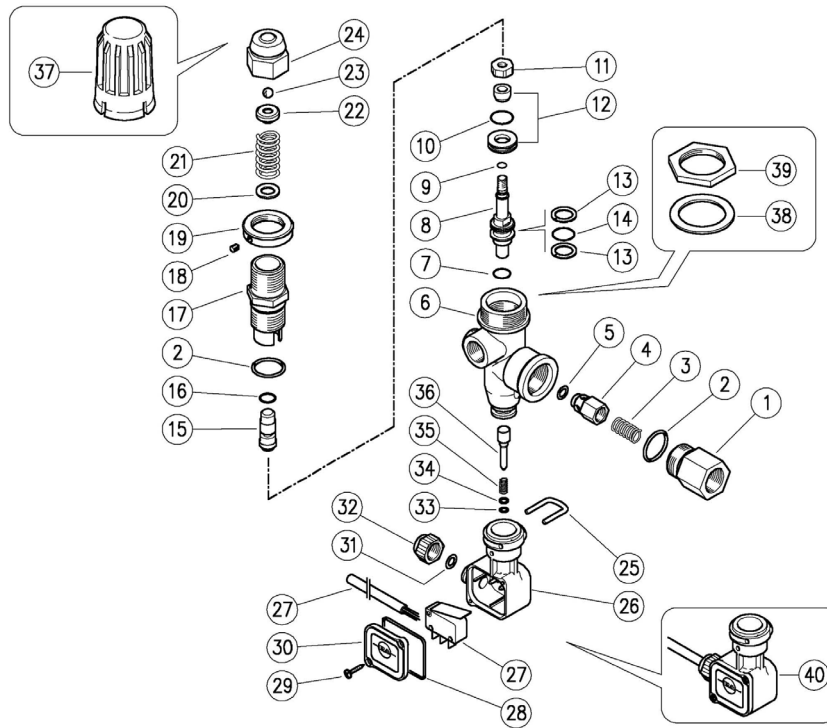

## VB8 VALVE EXPLODED VIEW PARTS LIST

ITEM#	PART #	DESCRIPTION	QTY	ITEM#	PART #	DESCRIPTION	QTY
1	60.0058.31	Delivery coupl., 3/8F Bsp brass	1	22	60.1210.31	Spring guiding ring	1
2	10.3070.02	O-Ring 1.78 x 18.77 mm Ni 85	2	23	14.7421.50	Ball, 1/4" Sst.	1
3	60.0053.51	Spring, 0.7 x 9 x 20 mm Sst.	1	24	60.1209.31	Valve regulating Insert, brass	1
4	60.0052.31	Shutter pin, brass	1	25	29.0087.51	U-bolt, Sst.	1
5	10.3070.02	O-Ring, 3 x 6 mm	1	26	29.0089.84	Housing, PR5 PA black	2
6	60.1201.35	Housing-BB8, 3/8 M Bsp c/sunk, brass	1	27	12.5006.00	Cable, 3 x 0.75L.1000 mm + Microswitch	1
7	10.3170.08	O-Ring, 2.62 x 7.6 mm Ni 85	1	28	10.3206.01	O-Ring, 2.62 x 28.25 mm	1
8	60.1206.31	Piston, M6 brass	1	29	16.3020.00	S/tapp. screw, DIN7981 2.5 x 12mm nick.pl.	2
9	10.3001.01	O-Ring, 1 x 4 mm Ni 85	1	30	29.0088.84	Lid, PR5 PA black	1
10	10.3066.01	O-Ring, 1.78 x 15.6 mm Ni 85	1	31	10.3169.00	O-Ring, 2.62 x 6.02 mm	1
11	60.1205.31	Special Nut, M6 brass	1	32	29.0082.84	Locknut for cable gland, PA black	1
12	60.2221.20	Seat, 10 mm + O-Ring, 1.78 mm NBR 85+shutt.	1	33	10.3038.00	O-Ring, 1.78 x 3.68 mm	1
13	10.4021.00	Back-up Ring, opn. 11.5 x 15.9 x 1.2 mm	2	34	14.3519.53	Washer, 4 x 8 x 0.8 mm Sst.	1
14	10.3175.00	O-Ring 2.65 x 10.77 mm	1	35	60.2303.51	Spring, 1.1 x 8 x 20 mm Sst.	1
15	60.1204.31	Spring rest pin, brass	1	36	60.1281.31	Micro-switch piston, brass	1
16	10.3167.01	O-Ring, 2.62 x 5.23 mm Ni 85	1	37	60.1202.84	Valve regulating knob, PA black (1)	1
17	60.1203.31	Piston holder, brass	1	38	14.3582.00	Washer, 30.5 x 42 x 2 mm	1
18	16.2100.00	Set screw, DIN914M 4 x 4 mm	1	39	60.2254.31	Ring nut , M30 brass (1)	1
19	60.1704.31	Ring nut, M22 x 1 brass	1	40	29.0096.24	Casing kit - PR5, complete 40 bar	1
20	14.3719.00	Washer, 9 x 15 x 1, 5 mm Sst.	1				
21	60.1208.61	Spring, 3.2 x 15.4 x 33 mm z.pl.	1				
				Kit: K1	60.1212.24	Repair kit-VB8. 9 x 1 pcs. (1) 60.1290.00	1

## VB8 VALVE EXPLODED VIEW PARTS LIST

ITEM	PART NO.	DESCRIPTION	QTY	ITEM	PART NO.	DESCRIPTION	QTY
1	12-60005831	3/8" Bsp F Outlet Fitting	1	21	12-60120861	Spring 3 x 33mm	1
2	12-10307002	‡ O-Ring 1.78 x 18.77mm	2	22	12-60121031	Upper Frame	1
3	12-60005351	Spring	1	23	12-14742100	1/4" Ball	1
4	12-60005231	Check Valve	1	24	12-60120931	Brass Cap	1
5	12-10321300	‡ O-Ring 3 x 6mm	1	25	12-29008751	Sst Clip	1
6	12-60120135	VB8 Brass Body	1	26	12-29008984	Plastic Housing	1
7	12-10317008	‡ O-Ring 2.62 x 7.6	1	27	12-12500600	El. Cable & Micro Switch	1
8	12-60120631	Piston	1	28	12-10320601	O-Ring 2.62 x 28.25mm	1
9	12-10300101	‡ O-Ring 1 x 4mm	1	29	12-16302000	2.5 x 12mm Screw	2
10	12-10306601	‡ O-Ring 1.78 x 15.6mm	1	30	12-29008884	Cover	1
11	12-60120531	M6 Nut	1	31	12-10316900	O-Ring 2.62 x 6.02mm	1
12	12-60222120	‡ VB8 Seat & Shutter	1	32	12-29008284	Black Nut - 40 Bar	1
13	12-10402100	‡ Back Ring 11.4 x 15.9	2	33	12-10303800	O-Ring 1.78 x 3.68	1
14	12-10317500	‡ O-Ring 2.62 x 10.77mm	1	34	12-14351900	Washer 4 x 8mm	1
15	12-60120431	Spring Guide	1	35	12-60230351	Spring	1
16	12-10316701	‡ O-Ring 2.62 x 5.23mm	1	36	12-60128131	PR 5 Pin	1
17	12-60120331	Piston Housing	1	37	12-60120284	Plastic Handle (83-60129000)	1
18	12-16210000	M4 x 4mm Dowel	1	38	12-14358200	Washer D. 30mm (8360129000)	1
19	12-60170431	M22 Nut	1	39	12-60225431	M30 Nut (83-60129000)	1
20	12-14371900	Washer 9 x 15mm	1	40	12-29009624	PR5 Pl. Housing Kit	1
					12-60121224	‡ VB8 Repair Kit	

## LT.1 SERIES PUMP EXPLODED VIEW

- 8.904-869.0 LT4035.1 Right
- 8.904-870.0 LT4035.1 Left
- 8.904-871.0 LT4040.1 Right
- 8.904-872.0 LT4040.1 Left
- 8.904-874.0 LT5030.1 Right
- 8.904-879.0 LT5030.1 Left
- 8.904-881.0 LT6035.1 Right
- 8.904-883.0 LT6035.1 Left

# G3 Evolution

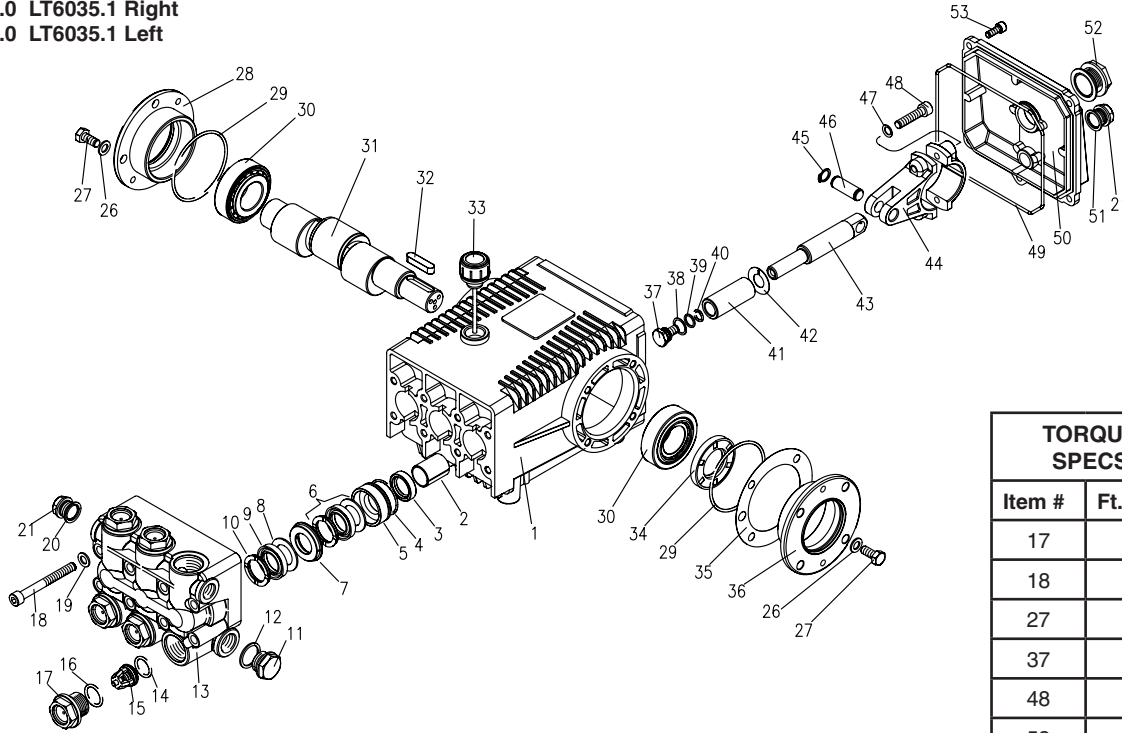

TORQUE SPECS	
Item #	Ft.-Lbs.
17	75
18	45
27	18
37	10
48	30
53	7.6

## LT.1 SERIES PUMP EXPLODED VIEW PARTS LIST

ITEM	PART NO.	DESCRIPTION	QTY	ITEM	PART NO.	DESCRIPTION	QTY
1	9.803-163.0	Crankcase	1	19	9.802-890.0	Washer	8
2	9.803-195.0	Plunger Guide	3	20	9.803-198.0	Copper Washer 3/8"	1
3*	See Kit	Plunger Oil Seal	3	21	9.802-925.0	Brass Plug 3/8"	1
4*	See Kit	O-Ring Ø1.78 x 31. 47	3	26	9.802-884.0	Washer	8
5*	See Kit	"Pressure Ring, Brass	3	27	9.802-944.0	Hexagonal Screw	8
6*	See Kit	"U" Seal Low Pressure	3	28	9.803-182.0	Closed Bearing Housing	1
7*	See Kit	Intermediate Ring, Brass	3	29	9.803-186.0	O-Ring Ø2.62 x 71.12	2
8*	See Kit	Support Ring, Teflon Bronze	3	30	9.803-160.0	Roller Bearing, Tapered	2
9 *	See Kit	"U" Seal High Pressure	3	31	9.803-148.0	Crankshaft (GT4040.1, 5030.1, 6035.1)	1
10*	See Kit	Support Ring	3		9.803-149.0	Crankshaft (GT 4035.1)	1
11	9.802-926.0	Brass Plug, 1/2"	1	32	9.803-167.0	Crankshaft Key	1
12	9.803-199.0	Copper Washer 1/2"	1	33	9.802-923.0	Oil Dip Stick	1
13	9.802-933.0	Manifold Head	1	34	9.803-139.0	Crankshaft Seal	1
14*	See Kit	O-Ring Ø2.62 x 17.13	6	35	9.803-177.0	Shim	2
15*	See Kit	Valve Assembly	6	36	9.803-181.0	Bearing Housing	1
16*	See Kit	O-Ring Ø2.62 x 20.29	6	37*	See Kit	Plunger Bolt	3
17	9.802-928.0	Valve Plug	6	38*	See Kit	Copper Spacer	3
18	9.802-943.0	Manifold Stud Bolt	8				

## LT.1 SERIES PUMP PARTS LIST (CONT)

ITEM	PART NO.	DESCRIPTION	QTY
39*	See Kit	O-Ring Ø1.78 x10.82	3
40*	See Kit	Teflon Ring	3
41*	See Kit	Plunger	3
42*	See Kit	Copper Spacer	3
43	9.803-143.0	Plunger Rod	3
44	9.803-157.0	Connecting Rod	3
45	9.802-912.0	Snap Ring	6
46	9.802-915.0	Connecting Rod Pin	3
47	9.802-889.0	Spring Washer	6
48	9.802-937.0	Connecting Rod Screw	6
49	9.803-194.0	O-Ring Ø2.62 x 152.07	1
50	9.803-166.0	Crankcase Cover	1
51	9.803-197.0	Gasket, G3/8	1
52	9.803-202.0	Sight Glass G3/4	1
53	9.802-939.0	Cover Screw	5

\* Part available in kit (See below)

REPAIR KIT NUMBER	8.916-488.0	8.916-487.0	8.916-322.0	8.916-323.0	9.802-607.0	9.802-611.0
KIT DESCRIPTION	Plunger "U" Seal 20mm LT-4040.1, LT-6035.1 LT-4035.1	Plunger "U" Seal 22mm LT-5030.1	"U" Seal Packing Assy 20mm LT-4040.1 LT-6035.1 LT-4035.1	"U" Seal Packing Assy 22mm LT-5030.1	Plunger 20mm LT-4040.1 LT-6035.1 LT-4035.1	Plunger 22mm LT-5030.1
ITEM NUMBERS INCLUDED	4, 6, 8, 9, 10	4, 6, 8, 9, 10	4, 5, 6, 7, 8, 9,10	4, 5, 6, 7, 8, 9,10	37, 38, 39, 40, 41, 42	37, 38, 39, 40, 41, 42
NUMBER OF CYLINDERS KIT WILL SERVICE	3	3	1	1	1	1

REPAIR KIT NUMBER	9.802-603.0	9.802-606.0
KIT DESCRIPTION	Complete Valve (all pumps)	Plunger Oil Seals (all pumps)
ITEM NUMBERS INCLUDED	14, 15, 16	3
NUMBER OF CYLINDERS KIT WILL SERVICE	6	3

## LX.2 PUMP SERIES EXPLODED VIEW

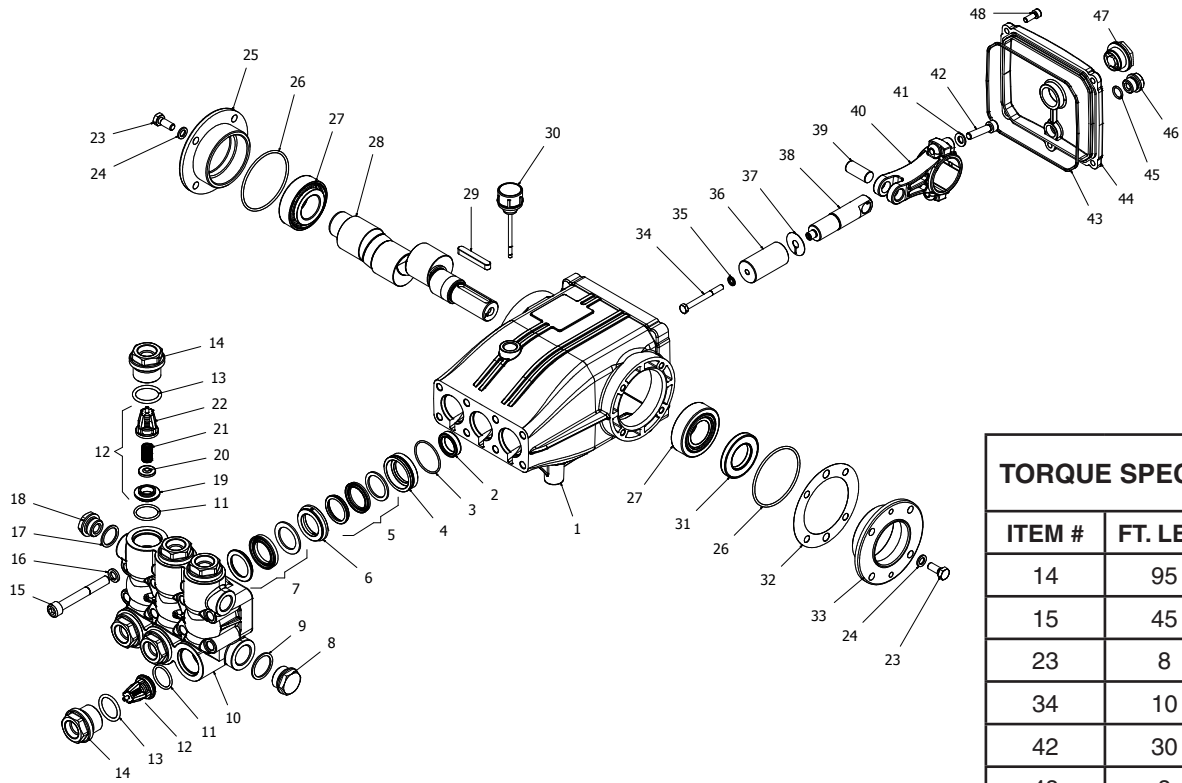

TORQUE SPECS	
ITEM #	FT. LBS.
14	95
15	45
23	8
34	10
42	30
48	8

## LX.2 PUMP SERIES EXPLODED VIEW PARTS LIST

ITEM	PART NO.	DESCRIPTION	QTY	ITEM	PART NO.	DESCRIPTION	QTY
1	8.752-825.0	Crankcase	1	18	9.802-926.0	Brass Plug 1/2	1
2*	See Kit Below	Plunger Oil Seal	3	19	See Kit Below	Valve Seat	6
3*	See Kit Below	O-Ring Ø1.78 x 37.82	3	20	See Kit Below	Valve Plate	6
4*	See Kit Below	Pressure Ring	3	21	See Kit Below	Valve Spring	6
5*	See Kit Below	U-Seal, 25mm	3	22	See Kit Below	Valve Cage	6
6*	See Kit Below	Intermediate Ring	3	23	8.752-830.0	Hex Screw	8
7*	See Kit Below	U-Seal	3	24	9.802-884.0	Washer	8
8*	9.803-285.0	Brass Plug, G3/4	1	25	9.803-182.0	Closed Bearing Housing	1
9	9.803-286.0	Copper Washer 3/4	1	26	9.803-186.0	O-Ring Ø2.62 x 71.12	2
10	8.752-831.0	Manifold Housing Ø22/Ø20/	1	27	9.803-160.0	Roller Bearing	2
11	8.752-836.0	O-Ring Ø2.62 x 21.89	6	28	8.752-829.0	Crankshaft Ø25 (9536)	1
12*	See Kit Below	Valve Assembly	6	28	8.752-827.0	Crankshaft Ø25 (1036)	1
13	9.803-287.0	O-Ring Ø3.53 x 25.80-134	6	29	9.803-293.0	Crankshaft Key	1
14	8.752-855.0	Valve Plug	6	30	8.752-834.0	Oil Dip Stick	1
15	8.752-833.0	Manifold Stud Bolt	8	31	9.803-139.0	Crankshaft Seal	1
16	9.802-890.0	Lock Washer8		32	9.803-177.0	Shim	2
17	9.803-199.0	Copper Washer 1/2	1				

## LX.2 PUMP SERIES EXPLODED VIEW PARTS LIST (CONT)

ITEM	PART NO.	DESCRIPTION	QTY
33	9.803-181.0	Bearing Housing	1
34*	8.752-841.0	Plunger Bolt	3
35*	8.752-820.0	Bonded Seal	3
36*	8.752-847.0	Plunger, 22mm	3
37*	8.752-823.0	Copper Spacer	3
38*	8.752-842.0	Plunger Rod	3
39*	8.752-822.0	Connecting Rod Pin	3
40	9.803-157.0	Connecting Rod	3
41*	9.802-889.0	Spring Washer	6
42*	9.802-937.0	Connecting Rod Screw	6
43	9.803-194.0	O-Ring Ø2.62 x 152.07	1
44	8.752-826.0	Crankcase Cover	1
45	9.803-906.0	O-Ring Ø1.78 x 14.00	1
46	8.707-262.0	Brass Plug G3/8	1
47	9.803-202.0	Sight Glass G3/4	1
48	8.752-824.0	Cover Screw	5

\* Part available in kit (See below)

KIT NUMBERS	8.752-844.0	8.752-850.0	8.752-839.0	8.753-349.0	8.752-835.0
KIT DESCRIPTION	Plunger Seals 22 mm	Seal Packing 22mm	Plunger 22mm	Complete Valve	Plunger Oil Seals
ITEMS NUMBERS INCLUDED	3, 5, 7	3, 4, 5, 6, 7,	34, 35, 36, 37	11, 12, 13	2
NUMBER OF CYLINDERS KIT WILL SERVICE	3	1	1	6	3





**LANDA LIMITED NEW PRODUCT WARRANTY  
PRESSURE WASHERS  
WHAT THIS WARRANTY COVERS**

All LANDA pressure washers are warranted by LANDA to the original purchaser to be free from defects in materials and workmanship under normal use, for the periods specified below. This Limited Warranty is subject to the exclusions shown below, is calculated from the date of the original purchase, and applies to the original components only. Any parts replaced under this warranty will assume the remainder of the part's warranty period.

**SEVEN YEAR PARTS AND ONE YEAR LABOR WARRANTY:**

Components manufactured by LANDA, such as frames, handles, top and bottom wraps, float tanks, fuel tanks, belt guards, and internal components on the oil-end of Landa manufactured pumps. Pro-Duty units (PD Series) have a three-year warranty against material defects and workmanship. General, AR, Legacy, Comet and swash and wobble plate pumps have a one year warranty. Heating coils have a five year warranty from date of original machine purchase.

**ONE YEAR PARTS AND ONE YEAR LABOR WARRANTY:**

All other components, excluding normal wear items as described below, will be warranted for one year on parts and labor. Parts and labor warranty on these parts will be for one year regardless of the duration of the original component manufacturer's part warranty.

**WARRANTY PROVIDED BY OTHER MANUFACTURERS:**

Motors, generators, and engines, which are warranted by their respective manufacturers, are serviced through these manufacturers' local authorized service centers. LANDA is not authorized and has no responsibility to provide warranty service for such components.

**WHAT THIS WARRANTY DOES NOT COVER**

This warranty does not cover the following items:

1. Normal wear items, such as nozzles, spray guns, discharge hoses, wands, quick couplers, seals, filters, gaskets, O-rings, packings, pistons, pump valve assemblies, strainers, belts, brushes, rupture disks, fuses, pump protectors.
2. Damage or malfunctions resulting from accidents, abuse, modifications, alterations, incorrect installation, improper servicing, failure to follow manufacturer's maintenance instructions, or use of the equipment beyond its stated usage specifications as contained in the operator's manual.
3. Damage due to freezing, chemical deterioration, scale build up, rust, corrosion, or thermal expansion.
4. Damage to components from fluctuations in electrical or water supply.
5. Normal maintenance service, including adjustments, fuel system cleaning, and clearing of obstructions.
6. Transportation to service center, field labor charges, or freight damage.

**WHAT YOU MUST DO TO OBTAIN WARRANTY SERVICE**

While not required for warranty service, we request that you register your LANDA pressure washer by returning the completed registration card. In order to obtain warranty service on items warranted by LANDA, you must return the product to your Authorized LANDA Dealer, freight prepaid, with proof of purchase, within the applicable warranty period. If the product is permanently installed, you must notify your Authorized LANDA Dealer of the defect. Your Authorized LANDA Dealer will file a claim with Landa, who must subsequently verify the defect. In most cases, the part must be returned to LANDA freight prepaid with the claim. For warranty service on components warranted by other manufacturers, your Authorized LANDA Dealer can help you obtain warranty service through these manufacturers' local authorized service centers.

**LIMITATION OF LIABILITY**

LANDA'S liability for special, incidental, or consequential damages is expressly disclaimed. In no event shall LANDA'S liability exceed the purchase price of the product in question. LANDA makes every effort to ensure that all illustrations and specifications are correct, however, these do not imply a warranty that the product is merchantable or fit for a particular purpose, or that the product will actually conform to the illustrations and specifications. Our obligation under this warranty is expressly limited at our option to the replacement or repair at a service facility or factory designated by us, of such part or parts as inspection shall disclose to have been defective. **THE WARRANTY CONTAINED HEREIN IS IN LIEU OF ALL OTHER WARRANTIES, EXPRESS OR IMPLIED, INCLUDING ANY IMPLIED WARRANTY OF MERCHANTABILITY OR FITNESS FOR A PARTICULAR PURPOSE ARE EXPRESSLY LIMITED TO THE DURATION OF THIS WRITTEN WARRANTY.** LANDA does not authorize any other party, including authorized LANDA Dealers, to make any representation or promise on behalf of LANDA, or to modify the terms, conditions, or limitations in any way. It is the buyer's responsibility to ensure that the installation and use of LANDA products conforms to local codes. While LANDA attempts to assure that its products meet national codes, it cannot be responsible for how the customer chooses to use or install the product. Some states do not allow limitations on how long an implied warranty lasts or the exclusion or limitation of incidental or consequential damages, so the above limitation or exclusion may not apply to you. This warranty gives you specific legal rights and you may also have other rights which vary from state to state.

**LANDA**

www.landa.com

**LANDA<sup>®</sup>**

Form #8.913-939.0 • Revised 4/13 • Printed in U.S.A