



Western Water Constructors, Inc.
Submittal Cover

Job no. 16-05



CONTRACT NAME: Manteca WQCF Digester Improvements
SPEC SECTION: 15521 Hot Water System Components
SUBMITTAL TITLE: Hot Water System Components - O&M
FILE NAME: 255-R0_15521-04_Hot Water System Components-OM

SUB #: 255
REV #: 0
CODE: 15521-04
DATE: 1/3/2018

WWC REVIEW/COMMENTS: [X] NO EXCEPTIONS [] EXCEPTIONS / DEVIATIONS AS NOTED

REVIEWED BY: ST

SIGNED: [Signature]

WWC HAS REVIEWED THIS SUBMITTAL FOR CONFORMANCE WITH THE PROJECT PLANS & SPECIFICATIONS.

OWNER REVIEW:

Table with columns: ITEM, DESCRIPTION, REVIEW STATUS (A, B, C, D, E). Rows include: 1 Chemical Bypass Feeder O&M, 2 Air Separator O&M, 3 Hot Water Boiler Loop Pumps O&M, 4 Hot Water Circulation Pumps O&M, 5 Hot Water System Primary Loop Pumps O&M.

LEGEND: A = No Exceptions Taken B = Make Correction Noted C = Correct & Resubmit
D = Rejected E = Accepted for Record

OWNER COMMENTS:

REVIEWER'S NAME: _____

REVIEWER'S SIGNATURE: _____

DATE: _____

EQUIPMENT SUMMARY FORM

1. EQUIPMENT ITEM Chemical Bypass Feeder
2. MANUFACTURER J.L Wingert
3. EQUIPMENT IDENTIFICATION NUMBER(S) DIG-TNK-07-437
(maps equipment number)
4. LOCATION OF EQUIPMENT Digester Control Building No. 2
5. WEIGHT OF INDIVIDUAL COMPONENTS (OVER 100 POUNDS) _____

6. NAMEPLATE DATA - Horsepower _____
Amperage _____
Voltage _____
Service Factor (S.F.) _____
Speed _____
ENC Type _____
Capacity _____
Other _____
7. MANUFACTURER'S LOCAL REPRESENTATIVE
Name Bay City Boiler
Address 23312 Cabot Blvd Hayward, CA 94545
Telephone Number 510-786-3711
8. MAINTENANCE REQUIREMENTS See O&M data

9. LUBRICANT LIST N/A

10. SPARE PARTS (recommendations) N/A

11. COMMENTS N/A

EQUIPMENT SUMMARY FORM

1. EQUIPMENT ITEM Air Separator
2. MANUFACTURER Armstrong Fluid Technology
3. EQUIPMENT IDENTIFICATION NUMBER(S) DIG-SEP-07-435
(maps equipment number)
4. LOCATION OF EQUIPMENT Digester Control Building No. 2
5. WEIGHT OF INDIVIDUAL COMPONENTS (OVER 100 POUNDS) _____
359 LBS
6. NAMEPLATE DATA - Horsepower _____
Amperage _____
Voltage _____
Service Factor (S.F.) _____
Speed _____
ENC Type _____
Capacity _____
Other _____
7. MANUFACTURER'S LOCAL REPRESENTATIVE
Name San Jose Boiler
Address 1585 Schallenberger Rd San Jose CA 95131
Telephone
Number 408-295-5235
8. MAINTENANCE REQUIREMENTS See O&M data
9. LUBRICANT LIST N/A
10. SPARE PARTS (recommendations) N/A
11. COMMENTS N/A

EQUIPMENT SUMMARY FORM

1. EQUIPMENT ITEM Hot Water Boiler Loop Pumps
2. MANUFACTURER Armstrong Fluid Technology
3. EQUIPMENT IDENTIFICATION NUMBER(S) PMP-012, PMP-022
(maps equipment number)
4. LOCATION OF EQUIPMENT Digester Control Building No. 2
5. WEIGHT OF INDIVIDUAL COMPONENTS (OVER 100 POUNDS) 526 lbs
6. NAMEPLATE DATA - Horsepower 3 HP
Amperage _____
Voltage 480 V
Service Factor (S.F.) 1.15
Speed 1177 RPM
ENC Type TEFC
Capacity _____
Other _____
7. MANUFACTURER'S LOCAL REPRESENTATIVE
Name San Jose Boiler
Address 1585 Schallenberger Rd San Jose CA 95131
Telephone Number 408-295-5235
8. MAINTENANCE REQUIREMENTS See O&M data
9. LUBRICANT LIST N/A
10. SPARE PARTS (recommendations) N/A
11. COMMENTS N/A

EQUIPMENT SUMMARY FORM

1. EQUIPMENT ITEM Hot Water Circulation Pumps
2. MANUFACTURER Armstrong Fluid Technology
3. EQUIPMENT IDENTIFICATION NUMBER(S) PMP-330, PMP-340, PMP-320, PMP-310
(maps equipment number)
4. LOCATION OF EQUIPMENT Digester Control Building No. 2
5. WEIGHT OF INDIVIDUAL COMPONENTS (OVER 100 POUNDS) _____
198 lbs
6. NAMEPLATE DATA - Horsepower 5 HP
Amperage _____
Voltage 480 V
Service Factor (S.F.) 1.15
Speed 3530 RPM
ENC Type TEFC
Capacity _____
Other _____
7. MANUFACTURER'S LOCAL REPRESENTATIVE
Name San Jose Boiler
Address 1585 Schallenberger Rd San Jose CA 95131
Telephone
Number 408-295-5235
8. MAINTENANCE REQUIREMENTS See O&M data
9. LUBRICANT LIST N/A
10. SPARE PARTS (recommendations) N/A
11. COMMENTS N/A

EQUIPMENT SUMMARY FORM

1. EQUIPMENT ITEM Hot Water System Primary Loop Pumps
2. MANUFACTURER Armstrong Fluid Technology
3. EQUIPMENT IDENTIFICATION NUMBER(S) PMP-410, PMP-420
(maps equipment number)
4. LOCATION OF EQUIPMENT Digester Control Building No. 2
5. WEIGHT OF INDIVIDUAL COMPONENTS (OVER 100 POUNDS) _____
294 lbs
6. NAMEPLATE DATA - Horsepower 5 HP
Amperage _____
Voltage 480 V
Service Factor (S.F.) 1.15
Speed 1200
ENC Type TEFC
Capacity _____
Other _____
7. MANUFACTURER'S LOCAL REPRESENTATIVE
Name San Jose Boiler
Address 1585 Schallenberger Rd San Jose CA 95131
Telephone
Number 408-295-5235
8. MAINTENANCE REQUIREMENTS See O&M data
9. LUBRICANT LIST N/A
10. SPARE PARTS (recommendations) N/A
11. COMMENTS N/A



BYPASS, FILTER & BROMINE FEEDERS

OPERATION & MAINTENANCE MANUAL



PLEASE RECORD THE FOLLOWING DATA

(Information is located on the product label or packing slip)

Model Number: _____

Service: _____

Code: _____

Installation Date: _____

Installation Location / Application: _____

The above information will help when ordering replacement parts and accessories for your Wingert Bypass Feeder.

J.L. WINGERT CO. MANUFACTURED PRODUCTS

Mixers, Bypass Feeders, Filter Feeders, Bromine Feeders, Sample Coolers, Sludge Traps, Separators, Separator Systems, Tank Stands, Tank Package Systems, Glycol Feed Systems, Coupon Racks, Control Stations, NEMA Enclosures, Custom Packaged Systems and Specialty Welding

CONTENTS:**PAGE**

| | | |
|------|--|------|
| 1.0 | INTRODUCTION | 2 |
| 2.0 | WARRANTY | 2 |
| 3.0 | UNPACKING | 2 |
| 4.0 | MODEL NUMBER VERIFICATION | 3-4 |
| 5.0 | LOCATION AND ENVIRONMENT | 4 |
| 6.0 | SAFETY | 5 |
| 6.1 | SAFETY HIGHLIGHTS | 5 |
| 7.0 | INSTALLATION | 5 |
| 7.1 | INSTALLATION DIAGRAM—BYPASS FEEDERS, PLEATED FILTER FEEDERS, HIGH PRESSURE FEEDERS, BROMINE FEEDERS & ASME | 6 |
| 7.2 | INSTALLATION DIAGRAM—FILTER (BAG) FEEDERS | 6 |
| 8.0 | APPLICATION INFORMATION & TROUBLESHOOTING | 7 |
| 9.0 | PVC VALVE PACKAGES | 7-8 |
| 10.0 | VALVE PACKAGE INSTRUCTIONS | 9 |
| 10.1 | UNPACKING | 9 |
| 10.2 | INSTALLATION | 9 |
| 11.0 | FILTER BAG INSTRUCTIONS | 9-10 |
| 11.0 | INSTALLATION | 10 |
| 12.0 | ACCESSORY ITEMS | 11 |
| 13.0 | MAINTENANCE | 11 |
| 14.0 | PARTS LISTING | 12 |

1.0 INTRODUCTION

J.L. Wingert Co. Feeders are designed to provide you with a rugged and reliable means of introducing chemicals into hot, chilled water or other liquids. Simplicity of design and ease of operation are inherent in every Wingert Feeder. The dual purpose Wingert Filter Feeder eliminates the need to install a separate bypass feeder and filter system saving time and money. Rugged reliability is engineered into our complete line of bypass, filter and bromine feeders which feature ease of installation and provide precise filtering capabilities down to 5 microns.

2.0 WARRANTY

Wingert Bypass, Filter & Bromine Feeders are warranted against manufacturing defects in material and workmanship for one year from the date of shipment. Applications outside the service for which the product is designed, including any non-factory modifications, will automatically void any warranty. Items returned to J.L. Wingert Co. for warranty consideration must be transported via prepaid freight. Final warranty determination will be made upon inspection. J.L. Wingert Co. will, at their discretion, repair or replace any defective item. Any repair or replacement outside warranted limitations will be considered a repair order and quoted accordingly. All replacements will be F.O.B. factory. There are no other implied or expressed warranties.

3.0 UNPACKING

Wingert Feeders are fully assembled and ready for installation. A feeder may be packed in a carton or shipped secured to a shipping pallet. Inspect packaging upon receipt for any damage. Unpack and inspect the product for damage and verify that goods received correlate with the packing list and product table on pages 3 and 4. Verify that no packing material has obstructed the inlet, outlet or purge openings. Notify the factory of any discrepancies immediately upon receipt. If any product is damaged due to freight handling, contact the factory immediately for further assistance. It is recommended that photo documentation of any damage or discrepancy be supplied to support any claims.

NOTE: Most freight carriers allow only a limited time after receipt of goods to file a freight claim.

4.0 MODEL NUMBER VERIFICATION

MODEL NUMBERING EXAMPLE

| FILTER TYPE- | STYLE- | CAPACITY | FILL CLOSURE | / OPTIONS |
|--------------|--------|----------|--------------|-----------|
| | | 5 | HD | /AR |
| | DB- | 2 | HD | /SL300 |
| F- | DB- | 2 | HD | /EK5 |
| FHC- | DB- | 12 | HD | /EK6 |
| PF- | | 5 | HD | /ARPG |



BYPASS FEEDERS AND FILTER FEEDERS Rated for 200 PSI @ 200°F

| FILTER TYPE | |
|-------------|--|
| | Non-filter feeder |
| F | Filter - Bag 2, 5 and 12 gallon only |
| FHC | Filter High Capacity - Bag 2, 5 and 12 gallon only |
| PF | Pleated filter - 2, 5 and 12 gallon only |

| STYLE | |
|-------|--|
| | Flat Bottom (no drain, no legs) - Standard Model Designation |
| DB | Dome Bottom (drain port and legs) |

| CAPACITY | |
|----------|--------------------|
| 2 | 2 gallon capacity |
| 5 | 5 gallon capacity |
| 12 | 12 gallon capacity |
| 18 | 18 gallon capacity |

| FILL CLOSURE | |
|--------------|---------------------------------------|
| HD | Heavy duty 3 1/2", 1/4 turn fill port |

| OPTIONS | |
|---------|---|
| EK1 | Epoxy coating inside only, 2 and 5 gallon sizes |
| EK2 | Epoxy coating inside and outside, 2 and 5 gallon sizes |
| EK3 | Epoxy coating outside only, 2 and 5 gallon sizes |
| EK4 | Epoxy coating inside only, 12 and 18 gallon sizes |
| EK5 | Epoxy coating inside and outside, 12 and 18 gallon sizes |
| EK6 | Epoxy coating outside only, 12 and 18 gallon sizes |
| AR | Air release, 1/4" valve assembly in top dome |
| ARPG | Air release / pressure gauge, 1/4" valve and 300PSI gauge assembly in top dome |
| PG | Pressure gauge, 300PSI gauge assembly in top dome |
| FBK | Filter bag kit (converts 2, 5, and 12 gallon Bypass Feeders into a Filter Feeder, non-filter feeder only) |
| SL125 | 125 PSI / 200° F (2 & 5 gallon models) |
| SL125B | 125 PSI / 200° F (12 gallon models) |
| SL125C | 125 PSI / 200° F (18 gallon models) |
| SL300 | 300 PSI / 200° F (2 & 5 gallon models) |
| SL300B | 300 PSI / 200° F (12 gallon models) |
| SL300C | 300 PSI / 200° F (18 gallon models) |

4.0 MODEL NUMBER VERIFICATION (CONTINUED)

HIGH PRESSURE BYPASS FEEDERS
Rated for 300 PSI @ 200° F

MODEL NUMBERING EXAMPLE

| STYLE- | CAPACITY- | MOUNT | /OPTIONS |
|--------|-----------|-------|----------|
| HP- | 5- | LEG | /AR |



| STYLE | |
|-------|------------------------------|
| HP | High pressure (1" FNPT fill) |

| CAPACITY | |
|----------|----------------------------------|
| 1 | 1 gallon capacity (without legs) |
| 2 | 2 gallon capacity (with legs) |
| 5 | 5 gallon capacity (with legs) |
| 12 | 12 gallon capacity (with legs) |

| OPTIONS | |
|---------|---|
| EK3 | Epoxy coating outside only, 2 and 5 gallon sizes |
| EK6 | Epoxy coating outside only, 12 and 18 gallon sizes |
| AR | Air release, 1/4" valve assembly in top dome |
| ARPG | Air release / pressure gauge, 1/4" valve 300 PSI gauge assembly in top dome |
| PG | Pressure gauge, 300 PSI gauge assembly in top dome |
| SL300 | 300 PSI / 200°F (2 & 5 gallon models) |
| SL300A | 300 PSI / 200°F (1 gallon models) |
| SL300B | 300 PSI / 200°F (12 gallon models) |
| ASME | Section VIII ASME Certified |

MODEL NUMBERING EXAMPLE

| MATERIAL- | STYLE- | CAPACITY | /OPTION |
|-----------|--------|----------|---------|
| FRP- | DB- | 2 | /ARPVC |



BROMINE (FIBERGLASS) BYPASS FEEDERS
Rated for 150 PSI @ 150° F

| MATERIAL | |
|----------|---|
| FRP | Glass filled polyester resin (fiberglass) |

| STYLE | |
|-------|---|
| | Flat Bottom (no drain port or stand) - Standard Model Designation |
| DB | Dome bottom (drain port and stand) |

| CAPACITY | |
|----------|--------------------|
| 2 | 2 gallon capacity |
| 5 | 5 gallon capacity |
| 12 | 12 gallon capacity |
| 16 | 16 gallon capacity |

| OPTION | |
|--------|--|
| ARPVC | PVC air release valve and installation tee |

5.0 LOCATION AND ENVIRONMENT

Wingert Feeders are designed for outdoor applications, however, exposure to extreme cold environment may freeze and expand contents causing vessel to burst. All feeders (except bromine) are coated with a water based enamel. Further protection may be added with one of the “-EK” epoxy coating options (except bromine feeders).

6.0 SAFETY

J.L. Wingert Co.'s equipment is designed and built with safety in mind. However, proper installation and operation can increase your overall safety.

DO NOT INSTALL, OPERATE OR REPAIR THIS EQUIPMENT WITHOUT READING THIS MANUAL AND THE SAFETY PRECAUTIONS CONTAINED THROUGHOUT. BE SURE THAT ALL INSTALLATION, OPERATION, MAINTENANCE AND REPAIR PROCEDURES ARE PERFORMED ONLY BY QUALIFIED INDIVIDUALS.

6.1 SAFETY HIGHLIGHTS

Read and understand the following safety highlights.

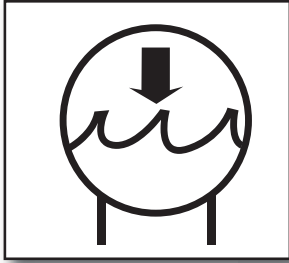

WATER PRESSURE INSIDE THE UNIT

See design specification for maximum operating pressure. Do not perform maintenance or repair without first releasing the water pressure and draining the fluid from the unit.



EQUIPMENT IDENTIFICATION LABEL

Identification label provides equipment information.

7.0 INSTALLATION

The following factors must be considered when installing your Wingert Feeder:

1. FLOWRATE

All Wingert Feeders are designed as bypass vessels and flow rate through feeder should not exceed:

- 1 GPM on 1 gallon feeders*
- 2 GPM on 2 gallon feeders*
- 5 GPM on 5 gallon feeders and larger*

2. PRESSURE DIFFERENTIAL

Pressure differential should not exceed 5 PSI on filtered feeders.

On all others, pressure differential should not exceed 10 PSI.

3. CREATING AND REGULATING FLOW AND PRESSURE DIFFERENTIAL

The key to any good installation is determining how you are going to create and control the flow rate and pressure differential. The most effective way to do this is to plumb the bypass line across the recirculation pump, or to install a throttling valve in the main line. Controlling the flow is most effective when using a flow control valve set at a factory preset flow rate. You may also use globe, gate or needle valves to achieve proper flow.

Use the following diagrams to decide which installation is the correct one for your application.

Consult your factory representative for variations in standard installations.

7.1 INSTALLATION DIAGRAM — BYPASS FEEDERS, PLEATED FILTER FEEDERS, HIGH PRESSURE FEEDERS, BROMINE FEEDERS & ASME
Bypass Feeders, Pleated Filter Feeders, High Pressure Feeders & Bromine Feeders use the lower side port for inlet and the upper side port for outlet.

See 7.2 for Bag Filter Feeder Installation

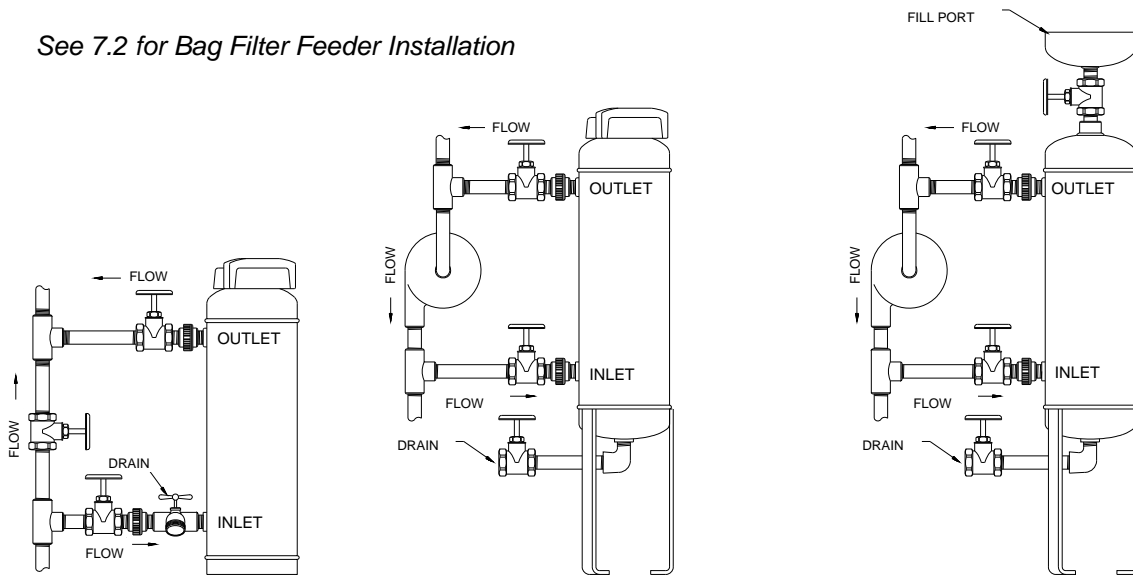

7.2 INSTALLATION DIAGRAM — FILTER (BAG) FEEDERS
Bag Filter Feeders use the upper side port for inlet and the lower side port for outlet.

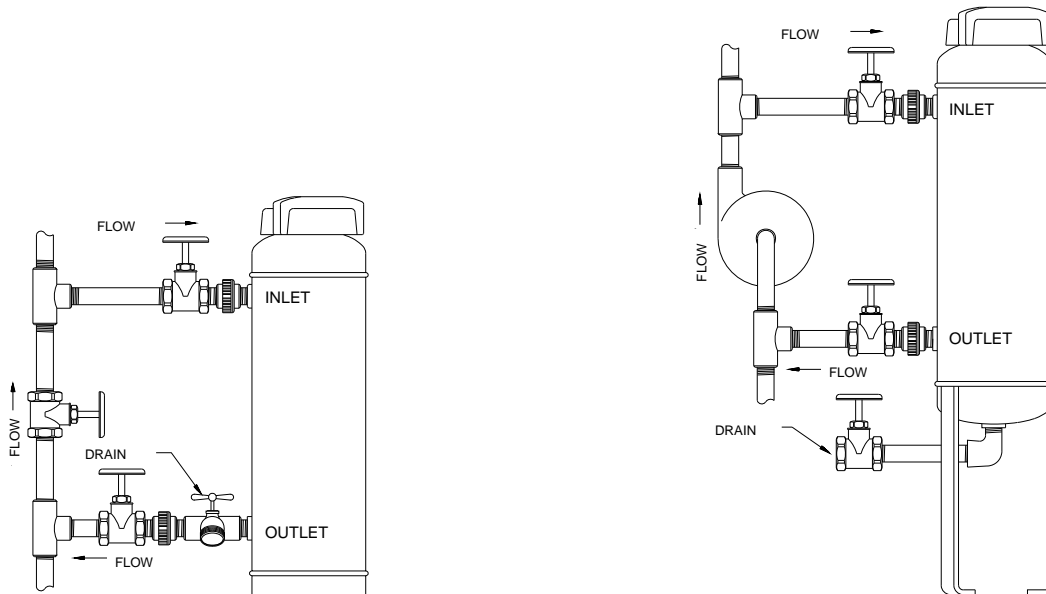

8.0 APPLICATION INFORMATION & TROUBLESHOOTING

Closely follow given guidelines. High temperature and excess pressure are often contributing factors in shortening feeder life. The largest contributing factor to decreasing the life of any feeder is trapped air. Once air is trapped in the feeder, the carbon steel will deteriorate rapidly. Removing excess trapped air is a necessity for any closed loop system.

TROUBLESHOOTING CHART

| SYMPTOM | CAUSE | ACTION |
|----------------------------|--|--|
| Leaking at closure | Improper seating of o-ring | Remove cap, clean surface and reseal cap and closure. If problem persists, replace o-ring. |
| Leaking at fittings | Improper seal or cross threading of fittings | Remove fitting and sealant, then inspect threads for damage. If no damage is observed apply sealant (thread tape or pipe dope) and reseal fitting. If problem persists, replace fitting. |
| Filter damage | High particle content or excess flow rate | Check flow rate and control valves. Inspect filter chamber for solids content. Adjust valves and replace filter. Large particle content is often a typical problem during start up. |
| Interior corrosion | Trapped air or chemical content | Evidence of corrosion near the inside of vessel fill port is an indication of excessive trapped air. To remove trapped air, close isolation valves and fill feeder to the brim and reinstall closure. This should be done by trained personnel. If corrosion is covering body interior, check with chemical supplier for compatibility. Do not use feeder if there is excessive corrosion. |
| Leaking at seams | Unidentified pinhole during manufacture or excessive use | Occasionally, trapped gas during manufacturing may cause pin leaks to occur upon installation. Vessels that begin to leak after some time of service may be exhibiting normal wear. Typically there is no way to repair a vessel that exhibits wear; replacement may be necessary. Consult the factory for recommendation. |

9.0 PVC VALVE PACKAGES

PVC Valve Packages are designed for use with Wingert Bromine Feeders. The chart below lists the available PVC Valve Package and the components of each valve package. For a schematic of each assembly see page 8.

PVC VALVE PACKAGES

| MODEL | DESCRIPTION | INCLUDES KEY NUMBERS * |
|-------------|--|------------------------|
| 3200 | Flat Bottom Bromine Feeder Valve Package | (1) #1, (1) #2 |
| 3201 | Dome Bottom Bromine Feeder Valve Package | (2) #2, (1) #3 |
| 3202 | PE Funnel with 1" Nipple and Valve | (1) #4 |

* See Page 8 for PVC Valve Packages key numbers.

9.0 PVC VALVE PACKAGES (CONTINUED)

PARTS, MATERIALS AND SPECIFICATIONS

| KEY | DESCRIPTION | SPECIFICATIONS |
|-------------------------|---------------------------------|--|
| 1 | Inlet and Drain Valve Assembly | 3/4" PVC Sch. 80 valve, union and nipples, EPDM o-ring, Teflon ball valve seats |
| 2 | Inlet and Outlet Valve Assembly | 3/4" PVC Sch. 80 valve, union and nipples, EPDM o-ring Teflon ball valve seats |
| 3 | Drain Valve Assembly | 3/4" PVC Sch. 80 valve, elbow and nipples, 1" - 3/4" PVC Sch. 80 reducer, EPDM o-ring, Teflon ball valve seats |
| 4 | Option 3202 | PE fill funnel with 1" PVC, Sch. 80 valve and nipples, Teflon ball valve seats |
| MAX. PRESSURE | | 150 PSI (10.4 BAR) |
| MAX. TEMPERATURE | | 120° F (66° C) |

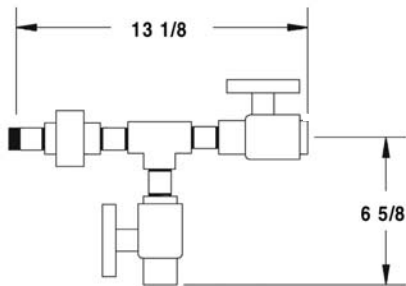

KEY 1

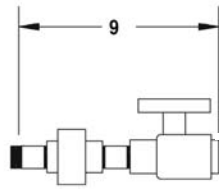

KEY 2

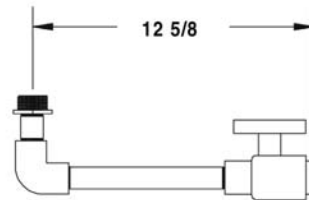

KEY 3

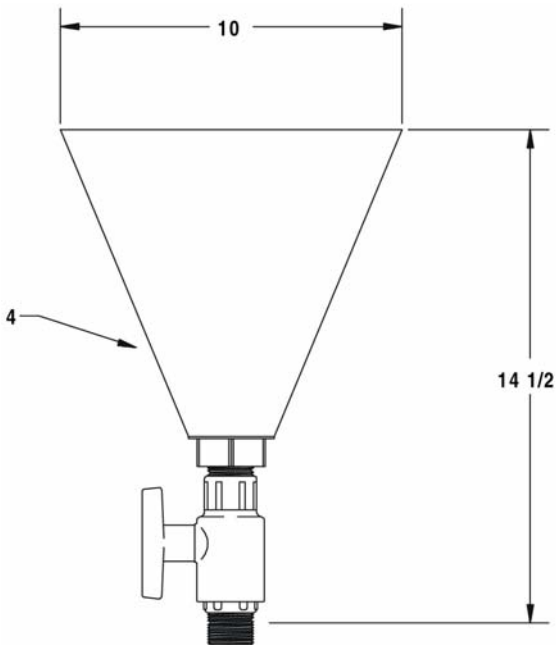

KEY 4

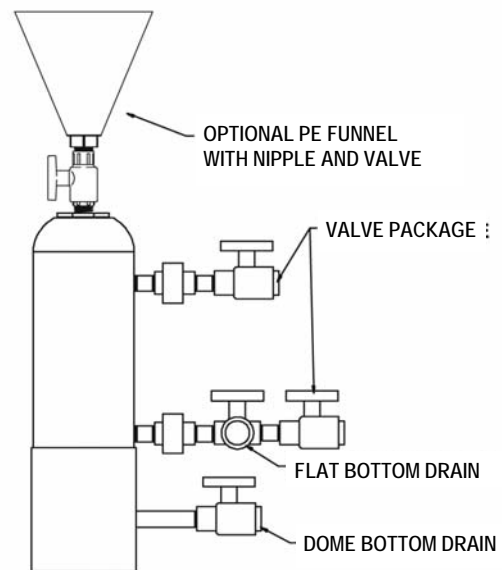

10.0 VALVE PACKAGE INSTRUCTIONS

10.1 UNPACKING

1) Ensure that there has been no damage in shipping. If any damage occurred, please notify the carrier and the J.L. Wingert Co. immediately.

10.2 INSTALLATION

1) Assemble valves and fittings as shown on the diagram below.
 2) Wingert Bypass Feeders and Pleated Filter Feeders should be installed with the inlet at the lower side entry. Wingert Filter Feeders should be installed with the inlet at the upper side fitting.

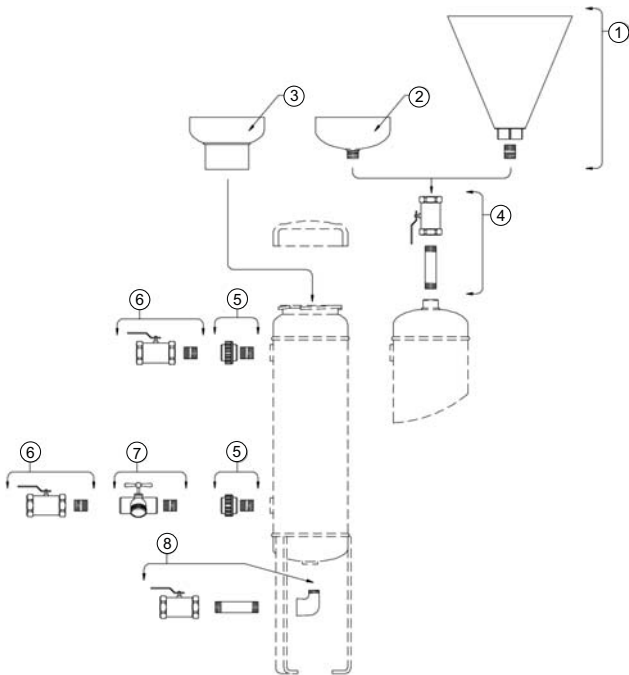

GENERAL NOTES

| KEY | PART NUMBER | DESCRIPTION |
|-----|-------------|--|
| 1 | 3069P | PE FUNNEL: 10" diameter polyethylene fill funnel |
| 2 | 3069 | FUNNEL: 6" diameter carbon steel fill funnel |
| 3 | 3218 | FUNNEL: 6" diameter carbon steel fill funnel with spill guard |
| 4 | 3142 | FILL VALVE: 1" NPT 300PSI brass ball valve and installation nipple |
| 5 | 3079 | UNION: 3/4" NPT union and installation nipple |
| 6 | 3141 | ISOLATION VALVE: 3/4" NPT 300 PSI brass ball valve and installation nipple |
| 7 | 3063 | HOSE BIBB: 3/4" NPT 200 PSI with installation tee and nipple |
| 8 | 3143 | DRAIN VALVE: 3/4" NPT 300 PSI brass ball valve with installation street ell and nipple |

VALVE PACKAGES

| PART NUMBER | DESCRIPTION | INCLUDES KEY NUMBERS |
|-------------|---|------------------------------------|
| 3138 | Flat bottom valve package | (2) #5 (2) #6 (1) #7 |
| 3138F | Flat bottom valve package with HD fill funnel | (1) #3 (2) #5 (2) #6 (1) #7 |
| 3139 | Dome bottom valve package | (2) #5 (2) #6 (1) #8 |
| 3139F | Dome bottom valve package with HD fill funnel | (1) #3 (2) #5 (2) #6 (1) #8 |
| 3140 | High pressure valve package with steel funnel | (1) #2 (1) #4 (2) #5 (2) #6 (1) #8 |
| 3140P | High pressure valve package with PE funnel | (1) #1 (1) #4 (2) #5 (2) #6 (1) #8 |

11.0 FILTER BAG INSTRUCTIONS

You can use your Wingert Bypass Feeder to remove solids from the water in recirculating systems by installing a Wingert Filter Bag Kit. While your feeder is not feeding chemical into the system, place a filter bag into the feeder and allow a continual flow of system water to bypass through the feeder. The filter bag will trap solids such as welding slag, rust chips, loose scale and precipitates in the system water. When the filter bag is full, remove it and replace it with a clean new filter bag.

11.0 FILTER BAG INSTRUCTIONS (CONTINUED)

Filter bag kits may be ordered when ordering a new Wingert Bypass Feeder, or they may be installed in a Wingert Bypass Feeder already in service. J.L. Wingert Co. also manufactures a line of filter feeders. When installing a filter bag kit into a feeder that is already in service, the connection piping will have to be modified slightly to accommodate the tank adapter unit.

Filter bags are fabricated from filament polyester cloth. Filter bags come standard with a 25 micron rating. Other micron ratings are available upon request. Suitable for temperatures up to 200° F, filter bags will withstand a pressure differential of 10 psi. The bag holder is fabricated from carbon steel wire and bar stock. The tank adapter uses brass dual ferrule fittings and 304 stainless steel tubing. The pipe connection is 3/4" FNPT.

Filter bag kits are available in three sizes depending on the size of your feeder:

Filter Bag Kit **3009**: Includes filter bag, bag holder, and tank adapter for 2 gallon feeder

Filter Bag Kit **3010**: Includes filter bag, bag holder, and tank adapter for 5 gallon feeder

Filter Bag Kit **3080**: Includes filter bag, bag holder, and tank adapter for 12 gallon feeder

Filter Bags **3070**: Box of 6 replacement bags, one size fits 2, 5 & 12 gallon feeders

11.1 INSTALLATION

- 1) If the Wingert Bypass Feeder is already installed, be certain that valves **(D)** and **(E)** are closed and drain valve **(F)** is open before starting installation. After flow stops at drain valve **(F)**, remove feeder from system piping.
- 2) Install tank adapter fitting **(B)** in feeder lower 3/4" FNPT fitting. Make certain that tube **(A)** is POINTING STRAIGHT UP before tightening tube nut **(B)**.
- 3) Connect system piping to tank adapter fitting **(C)**. If the feeder is already installed, the lower connection piping will have to be shortened.
- 4) Place filter bag over filter bag holder and tie closure draw string TIGHTLY.
- 5) Lower filter bag holder gently into feeder so that the tapered bag holder opening slips over tube **(A)**. When properly installed, the top of the filter bag will be slightly under the feeder lid and held in place when the lid is installed.
- 6) To replace filter bag, close valves **(D)** and **(E)** and open drain valve **(F)**. Remove feeder lid slowly to make certain that all pressure has been relieved through drain valve **(F)**.
- 7) When drain flow stops at valve **(F)**, remove filter bag and bag holder from the feeder. Replace dirt-filled bag with a fresh new bag, following instructions 4 and 5 above.

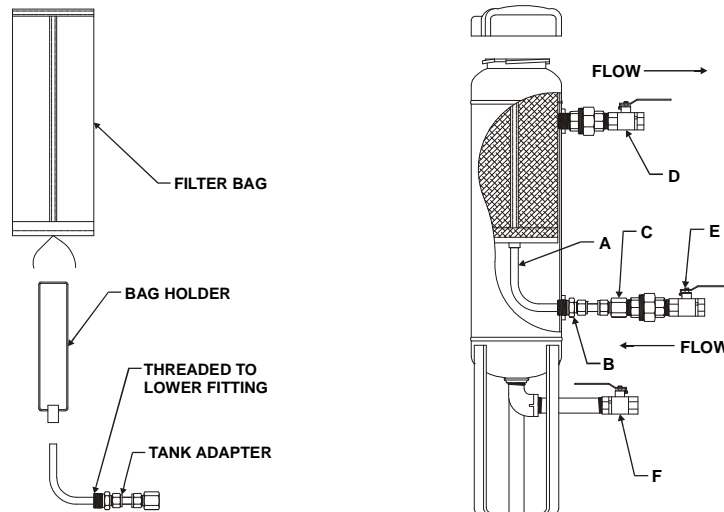

12.0 ACCESSORY ITEMS

Wingert Feeders are offered with a complete line of accessory items. The chart below lists their description and intended use.

BYPASS, FILTER & HIGH PRESSURE BYPASS FEEDERS ACCESSORIES CHART

| PART | DESCRIPTION AND USE | DESIGNED FOR |
|-------------------|--|---|
| 3138 & 3138F | Valve package for flat bottom feeders. Includes inlet & outlet ball valves, unions, installation nipples, hose bib and tee. (Note: 3138F also includes carbon steel HD fill funnel with spill guard.) | Flat bottom feeders with 3 1/2" closure |
| 3139 & 3139F | Valve package for dome bottom feeders. Includes inlet & outlet ball valves, unions, installation nipples and drain valve. (Note: 3139F also includes carbon steel HD fill funnel with spill guard.) | Dome bottom feeders with 3 1/2" closure |
| 3140 & 3140P | Valve package for high pressure feeders. Includes inlet & outlet ball valves, unions, installation nipples, drain valve, 1" fill valve and fill funnel. (Note: 3140P includes PE fill funnel.) | High pressure feeders |
| 3009, 3010 & 3080 | Retrofit filter bag kit assembly for "HD" type feeders. Includes support tube, bag wire, bag and installation fittings. (Note: 3009 = 2 gallon, 3010 = 5 gallon & 3080 = 12 gallon). | "HD" style feeders |
| AR | Air release, 1/4" NPT valve assembly in top dome. | All feeders |
| PG | Pressure gauge, 0-300 PSI assembly in top dome. | All feeders |
| 3061 | 3/4" MNPT in-line PVC Sch. 80 strainer with installation nipple. | All feeders |
| 3086 | 3/4" NPT brass sight flow indicator (125 PSI, 100° F) with installation nipple. | All feeders (PSI/TEMP limited) |
| 3069 & 3069P | 1" NPT fill funnel (3069 is carbon steel & 3069P is polyethylene). | "HP" style feeders |
| 3218 | "HD" series carbon steel fill funnel with spill guard. | "HD" style feeders |

BROMINE FIBERGLASS FEEDERS ACCESSORIES CHART

| PART | DESCRIPTION AND USE | WORKS WITH |
|-------------|---|--------------------------------|
| 3200 | Valve package for flat bottom fiberglass feeders. Includes inlet & outlet ball valves, unions, installation nipples, drain valve and tee. | Flat bottom fiberglass feeders |
| 3201 | Valve package for dome bottom fiberglass feeders. Includes inlet & outlet ball valves, unions, installation nipples and drain valve with elbow and installation nipple. | Dome bottom fiberglass feeders |
| 3202 | PE fill funnel and isolation valve. | All fiberglass feeders |
| 3203 & 3204 | Rechargeable PVC flow through dissolving chamber, 1" NPT fill port, 1/8" port (3203 = 2 gallon, 3204 = 5, 12 & 16 gallon models). | All fiberglass feeders |
| ARPVC | PVC air release valve, installation tee and nipple | All fiberglass feeders |

13.0 MAINTENANCE

When filling or inspecting a feeder, ensure that the vessel is not under pressure. Close isolation valves and open drain valve before opening fill port. **Caution: Opening air release valve will release pressure along with the possibility of residual contents of vessel.**

Feeders generally need very little maintenance. Consult a water treatment specialist to schedule servicing or recharging of the system. It is most important to always purge trapped air when returning feeder to service. Filters should be maintained based on solids in system. Check frequently until schedule can be determined.

14.0 PARTS LISTING

| CATEGORY | PART | DESCRIPTION |
|------------------------------|-------|--|
| CLOSURE | 3071 | 3 1/2" - 1/4 turn cast closure with pressure plate and standard o-ring |
| | 3072 | 200°F standard o-ring |
| | 3073 | 400°F optional o-ring |
| FILTER BAG KITS | 3083 | Bag support wire assembly for 2 & 5 gallon filter bag kits |
| | 3101 | Bag support wire assembly for 12 gallon filter bag kits |
| | 3084 | Filter bag kit support tube assembly for 2 gallon models |
| | 3085 | Filter bag kit support tube assembly for 5 & 12 gallon models |
| | 3070 | Filter bags, box of six filters for above filter bag kits, 25 micron |
| FILTER FEEDERS | 3128 | Perforated basket assembly for 2 & 5 gallon models |
| | 3129 | Perforated basket assembly for 12 gallon models |
| | 3131 | Replacement 25 micron filter bag with ring for 2 & 5 gallon models |
| | 3132 | Replacement 25 micron filter bag with ring for 12 gallon models |
| | 3134 | Box of six filter bags for 2 and 5 gallon filter feeder, 25 micron |
| | 3135 | Box of six filter bags for 12 gallon filter feeder, 25 micron |
| HIGH CAPACITY FILTER FEEDERS | 3160 | Perforated basket assembly for all models |
| | 3161 | Replacement 25 micron filter bag with ring for all models |
| | 3162 | Box of six filter bags for high capacity filter feeders, 25 micron |
| PLEATED FILTER FEEDERS | 3186 | Hanger assembly for all models |
| | 3187 | Pleated 20 micron filter for all models |
| | 3189 | Box of six pleated filters, 20 micron |
| VALVE PACKAGE | 3141 | 3/4" NPT brass ball valve and installation nipple |
| | 3142 | 1" NPT brass ball valve and installation nipple |
| | 3079 | 3/4" NPT union with installation nipple |
| | 3063 | 3/4" NPT 200PSI brass hose bib with installation nipple and tee |
| | 3218 | Funnel, "HD" series steel funnel with spill guard |
| | 3069 | Funnel, 1" NPT steel funnel |
| | 3069P | Funnel, 1" NPT polyethylene funnel |
| FIBERGLASS FEEDERS | 3205 | 2 1/2" CPVC closure with o-ring |
| | 3206 | 4" CPVC closure with o-ring |
| | 3061 | Strainer, 3/4" MNPT in-line PVC Sch. 80 with installation nipple |

Note: Other parts available upon request. Please contact customer service at customerservice@jlwingert.com for information and availability.

P.O. Box 6207 • Garden Grove, CA 92846-6207 / 11800 Monarch St. • Garden Grove, CA 92841-2113 • Phone (714) 379-5519 • Fax (714) 379-5549
Northern California Region • Phone (510) 487-5310 • Southwest Region • Phone (602) 470-1015 • Email: customerservice@jlwingert.com

www.jlwingert.com



VORTEX AIR SEPARATORS | MODELS VA/VAS | INSTALLATION AND OPERATING INSTRUCTIONS

File No: 37.874
Date: SEPTEMBER 22, 2016
Supersedes: 37.874
Date: DECEMBER 18, 2007

Sizes: 4" to 6" - Cast Iron
8" to 12" - Fabricated C. Steel

1.0 VESSEL DESCRIPTION

Armstrong VA/VAS Vortex Air Separators eliminate air quickly and efficiently from heating/cooling systems. Water enters and exits through unique **tangential** connections which promote a low velocity swirling effect in the centre of the unit. Centrifugal force moves the water to the outer edges of the unit and a vortex is formed. Entrained air migrates to the eye of the vortex (lower pressure point) and is evacuated at the top of the separator. The water exits the unit near the bottom of the unit, bubble free, protecting the system against the noise, corrosion and damage associated with entrained air.

VAS models are equipped with a stainless steel strainer.

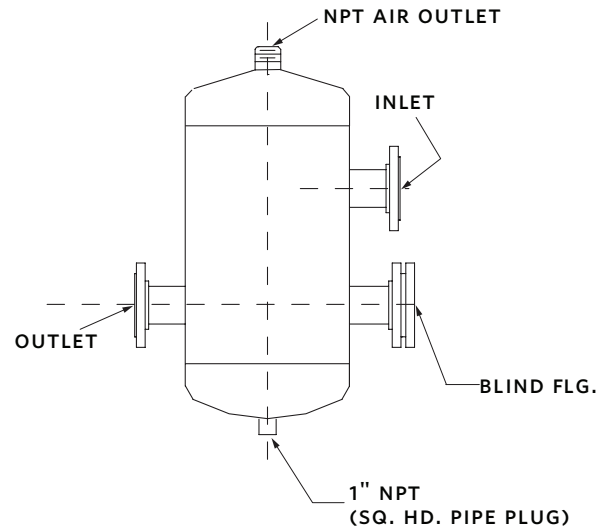

2.0 CONSTRUCTION DETAILS

Materials of construction

Shell: 4" to 6" models: Cast Iron

8" to 12" models: Fabricated steel

Strainer: Stainless steel mesh (¼" x ¾")

Gasket: Non-asbestos

Technical data

Max. working temperature: 375°F (190°C)

Max. working pressure: 4" to 6" models: 160 PSI (1103 kPa)

8" to 12" models: 165 PSI (1140 kPa)

Connection type: 150# Flanged ANSI (RFSO)

3.0 STEPS & PROCEDURE

- Visually inspect the air separator for damage, which may occur during transit.
- A manual drain can be added to help facilitate purging sediment from the air separator.
- VAS models have a strainer that must be removed and cleaned after 24 hours of operation.

| DISTANCE REQUIRED TO REMOVE STRAINER | |
|--------------------------------------|--------------------|
| SIZE | DISTANCE inch (mm) |
| VAS 4 | 16 (406) |
| VAS 5 | 19 (483) |
| VAS 6 | 22 (558) |
| VAS 8 | 26 (660) |
| VAS 10 | 29 (737) |
| VAS 12 | 36 (914) |

TORONTO

23 BERTRAND AVENUE
TORONTO, ONTARIO
CANADA
M1L 2P3
+1 416 755 2291

BUFFALO

93 EAST AVENUE
NORTH TONAWANDA, NEW YORK
U.S.A.
14120-6594
+1 716 693 8813

BIRMINGHAM

HEYWOOD WHARF, MUCKLOW HILL
HALESOWEN, WEST MIDLANDS
UNITED KINGDOM
B62 8DJ
+44 (0) 8444 145 145

MANCHESTER

WOLVERTON STREET
MANCHESTER
UNITED KINGDOM
M11 2ET
+44 (0) 8444 145 145

BANGALORE

#59, FIRST FLOOR, 3RD MAIN
MARGOSA ROAD, MALLESWARAM
BANGALORE, INDIA
560 003
+91 (0) 80 4906 3555

SHANGHAI

NO. 1619 HU HANG ROAD, XI DU TOWNSHIP
FENG XIAN DISTRICT, SHANGHAI
P.R.C.
201401
+86 21 3756 6696

SÃO PAULO

RUA JOSÉ SEMIÃO RODRIGUES AGOSTINHO,
1370 GALPÃO 6
EMBU DAS ARTES
SAO PAULO, BRAZIL
+55 11 4781 5500

ARMSTRONG FLUID TECHNOLOGY
ESTABLISHED 1934

ARMSTRONGFLUIDTECHNOLOGY.COM

**MAKING
ENERGY
MAKE
SENSE™**

Commercial pumps Series 4300, 4360 and 4380

Vertical In-Line pumps

Installation and operating instructions

File No: 43.80
Date: SEPTEMBER 14, 2012
Supersedes: 43.80
Date: SEPTEMBER 15, 2010

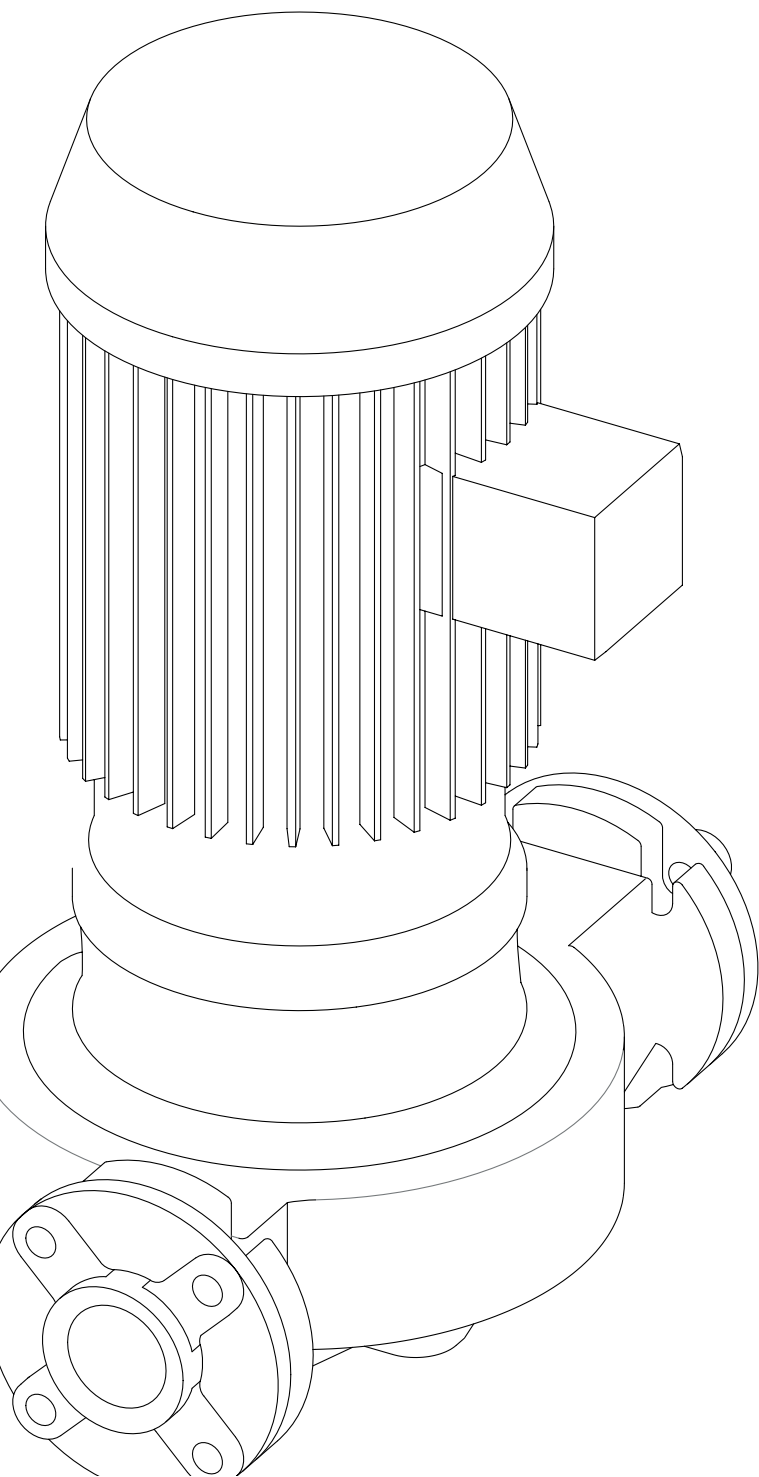

—

—

—

—

CONTENTS

| | | |
|------------|---------------------------|----|
| 1.0 | Introduction | |
| 1.1 | Instructions for safe use | 4 |
| 1.2 | Temperature | 4 |
| 1.3 | Noise levels | 4 |
| 1.4 | Vibration levels | 5 |
| 1.5 | Storage | 5 |
| 1.6 | Uncrating | 5 |
| 1.7 | Handling large VIL units | 5 |
| 2.0 | Installation | 6 |
| 2.1 | Location | 6 |
| 2.2 | Installation | 6 |
| 2.3 | Pump piping - general | 7 |
| 2.4 | Alignment | 8 |
| 2.5 | Starting the pump | 8 |
| 2.6 | General care | 9 |
| 2.7 | Lubrication | 9 |
| 2.8 | System cleanliness | 10 |
| 2.9 | Installation layouts | 10 |

1.0 INTRODUCTION

This document contains specific information regarding the safe installation, operating and maintenance of Vertical In-Line pumps and should be read and understood by installing, operating and maintenance personnel. The equipment supplied has been designed and constructed to be safe and without risk to health and safety when properly installed, operated and maintained. The following instructions must be strictly adhered to. If clarification is needed on any point please contact Armstrong quoting the equipment serial number.

WARNING SYMBOLS



Safety instruction where an electrical hazard is involved.



Safety instruction where non-compliance would affect safety risk.



Safety instruction relating to safe operation of the equipment. (ATTENTION)

1.1 INSTRUCTIONS FOR SAFE USE



No installation of this equipment should take place unless this document has been studied and understood. Handling, transportation and installation of this equipment should only be undertaken by trained personnel with proper use of lifting equipment. See later diagrams for lifting advice. Refer to the pump nameplate for pump speed, pressure and temperature limitations. The limits stated must not be exceeded without written permission from Armstrong.

1.2 TEMPERATURE

Where under normal operating conditions the limit of 68°C/155°F (restricted zone) for normal touch, or 80°C/176°F (unrestricted zone) for unintentional touch, may be experienced, steps should be taken to minimize contact or warn operators/users that normal operating conditions will be exceeded. In certain cases where the temperature of the pumped liquid exceeds the above stated temperature levels, pump casing temperatures may exceed 100°C/212°F and not withstanding pump insulation techniques appropriate measures must be taken to minimize risk for operating personnel.

1.3 NOISE LEVELS

Typical Pumping Unit Sound Pressure Level, Decibels, A-Weighted, at 1 m (3 ft.) from unit.

FIG. 1 Noise levels.

| FRAME DESIGNATION | 1200 RPM | | | | 1800 RPM | | | | 3600 RPM | | | |
|----------------------|-----------|------|-----------|------|-----------|------|-----------|------|-----------|------|-----------|------|
| | ODP | | TEFC | | ODP | | TEFC | | ODP | | TEFC | |
| | hp | dB-A | hp | dB-A | hp | dB-A | hp | dB-A | hp | dB-A | hp | dB-A |
| 140 | 0.75 - 1 | 59 | 0.75 - 1 | 58 | 1 - 3 | 64 | 1 - 2 | 64 | 1.5 - 3 | 70 | 1.5 - 2 | 79 |
| 180 | 1.5 - 2 | 61 | 1.5 - 2 | 61 | 3 - 5 | 66 | 3 - 5 | 68 | 5 - 7.5 | 74 | 3 - 5 | 82 |
| 210 | 3 - 5 | 66 | 3 - 5 | 65 | 7.5 - 10 | 70 | 7.5 - 10 | 73 | 10 - 15 | 76 | 7.5 - 10 | 85 |
| 250 | 7.5 - 10 | 70 | 7.5 - 10 | 69 | 15 - 20 | 74 | 15 - 20 | 78 | 20 - 25 | 78 | 15 - 20 | 88 |
| 280 | 15 - 20 | 75 | 15 - 20 | 74 | 25 - 30 | 74 | 25 - 30 | 82 | 30 - 40 | 80 | 25 - 30 | 89 |
| 320 | 25 - 30 | 77 | 25 - 30 | 77 | 40 - 50 | 78 | 40 - 50 | 83 | 50 - 60 | 83 | 40 - 50 | 94 |
| 360 | 40 - 50 | 80 | 40 - 50 | 80 | 60 - 75 | 80 | 60 - 75 | 89 | 75 - 100 | 88 | 60 - 75 | 95 |
| 400 | 60 - 75 | 82 | 60 - 75 | 84 | 100 - 125 | 83 | 100 | 92 | 125 - 150 | 92 | 100 | 96 |
| 440 | 100 - 125 | 85 | 100 - 125 | 88 | 150 - 200 | 87 | 125 - 150 | 96 | 200 - 250 | 95 | 125 - 150 | 98 |

1.4 VIBRATION LEVELS

Armstrong Vertical In-Line pumps are designed to meet vibration levels set by Hydraulic Institute Standard HI Pump vibration 9.6.4. standard levels are as detailed below:

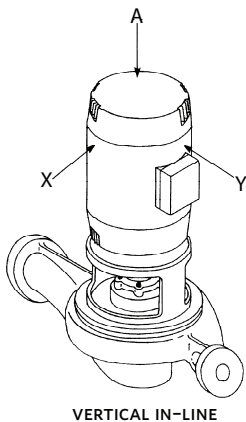
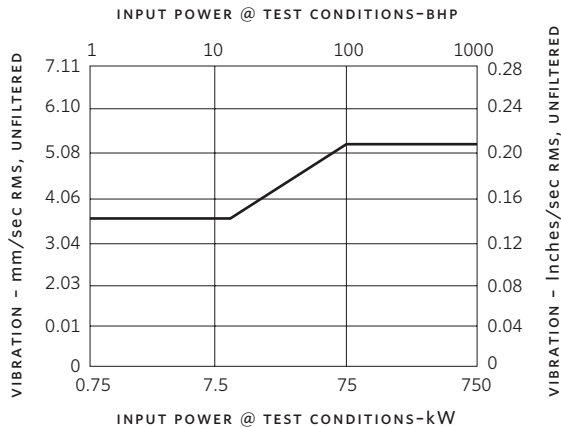

1.5 STORAGE

Pumps not immediately placed into service, or removed from service and stored, must be properly prepared to prevent excessive rusting. Pump port protection plates must not be removed until the pump is ready to connect to the piping.

Rotate the shaft periodically (at least monthly) to keep rotating element free and bearings fully functional.

For long term storage (longer than 3 months), the pump must be placed in a vertical position in a dry environment.

Internal rusting can be prevented by removing the plugs at the top and bottom of the casing and drain or air blow out all water

to prevent rust buildup or the possibility of freezing. Be sure to reinstall the plugs when the unit is made operational. Rust-proofing or packing the casing with moisture absorbing material and covering the flanges is acceptable. When returning to service be sure to remove the drying agent from the pump.

1.6 UNCRATING

Armstrong Vertical In-Line pumps are thoroughly inspected before shipment to assure they meet with your order requirements. After removing the pump from the crate, make sure the equipment is in good order and that all components are received as called for on the packing list. Any shortages or damage should be reported immediately. Use extreme care in handling the unit, placing slings and hooks carefully so that stress will not be imposed on the pump. **Never place cable slings around the pump shaft.** The eye bolts or lifting lugs on the motor are intended for lifting the motor only and not the complete unit.

1.7 HANDLING LARGE VIL UNITS

One effective way of lifting a large Series 4300 unit from the shipment pallet following uncovering the unit is to place lifting hooks through the motor lifting rings or straps around the upper part of the motor and carefully lift sufficiently to stand the pump vertically. Lift only enough to remove the pallet then lower onto a flat surface. The pump and motor unit will free-stand on the casing ribs. Remove the coupling guard and place (2) lifting straps through the pump/motor pedestal (one on each side of the motor shaft) and secure to the lifting device. With the straps in place, using a spacer bar if necessary to protect the motor fan cover, the whole assembly can now be lifted securely and placed in position in the piping.

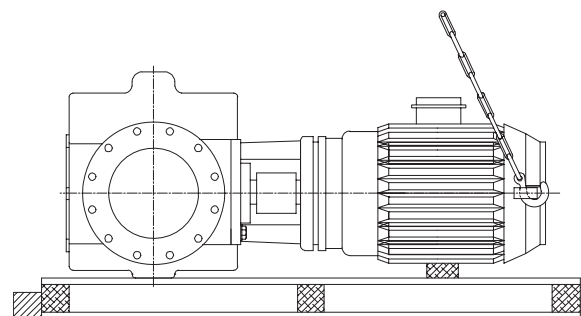

Secure pallet and lift pump vertical using motor eye-bolts lift only to clear pallet then sit on the flat surface.

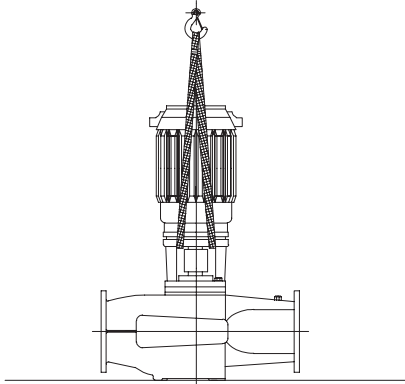

Remove coupling guard and place lifting straps on each side of coupling, use spacer bar if necessary to protect motor fan cover.

IMPORTANT:



Do not run the pump for any length of time under very low flow conditions or with the discharge valve closed. This could cause the water in the casing to reach super heated steam conditions, cause premature failure and cause serious and dramatic damage to the pump and surrounding area.

2.0 INSTALLATION

2.1 LOCATION

In open systems, locate the unit as close as practical to the liquid being pumped, with a short, direct suction pipe. Ensure adequate space is left above and around the unit for operation, maintenance, service and inspection of parts.

In closed systems, where possible, the pumps should be installed immediately downstream of the expansion tank/make-up connection. This is the point of zero pressure change and is necessary for effective pump operation. Do not install more than one expansion tank connection into any closed hydronic system.

Electric motor driven pumps should not be located in damp or dusty locations without special protection.

Airflow into the motor and/or motor fan should not be obstructed.

2.2 INSTALLATION

When installing Vertical In-Line pumps, an important consideration to accrue full added-value from the pump design is to ensure that the pump is pipe-mounted and free to 'float' with any movement, expansion and contraction of the piping. Should any Vertical In-Line pump use supports to the structure it is imperative that no pipe strain is imposed on the pump flanges. Telltale pieces of equipment such as springs or 'waffle' style neoprene isolation pads that distort with pressure to indicate added piping weight, should be used under pump supports should the pump not be truly pipe mounted.

Various installation arrangements are detailed on Pages 6 and 7:

2.2.1

Vertical In-Line pumps may be installed directly in the system piping with no additional support. Pipe hangers are simply sized for the additional weight of the pumping unit. Many pumps are installed in this manner and are mounted at sufficient height to take zero floor space. (Fig. 2.1)

2.2.2

Piping, in many mechanical rooms, is hung close to the ceiling and larger pumps are mounted near ground level for ease of maintenance. Fig 2.2 illustrates such an arrangement with the piping supported at the ceiling and the VIL unit installed with an Armstrong Suction Guide and triple function Flo-Trex valve. Many very large VIL pumps are installed in this manner.

2.2.3

Should additional space saving be required the discharge spool piece and Flo-Trex valve may be replaced by a long-radius elbow and the Flo-Trex valve field converted to a straight-through valve and installed in the vertical discharge pipe. (Fig. 2.3)

2.2.4

Fig 2.4 illustrates a similar arrangement to Fig 2.2 with additional floor mounted pipe-stools isolated from the structure by 'waffle' style neoprene isolation pads under the Armstrong Suction Guide and Flo-Trex valve.

2.2.5

Floor mounted saddle supports (Fig. 2.5) are typical for condenser water pumps where the cooling tower base is near mechanical room elevation.

2.2.6

Where required, additional floor support may be used as shown in Fig. 2.6. Note that the pump should not be rigidly attached to the column. Leave a small gap between pump and column or install a 'waffle' isolation pad under the pump. It is critical that piping be installed in such a manner that the pump does not become a pipe support.

2.2.7

Fig. 2.7 illustrates stanchion plates at the pump inlet and outlet ports that may be supplied for installation convenience. Isolation pads must be used under the legs and monitored as pipe hangers are adjusted to ensure the pump flanges are not supporting the piping. Bolting to the floor or housekeeping pad is not recommended. If the stanchions are bolted down the bolts must be isolated from the stanchion or an inertia base and flexible pipe connectors should be used.

2.2.8

Fig. 2.8 illustrates installations with stanchion plates for seismically active regions. Seismically rated isolation pads or snubbers with bolts isolated from the stanchion plates are installed to restrain the pump during a seismic event. Pipe hangers carry the weight of the equipment as seismic components are designed only to restrain the equipment during a seismic event.

2.2.9

Close coupled in-line units (Series 4360 & 4380) up to 15 hp / 11 kW may be installed with the shaft horizontal. (Fig. 2.9) For horizontal mounting of large units or Series 4300 Split-Coupled style consult the factory. (Fig. 2.9)

2.2.10

Many Vertical In-Line pumps are piped successfully into grooved piping systems. In-line pumps are supported well by grooved piping however flange adapter locking devices or a welded flange at the pump should be used to prevent the possibility of pipe mounted pumps rotating in the piping. Armstrong offers grooved suction guides with cast-in outlet flanges and triple function Flo-Trex valves with inherent locking devices to prevent this possibility. (Fig. 2.10)

2.2.11

Do not support the unit by the motor eye bolts (Fig. 2.11) or by any other part of the motor.

2.2.12

Connecting the pump to a permanent rigid base (Fig. 2.12) is not recommended unless isolated from the piping by flexible

connectors and the base isolated from the building structure on an inertia base. (Fig. 2.12 is generally acceptable when using plastic piping).

IMPORTANT:

All Series 4300 pumps contain a tapped hole in the motor bracket above the discharge flange (see Fig. 2.13) for draining the well. Pipe this drain hole to a floor drain to avoid overflow of the cavity caused by collecting chilled water condensate or from seal failure.

2.3 PUMP PIPING - GENERAL

Never connect a pump to piping, unless extra care is taken to measure and align the piping flanges well. Always start piping from pump.

Use as few bends as possible and preferably long radius elbows.

Do not use flexible connectors on the suction or discharge of a Vertical In-Line pump, unless the pump is rigidly mounted to a foundation.

Ensure piping exerts no strain on pump as this could distort the casing causing breakage or early failure due to pump misalignment.

All connecting pipe flanges must be square to the pipework and parallel to the pump flanges.

Suction and discharge pipes may be increased or decreased at pump nozzle to suit pump capacity and particular conditions of installation. Use eccentric reducers on suction connection with flat side uppermost.

Layout the suction line with a continual rise towards the pump without high points, thus eliminating possibility of air pockets that may prevent the pump from operating effectively.

A strainer of three or four times the area of the suction pipe, installed in the suction line, will prevent the entrance of foreign materials into the pump. $\frac{3}{16}$ " (5 mm) diameter perforations in the strainer is typical.

In open systems, test suction line for air leaks before starting; this becomes essential with long suction line or static lift. Install, at the pump suction, a straight pipe of a length equivalent to 4 or 6 times its diameter; this becomes essential when handling liquids above 120°F (49°C). Armstrong suction guides may be used in place of the straight pipe run and in-line strainer.

Install an isolation valve in both suction and discharge lines on flooded suction application; these valves are used primarily to isolate the pump for inspection or repair.

Install a non-slam non-return check valve in discharge line between pump and isolation valve to protect pump from excessive back pressure and to prevent water running back through the pump in case of driver failure on open systems. An Armstrong Flo-Trex valve may be used in place of non-return check valve and isolation valve on pump discharge.

CAUTION:



Only the discharge valve is to be used to throttle pump flow, not the suction valve. Care must be taken in the suction line layout and installation, as it is usually the major source of concern in centrifugal pump applications.

2.4 ALIGNMENT

Alignment is unnecessary on close-coupled pumps, Series 4360 & 4380, as there is no shaft coupling.

Series 4300 units are accurately aligned at the factory prior to being shipped and do not need re-aligning when installed.

Alignment on a Series 4300 unit may be verified by assuring an equal and parallel gap between coupling halves on both sides of the coupling.

OPERATION

2.5 STARTING THE PUMP



Ensure that the pump turns freely by hand, or with some gentle mechanical help such as a strap or Allen key in coupling bolt.

Ensure that all protective guarding is securely fixed in position.

The pump must be fully primed on start up. Fill the pump casing with liquid and rotate the shaft by hand to remove any air trapped in the impeller. On Series 4300 any air trapped in the casing as the system is filled must be removed by the manual air vent in the seal flush line. **Ensure entrained air is removed from series 4300 pumps, prior to starting, through the air vent on the seal flush line. Open vent until clear of air.**

Series 4360 & 4380 units are fitted with seal flush/vent lines piped to the pump suction area. When these units operate residual air is drawn out of the pump towards the suction piping.

'Bump' or energize the motor momentarily and check that the rotation corresponds with the directional arrow on the pump casing.

To reverse rotation of a three phase motor, interchange any two power leads.

Start the pump with the discharge valve closed and the suction valve open, then gradually open the discharge valve when the motor is at operating speed. The discharge valve may be open slightly at start up to help eliminate trapped air.

When stopping the pump: Close the discharge valve and de-energize the motor.

Do not run the pump against a closed discharge valve for an extended period of time (a few minutes maximum).

Star-Delta motor starters should be fitted with electronic/mechanical interlocks that have a timed period of no more than 40 milliseconds before switching from star (starting) to delta (run) connection yet allow the motor to reach full star (starting) speed before switching to delta (run).

Should the pump be noisy or vibrate on start-up a common reason is overstated system head. Check this by calculating the pump operating head by deducting the suction pressure gauge value from the discharge gauge reading. Convert the result into the units of the pump head as stated on the pump nameplate and compare the values. Should the actual pump operating head be significantly less than the nameplate head value it is typically permissible to throttle the discharge isolation valve until the actual operating head is equal to the nameplate value. Any noise or vibration usually disappears. The system designer or operator should be made aware of this as some adjustment may be required to the pump impeller diameter or drive settings, if applicable, to make the pump suitable for the system as installed.

CAUTION:



Check rotation arrow prior to operating the unit. The rotation of all Armstrong Vertical In-Line units is clockwise when viewed from the drive end. (Looking from on top of/behind the motor).

2.6 GENERAL CARE

Vertical In-Line pumps are built to operate without periodic maintenance, other than motor lubrication on larger units. A systematic inspection made at regular intervals, will ensure years of trouble-free operation, giving special attention to the following:

- Keep unit clean.
- Provide the motor with correctly sized overload protection.
- Keep moisture, refuse, dust or other loose particles away from the pump and ventilating openings of the motor.
- Avoid operating the unit in overheated surroundings (above 100°F/40°C).

WARNING:



Whenever any service work is to be performed on a pumping unit, disconnect the power source from the driver, **lock it off** and tag with the reason. Any possibility of the unit starting while being serviced must be eliminated.

- If mechanical seal environmental accessories are installed, ensure water is flowing through the sight flow indicator and that filter cartridges are replaced as recommended. (See Armstrong files 43.85 & 43.86 for seal environmental instructions).

2.7 LUBRICATION

Pump

Lubrication is not required. There are no bearings in the pump that need external lubrication service.

Large Series 4300 units are installed with a shaft bushing located beneath the impeller that is lubricated from the pump discharge. This bearing is field removable for service on the 20 x 20 x 19 size without disturbing the motor or other major pump components.

Service instructions for the lower bearing is to be found in File no: 43.805.

Motor

Follow the lubrication procedures recommended by the motor manufacturer. Many small and medium sized motors are permanently lubricated and need no added lubrication. Generally if there are grease fittings evident the motor needs periodic lubrication. None if not.

Check the lubrication instructions supplied with the motor for the particular frame size indicated on the motor nameplate.

Mechanical Seal

Mechanical seals require no special attention. The mechanical seal is fitted with a flush line. The seal is flushed from discharge of the pump casing on Series 4300 pumps and is flushed/vented to the suction on close coupled pumps, Series 4360 & 4380.

The Series 4300 pump is flushed from the pump discharge because the mechanical seal chamber is isolated from the liquid in the pump by a throttle bushing. Because the seal chamber is isolated, seal environmental controls such as filters and separators, when installed in the Series 4300 flush line are very effective, as only the seal chamber needs cleansing, and will prolong seal life in HVAC systems.

Do not run the pump unless properly filled with water as the mechanical seals need a film of liquid between the faces for proper operation.

Mechanical seals may 'weep' slightly at start-up. Allow the pump to continue operating for several hours and the mechanical seal to 'seat' properly prior to calling for service personnel.

The following Armstrong files are available for mechanical seal replacement instructions:

- Series 4360 & 4380: File no. 43.81
- Series 4300: P-Base and TCZ Motor Frame – File no. 43.84
TC Motor Frame – File no. 43.88

2.8 SYSTEM CLEANLINESS

Before starting the pump the system must be thoroughly cleaned, flushed and drained and replenished with clean liquid.

Welding slag and other foreign materials, Stop Leak and cleaning compounds and improper or excessive water treatment are all detrimental to the pump internals and sealing arrangement.

Proper operation cannot be guaranteed if the above conditions are not adhered to.

NOTE:

Particular care must be taken to check the following before the pump is put into operation:

- A Pump primed?
- B Rotation OK?
- C Lubrication OK?
- D Pipe work properly supported?
- E Voltage supply OK?
- F Overload protection OK?
- G Is the system clean?
- H Is the area around the pump clean?

WARRANTY

Does not cover any damages to the equipment resulting from failure to observe the above precautions. Refer to Armstrong General Terms and Warranty sheet. Contact your local Armstrong representative for full information.

2.9 INSTALLATION LAYOUTS

FIG. 2.1 Hanger supported pipe mounted.

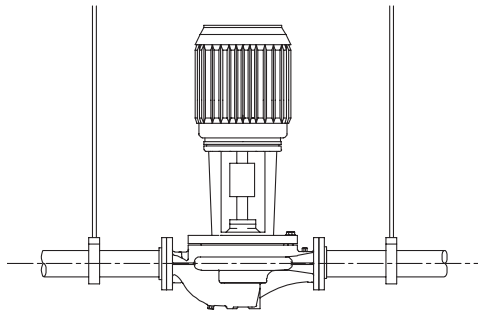

FIG. 2.2 Pipe mounted supported at ceiling.

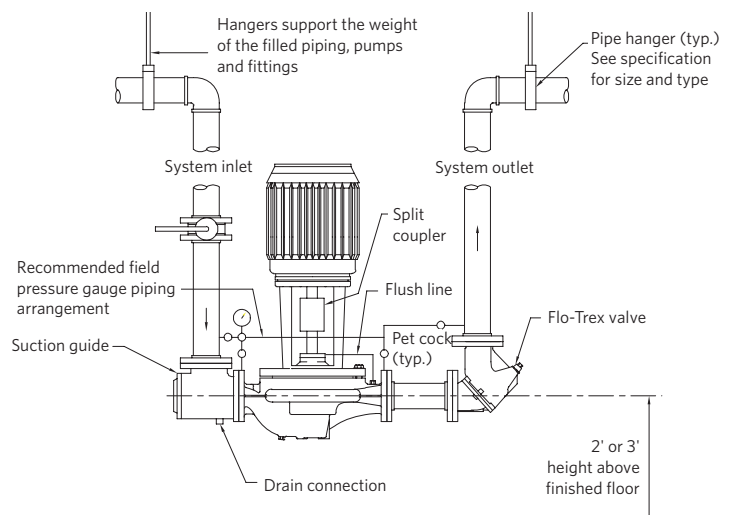

FIG. 2.3 Discharge elbow for minimum footprint.

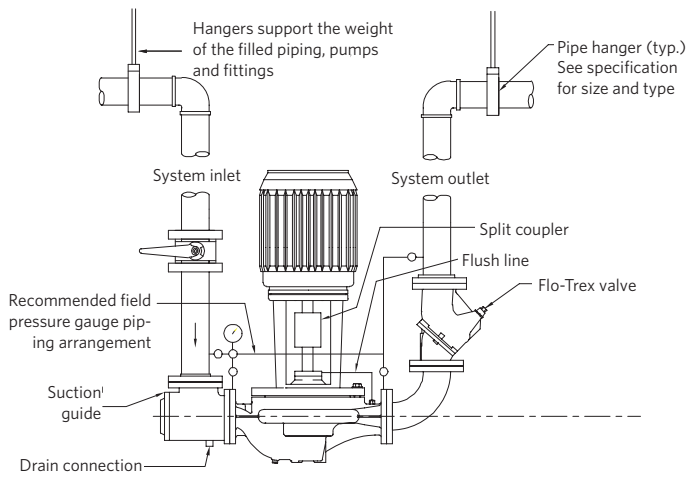

FIG. 2.4 With additional pipe supports.

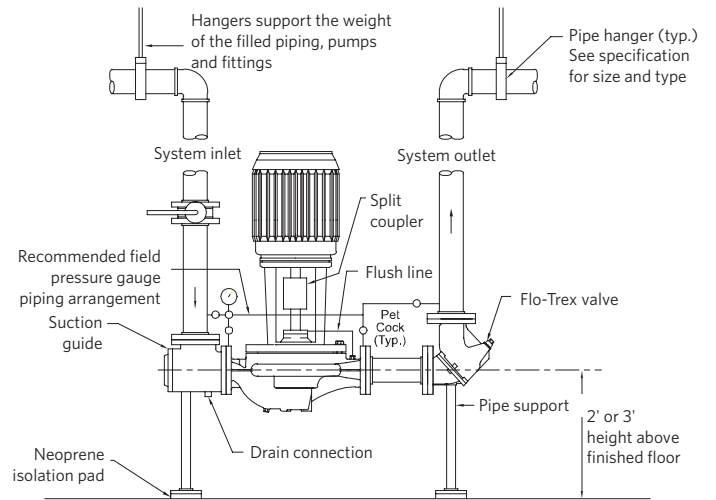

FIG. 2.5 Floor saddle support.

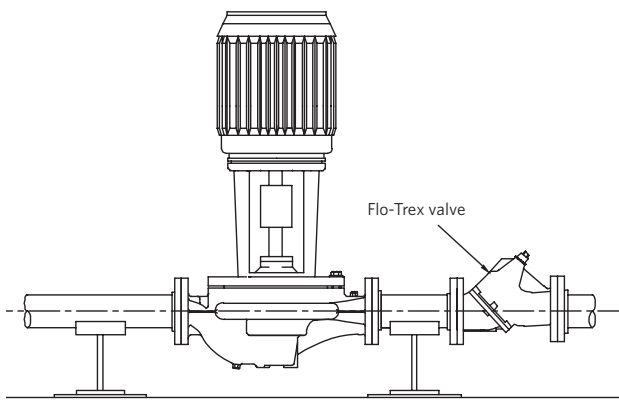

FIG. 2.6 Additional floor support.

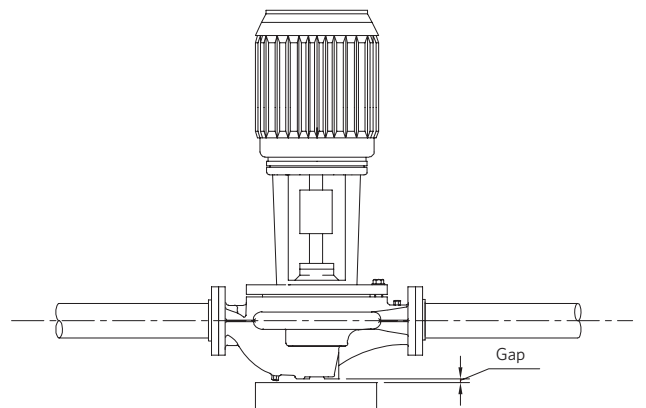

FIG. 2.7 With stanchion plates.

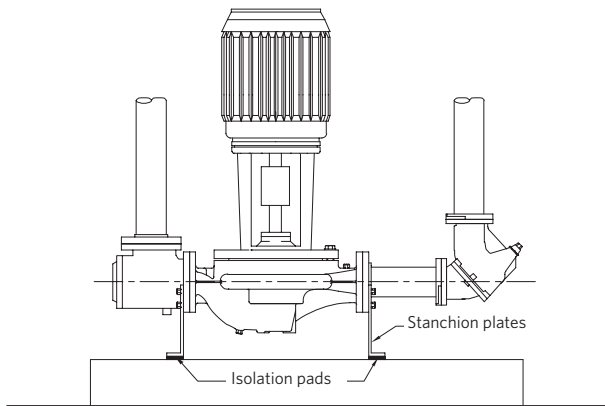

FIG. 2.9 Horizontal mounting - 4360/4380 only to 15 hp (11 kW).

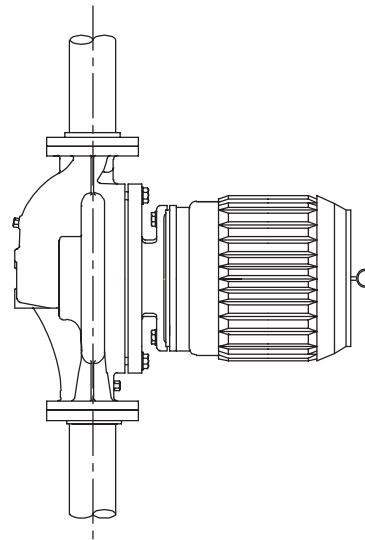

FIG. 2.8 Seismic region installation.

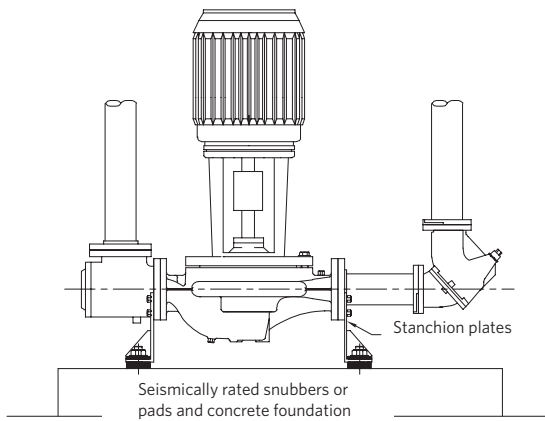

FIG. 2.10 Mounting in grooved pipe systems.

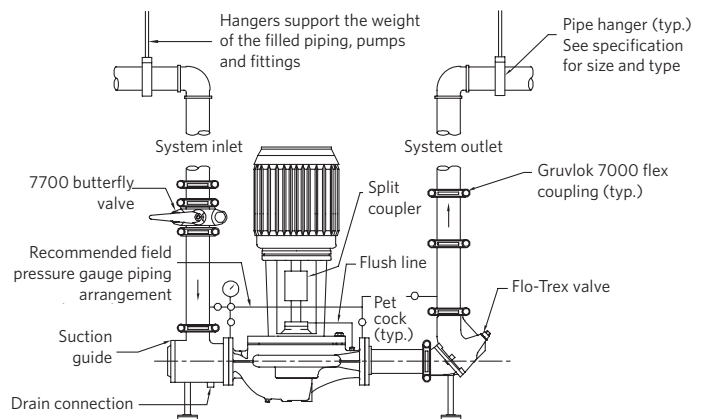

FIG. 2.11 Motor lifting hook supported.

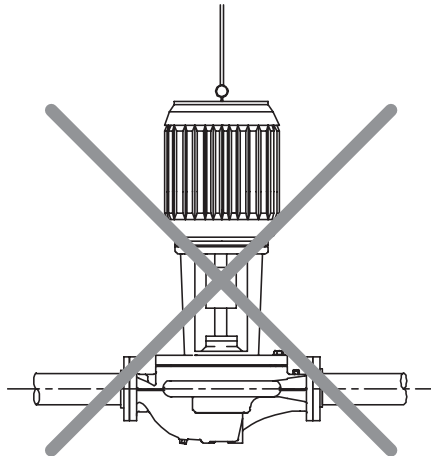

FIG. 2.13 Tapped collection well.

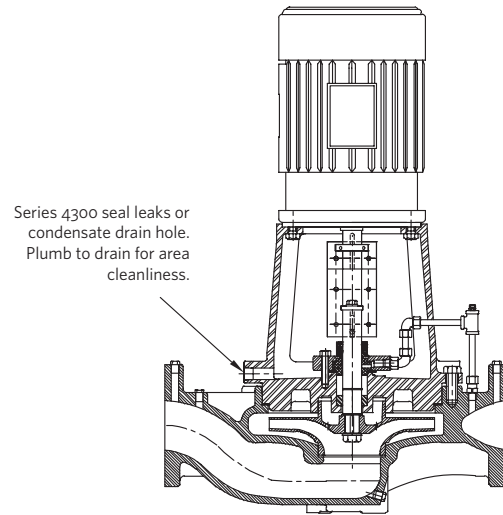
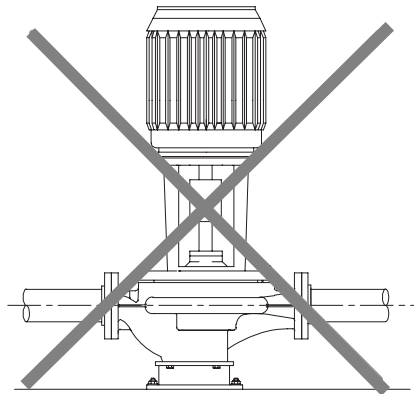

FIG. 2.12 Mounted on rigid base without flexible connectors.



TORONTO

23 BERTRAND AVENUE
TORONTO, ONTARIO
CANADA
M1L 2P3
+1 416 755 2291

BUFFALO

93 EAST AVENUE
NORTH TONAWANDA, NEW YORK
U.S.A.
14120-6594
+1 716 693 8813

BIRMINGHAM

HEYWOOD WHARF, MUCKLOW HILL
HALESOWEN, WEST MIDLANDS
UNITED KINGDOM
B62 8DJ
+44 (0) 8444 145 145

MANCHESTER

WOLVERTON STREET
MANCHESTER
UNITED KINGDOM
M11 2ET
+44 (0) 8444 145 145

BANGALORE

#59, FIRST FLOOR, 3RD MAIN
MARGOSA ROAD, MALLESWARAM
BANGALORE, INDIA
560 003
+91 (0) 80 4906 3555

SHANGHAI

NO. 1619 HU HANG ROAD, XI DU TOWNSHIP
FENG XIAN DISTRICT, SHANGHAI
P.R.C.
201401
+86 21 3756 6696

**MAKING
ENERGY
MAKE
SENSE™**

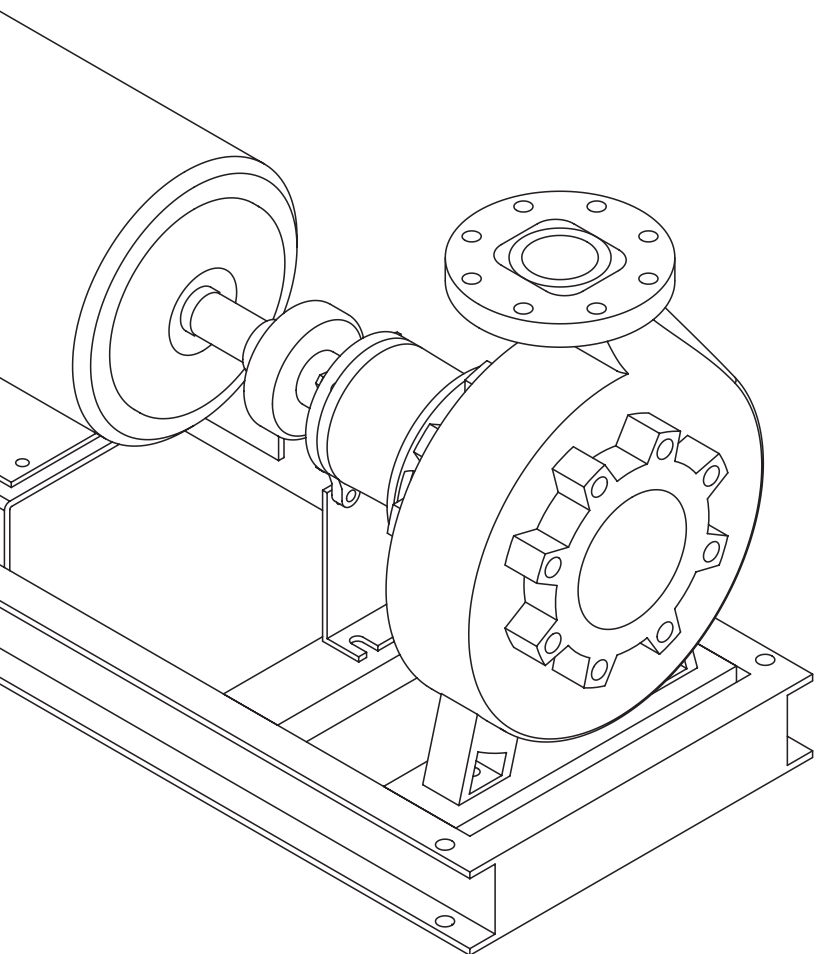

Series 4030

Base mounted pump

Installation and operating instructions

File No: 40.80
Date: DECEMBER 12, 2016
Supersedes: 40.80
Date: JULY 27, 2016

—

—

—

—

CONTENTS

| | |
|---|---|
| General | 4 |
| Inspection | 4 |
| Installation - Series 4030 base mounted Pump | 4 |
| 1.0 Location | 4 |
| 2.0 Storage | 4 |
| 3.0 Foundation and mounting | 4 |
| 4.0 Grouting | 5 |
| 5.0 Pump piping - general | 5 |
| 6.0 Alignment | 6 |
| Operation - Series 4030 base mounted pump | |
| 7.0 Starting pump | 7 |
| 8.0 General care | 7 |
| 9.0 Lubrication | 7 |
| 10.0 System cleanliness | 8 |

GENERAL

Armstrong Centrifugal Pumps, properly installed and given reasonable care and maintenance, will perform satisfactorily for a long period of time. These instructions describe the procedures which should be followed to ensure trouble-free operation. All work should be performed by qualified personnel.

INSPECTION

Armstrong series 4030 Base Mounted pumps are thoroughly tested and inspected before shipment to assure they meet with your order requirements. All units must be carefully examined upon arrival for possible damage during transit. Any evidence of mishandling should be reported immediately to the carrier and noted on the freight bill.

IMPORTANT

Do not run the pump for any length of time under very low flow conditions or with the discharge valve closed. To do so could cause the water in the casing to reach super heated steam conditions and will cause premature failure and could cause serious and dramatic damage to the pump and surrounding area.

INSTALLATION - SERIES 4030 BASE MOUNTED PUMP

1.0 LOCATION

Locate the unit as close as practical to the liquid being pumped, with a short, direct suction pipe. Ensure adequate space is left around the unit for operation, maintenance, service and inspection of parts.

Electric motor driven pumps should not be located in damp or dusty location without special protection.

2.0 STORAGE

Pumps not immediately placed into service, or removed from service and stored, must be properly prepared to prevent rusting and bearing damage.

Bearings protected by oil or grease must be rotated every two to three months to return the lubricant to the upper half of the bearing and prevent ball damage. Do not leave shaft in same position each time.

Internal rusting can be prevented by removing the plugs at the top and bottom of the casing and drain or air blow out all water to prevent rust buildup or the possibility of freezing.

Be sure to reinstall the plugs when the unit is made operational. Rustproofing or packing the casing with moisture absorbing material and covering the flanges is acceptable. When returning to service be sure to remove the drying agent from the pump.

3.0 FOUNDATION AND MOUNTING

- The following text and illustrations are offered as general suggestions for the preparation of a satisfactory foundation.
- Foundation should be sufficiently substantial to absorb any vibration and permanently support the baseplate at all points. This is essential in maintaining the alignment of a direct coupled unit.
- The most satisfactory foundations are made of reinforced concrete and should be at least 2.5 times the shipping weight of the pumping unit. The foundation should be poured well in advance of the installation to allow proper time for drying and curing.
- Foundation bolts of suitable size should be embedded in the concrete located by a drawing or template. Pipe sleeves, 2.5 times the size of the anchor bolts, should be embedded in the concrete, to permit adjustment of the bolts after the concrete has been poured.
- If the unit is to be mounted on fabricated steel work or similar structure, the unit should be set over, or as near as possible to, the supporting beams or walls and to be so supported that the baseplate cannot be distorted nor the alignment disturbed by any yielding or springing of the structure or base.
- When lifting any base mounted pumping unit ensure the unit is **Not** lifted by straps placed under the coupling, pump or motor. The (4) corner holes should be used as a minimum. All (6) holes can be used on larger bases. Secure evenly spaced straps placed under the baseplate is also acceptable for lifting the entire unit.
- When the unit has been placed on the foundation, disconnect the coupling. Do not re-connect the coupling until after the unit has been piped, finally aligned and checked for correct direction of rotation.

- Place pumping unit on the foundation and insert metal wedges on either side of the foundation bolts under base plate. Leave approximately $\frac{3}{4}$ " (19mm) space if grouting.
- Carefully level the unit by adjusting the wedges until shafts of pump and driver are leveled.
- With the proper gauge, check coupling faces and suction and discharge flanges of the pump for vertical position.
- Slight misalignment at this point may be corrected by adjusting the wedges.
- When the baseplate is completely level, the foundation bolts should be tightened evenly and firmly.
- After unit has been in operation for about a week, check the leveling. Any misalignment may be corrected by placing shims between base and driver or pump feet.

4.0 GROUTING

Armstrong's fabricated steel base plate is manufactured to ANSI/HI 1.3.5 rigidity standards for free-standing base plates. As such, no grouting in place is necessary for the base plate to hold shaft alignment. The following instructions are for installers who wish to also secure the base in place with grout:

- Construct a dam around the foundation with grout forms, as shown in the illustration.
- Use a good mixture of non-shrinking grout. The grout should be the consistency of heavy cream.
- Spaces are provided in the base plate to permit pouring of the cement and stirring. Fill under the base completely, stirring to assure proper distribution of the grout. Check to see that the grout flows under the base plate evenly.
- When the grout has hardened thoroughly, usually after 48 hours, final tighten the anchor bolts and remove the grout forms.

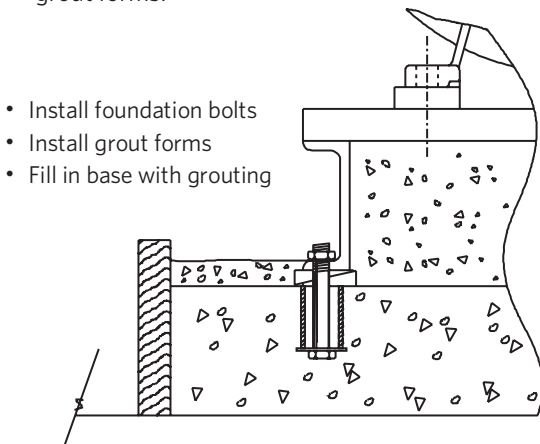

5.0 PUMP PIPING - GENERAL

Never connect a pump to piping, always start piping from pump.

Use as few bends as possible and preferably long radius elbows.

Install good supports under suction and discharge piping with anchors near but independent of the pump.

Make sure piping exerts no strain on pump as this would distort the casing and cause pump misalignment.

Suction and discharge pipes may be increased at pump nozzle to suit pump capacity and particular conditions of installation. Use eccentric reducers on suction connection.

Lay out the suction line with a continual rise towards the pump without high points, thus eliminating possibility of air pockets that may prevent the pump from operating.

A strainer of three or four times the area of the suction pipe, installed in the suction line, will prevent the entrance of foreign materials into the pump. $\frac{3}{8}$ " diameter perforations in the strainer are typical.

Test suction line for air leaks before starting; this becomes essential with long suction line or static lift.

Install, at pump suction, a straight pipe of a length equivalent to 4 or 6 times its diameter; this becomes essential when handling liquids above 120°F (49°C). Armstrong suction guides may be used in place of the straight pipe run and in line strainer.

Install isolation valve(s) in both suction and discharge lines on flooded suction application; this is used mainly to isolate the pump for inspection or repair

Install a non-slam check valve in the discharge line between pump and isolation valve to protect pump from excessive back pressure and to prevent water running back through the pump in case of driver failure. Armstrong Flo-Trex valve may be used in place of check valve and isolation valve on pump discharge.

CAUTION



Discharge valve only must be used to reduce the pump flow, not the suction valve.

Care must be taken in the suction line layout and installation, as it is usually the major source of concern in centrifugal pump applications.

6.0 ALIGNMENT

The pumping unit is accurately aligned at the factory prior to being shipped. All baseplates are flexible to some extent and should not be relied upon to maintain factory alignment.

NOTE: Shipping, handling, uneven foundations, and pipe loads may disrupt the factory alignment.

Alignment should be checked as follows:

- A** After the unit has been set level on the foundation.
- B** After the pipes have been connected.

Accurate alignment is absolutely essential. Proper mechanical operation of the equipment cannot be guaranteed unless the factory alignment is reproduced in the field. All alignment should be made by moving or shimming the motor.

The below instructions should be following to put back the coupling during the alignment process:

- Mount the hubs on the shaft of driving and driven side (see **FIG 1**).
- Insert the spider or DZ elements into the cam section of the hub on the driving or driven side.
- Shift the power packs in axial direction until the distance dimension ϵ is achieved (see **FIG 2**).
- Shift the hubs axially on the shaft to adjust the dimension ϵ to values shown in **TABLE 1**.
- Fasten the hubs by tightening the setscrews DIN EN ISO 4029 with a cup point (tightening torques see **TABLE 1**).

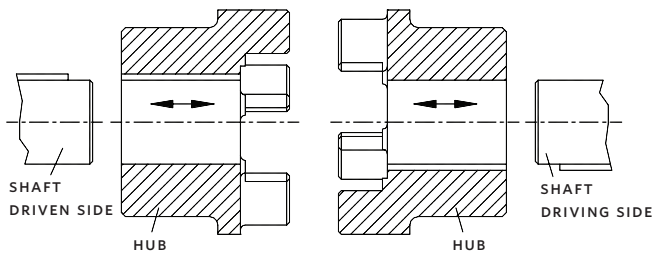

FIG 1: ASSEMBLY OF THE HUBS

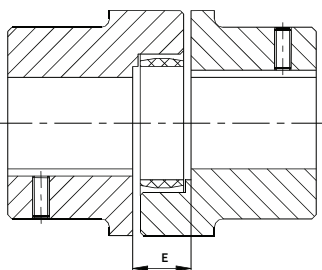

FIG 2: ASSEMBLY OF COUPLING

TABLE 1: Coupling installation

| Size | Tightening torque TA Nm (ft.lbs) | Dimension ϵ mm (inch) |
|------|-------------------------------------|-----------------------------------|
| 14 | 1.5 (1.1) | 13 (0.51) |
| 19 | 2 (1.5) | 16 (0.63) |
| 24 | 2 (1.5) | 18 (0.71) |
| 28 | 10 (7.4) | 20 (0.79) |
| 38 | 10 (7.4) | 24 (0.94) |
| 42 | 10 (7.4) | 26 (1.02) |
| 48 | 10 (7.4) | 28 (1.10) |
| 55 | 17 (12.5) | 30 (1.18) |
| 65 | 17 (12.5) | 35 (1.38) |
| 75 | 17 (12.5) | 40 (1.57) |
| 90 | 40 (29.5) | 42 (1.65) |
| 100 | 40 (29.5) | 50 (1.97) |
| 110 | 80 (59.0) | 55 (2.17) |
| 125 | 80 (59.0) | 60 (2.36) |
| 140 | 140 (103.3) | 65 (2.56) |
| 160 | 140 (103.3) | 75 (2.95) |
| 180 | 140 (103.3) | 85 (3.35) |

The flexible coupling compensates for temperature changes and permits end movement of shafts without them interfering with each other; it will not compensate for misalignment. Faulty alignment will result in noisy pump operation, reduced bearing life, excessive coupling wear and wasted power.

To verify alignment, place a straight edge across the coupling as shown in the following illustration; this must rest evenly on both rims at top, bottom and both sides.

With a pair of inside calipers or thickness gauge, check distance between coupling halves at points where straight edge was used; distance must be equal at all points.

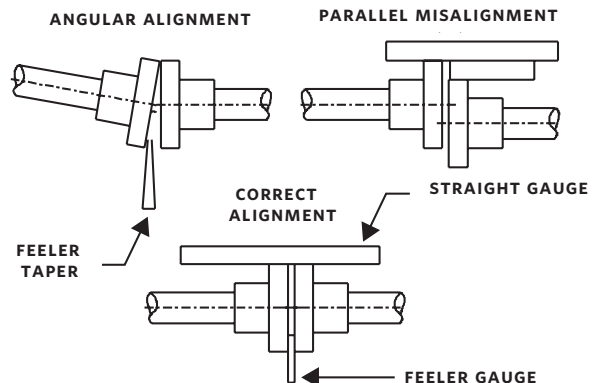

TESTING ALIGNMENT

CAUTION



Be sure to reinstall any temporarily removed coupling guards, prior to starting the pumping unit.

OPERATION - SERIES 4030 BASE MOUNTED PUMP

7.0 STARTING PUMP

The pump must be fully primed on start up. Fill the pump casing with liquid and rotate the shaft by hand to remove any air trapped in the impeller. Air trapped in the casing is automatically vented through the top centre line discharge.

When the piping is connected correctly and the final alignment completed, re-connect the coupling and reinstall the coupling guard.

'Bump' or energize the motor for a fraction of a second and check that the rotation corresponds with the directional arrow on the pump casing.

To reverse rotation of a three phase motor, interchange any two power leads.

Start the pump with the discharge valve closed and the suction valve open, then gradually open the discharge valve when the motor is at operating speed. The discharge valve may be 'cracked' or open slightly at start up to help eliminate trapped air.

When stopping the pump: Close the discharge valve and de-energize the motor.

CAUTION



Centrifugal pump rotation is generally 'clockwise' when viewing from the drive end.

Check rotation arrow prior to operating the unit.

8.0 GENERAL CARE

Base Mounted pumps are built to operate without periodic maintenance with the exception of lubrication of motor bearings, if required. A systematic inspection made at regular intervals, giving special attention to the following, will ensure years of trouble-free operation.

Keep unit clean.

Provide the motor with correctly sized overload protection.

Keep moisture, refuse, dust or other loose particles away from the pump and ventilating openings of the motor.

Avoid operating the unit in overheated surroundings. Generally (Above 100°F(40°C)).

If mechanical seal environmental accessories are installed, ensure water is flowing through the sight flow indicator and that filter cartridges are replaced as recommended.

WARNING



Whenever any service work is to be performed on pumping unit, disconnect power source to driver.

Any possibility of the unit starting while being worked on, must be eliminated.

9.0 LUBRICATION

Pump

Series 4030 pumps are supplied, as standard, with maintenance free, sealed for life, grease lubricated bearings. Site regreasing is not required.

If re-greasable bearing were ordered: Grease lubricated bearings require very little attention. More trouble can be caused by overcharging than undercharging with grease.

Approximately every four months, inject a small quantity of grease (while the pump is running) EXXON MP type H or equal lithium based petroleum grease as follows:

- A** Remove relief hole plug.
- B** Inject grease at grease fitting.
- C** Fill until new grease is visible at relief hole.

If Oil lubricated bearings were ordered: Use non-detergent iso viscosity grade 150 oil, similar to Teresso/Teresstic 150 or Morlina/Tellus 150. Before start-up, check to make sure the oil level is within 0.125"(3mm) of the top of the oil sight glass. Under normal operating conditions, the oil should be changed every six months as follows:

- A** Drain the old oil from the bearing bracket through the drain hole at the bottom of the housing.
- B** Thoroughly flush the bearing bracket with kerosene.
- C** Refill the clean oil through the vent on the top of the bracket until the oil level reaches within 0.125" (3mm) of the top of the oil sight glass.

CAUTION



- Oil lube pumps are not shipped with oil (unless Certified test specified) and must be filled prior to Operation
- Do not oil bearing assembly while the pump is Running.

Motor

Follow the lubrication procedures recommended by the motor manufacturer. Many small and medium sized motors are permanently lubricated, particularly at the coupling end bearing.

Check the lubrication instructions supplied with the motor for the particular frame size indicated on the motor nameplate.

Mechanical seal

Mechanical seals require no special attention. Seal environmental controls, installed in the flush lines, such as filters and separators, will prolong seal life in HVAC systems.

Do not run the pump unless properly filled with water as the mechanical seals need a film of liquid between the faces for proper operation.

10.0 SYSTEM CLEANLINESS

Before starting the pump the system must be thoroughly cleaned, flushed and drained and replenished with clean liquid.

Welding slag and other foreign materials, 'Stop Leak' and cleaning compounds and improper or excessive water treatment are all detrimental to the pump internals and sealing arrangement.

Proper operation cannot be guaranteed if any of these conditions are allowed to exist.

NOTE

Particular care must be taken to check the following before the pump is put into operation:

- A** Coupling guard installed?
- B** Pump primed?
- C** Alignment correct?
- D** Rotation ok?
- E** Lubrication ok?
- F** Pipe work properly supported?
- G** Voltage supply ok?
- H** Overload protection ok?
- I** Is the system clean?
- J** Is the area around the pump clean?

WARRANTY

Refer to Armstrong General Terms and Warranty sheet. Contact your local Armstrong representative for full information.

TORONTO
+1 416 755 2291

BUFFALO
+1 716 693 8813

BIRMINGHAM
+44 (0) 8444 145 145

MANCHESTER
+44 (0) 8444 145 145

BANGALORE
+91 (0) 80 4906 3555

SHANGHAI
+86 21 3756 6696

SÃO PAULO
+55 11 4781 5500