



Western Water Constructors, Inc.
Submittal Cover

Job no. 16-05



CONTRACT NAME: Manteca WQCF Digester Improvements
SPEC SECTION: 15740 Heat Pumps
SUBMITTAL TITLE: Heat Pumps - O&M
FILE NAME: 246-R1_15740-03_Heat Pumps-OM

SUB #: 246
REV #: 1
CODE: 15740-03
DATE: 3/29/2018

WWC REVIEW/COMMENTS: [X] NO EXCEPTIONS [] EXCEPTIONS / DEVIATIONS AS NOTED

REVIEWED BY: ST

SIGNED: [Signature]

WWC HAS REVIEWED THIS SUBMITTAL FOR CONFORMANCE WITH THE PROJECT PLANS & SPECIFICATIONS.

OWNER REVIEW:

Table with 5 rows and 6 columns: ITEM, DESCRIPTION, REVIEW STATUS (A, B, C, D, E). Row 1: Heat Pumps O&M, A: [], B: [], C: [], D: [], E: []

LEGEND: A = No Exceptions Taken B = Make Correction Noted C = Correct & Resubmit
D = Rejected E = Accepted for Record

OWNER COMMENTS:

REVIEWER'S NAME: _____

REVIEWER'S SIGNATURE: _____ DATE: _____



James Long Construction Services, Inc
8560 Younger Creek Drive
Sacramento, Ca 95828
916-379-9524

March 29, 2018

Western Water Constructors
Attn.: Kalie Kreischer

Re: 246-RO-15740-02

Specification Section(s): 15740 Heat Pump O&M

Comments:

All responses will be in bold:

1. Update Missing information once equipment is fabricated.

Missing fields have been updated. Please see the attached O&M.

2. Provide as-built startup information in final O&M.

As-Built Start-up form will be provided in the final O&M.

3. Proper Equipment TAG Number is DIG-HVC-07-540. Include proper tag number on final O&M.

Spelling mistake has been properly updated throughout O&M.

MANTECA WWQF-DIGESTER IMPROVEMENTS PROJECT

SECTION 15740 HEAT PUMPS

DIG-HVC-07-540, DIG-HVC-07-541

GENERAL CONTRACTOR

WESTERN WATER CONSTRUCTORS
707 AVIATION BLVD.
SANTA ROSA, CA 95403
707-540-9640 FAX 707-540-9641

HVAC CONTRACTOR

JAMES LONG CONSTRUCTION SERVICES, INC
8560 YOUNGER CREEK DR.
SACRAMENTO, CA 95828
916-379-9524

ENGINEER

HERWIT ENGINEERING
6200 CENTER ST, SUITE 310
CLAYTON, CA 94517
925-672-6599

TABLE OF CONTENTS

DESCRIPTION	TAB

EQUIPMENT SUMMARY FORMS	1
GENERAL INFORMATION/MANUFACTURERS O&M	2
WARRANTY INFORMATION	3
START-UP FORMS	4

TAB 1

EQUIPMENT SUMMARY FORMS

EQUIPMENT SUMMARY FORM

1. EQUIPMENT ITEM 7.5 TON SPLIT SYSTEM (OUTDOOR UNIT)
2. MANUFACTURER CARRIER
3. EQUIPMENT IDENTIFICATION NUMBER(S) TAG: DIG-HVC-07-540 MODEL: 38AUG SERIAL: 2517C96827
(maps equipment number)
4. LOCATION OF EQUIPMENT OUTSIDE DIGESTER CONTROL BUILDING
5. WEIGHT OF INDIVIDUAL COMPONENTS (OVER 100 POUNDS) 483 LBS
6. NAMEPLATE DATA - Horsepower _____
Amperage 18 MCA
Voltage 430/3/60
Service Factor (S.F.) _____
Speed _____
ENC Type _____
Capacity 7.5 TON 3000 CFM
Other _____
7. MANUFACTURER'S LOCAL REPRESENTATIVE
Name SIGLER
Address 8615 23RD AVE, SACRAMENTO, CA 95826
Telephone Number 916-387-3000
8. MAINTENANCE REQUIREMENTS CHECK UNIT PIPING FOR LEAKAGES, ENSURE AREA AROUND THE
UNIT HAS BEEN CLEARED OF DEBRIS, PERIODCAILY CHECK ELECTRICAL CONNENCTION FOR TIGHTNESS
PERIODICALLY CHECK FAN MOTORT FOR TIGHTNESS
9. LUBRICANT LIST NOT APPLICABLE
10. SPARE PARTS (recommendations) NO SPARE PARTS
11. COMMENTS _____

EQUIPMENT SUMMARY FORM

1. EQUIPMENT ITEM 7.5 TON SPLIT SYSTEM (INDOOR UNIT)
2. MANUFACTURER CARRIER
3. EQUIPMENT IDENTIFICATION NUMBER(S) TAG: DIG-HVC-07-541 MODEL: 40RU SERIAL: 1318U16851
(maps equipment number)
4. LOCATION OF EQUIPMENT ELECTRICAL ROOM AT DIGESTER CONTROL BUILDING
5. WEIGHT OF INDIVIDUAL COMPONENTS (OVER 100 POUNDS) 385
6. NAMEPLATE DATA - Horsepower _____
Amperage FAN MOTOR 3.4 A/UNIT MCA 5.0/MOCP 15.0
Voltage 430/3/60
Service Factor (S.F.) _____
Speed _____
ENC Type _____
Capacity 7.5 TON 3000 CFM
Other _____
7. MANUFACTURER'S LOCAL REPRESENTATIVE
Name SIGLER
Address 8615 23RD AVE, SACRAMENTO CA 95826
Telephone Number 916-387-3000
8. MAINTENANCE REQUIREMENTS CHECK UNIT PIPING FOR LEAKS, ENSURE AREA AROUND THE UNIT
HAS BEEN CLEARED OF DEBRIS, PERIODICALLY CHECK ELECTRICAL CONNECTION FOR TIGHTNESS, PERIODICALLY
CHECK FAN MOTOR FOR TIGHTNESS -CHANGE FILTERS AND BELT WHEN NECESSARY
9. LUBRICANT LIST NOT APPLICABLE
10. SPARE PARTS (recommendations) FILTERS-QUANTITY (4) AT 16" X 24" X 2"
BELT: A52
11. COMMENTS _____

TAB 2

GENERAL INFORMATION

CARRIER OUTDOOR UNIT
DIG-HVC-07-540

38AUQ
Heat Pump Condensing Units
60 Hz
with Puron® (R-410A) Refrigerant
Sizes: 07, 08 and 12



Installation, Start-Up and Service Instructions

CONTENTS

SAFETY CONSIDERATIONS	2
INSTALLATION GUIDELINES	3
Rated Indoor Airflow (cfm)	3
INSTALLATION	7 - 17
Step 1 - Plan for Unit Location	7
Step 2 - Complete Pre-Installation Checks	8
Step 3 - Prepare Unit Mounting Support	8
Step 4 - Rig and Mount the Unit	8
Step 5 - Complete Refrigerant Piping Connections ...	8
Step 6 - Install Accessories	12
Step 7 - Complete Electrical Connections	12
Step 8 - Wind Baffles for Low Ambient Control ...	17
PRE-START-UP	18
System Checks	18
Turn On Crankcase Heaters	18
Preliminary Charge	18
START-UP	18 - 27
38AUQ Units	18
OPERATING SEQUENCE	28
Indoor (Supply) Fan	28
Cooling Unit Without Economizer - Single Stage Units	28
Cooling Unit Without Economizer - Two-Stage Units	28
Fan Cycling	28
Cooling Unit With Economizer	28
Defrost Cycle	28
Supplemental Heating/Emergency Heating	29
Cooling and Heating Shutdown	29
ROUTINE SYSTEM MAINTENANCE	30
Quarterly Inspection (and 30 days after initial start)	30
SERVICE	31 - 44
Refrigeration System	31
Compressor Oil	31
Servicing Systems on Roofs with Synthetic Materials	31
Liquid Line Filter Driers	31
Filed Refrigerant Access Ports	31
Outdoor Coil Metering Devices	31
Refrigerant System Pressure Access Ports	32
Compressor Protection	32
Crankcase Heater	32
Commercial Defrost Board	32
Comfort Alert Diagnostic Module	40
Lubrication	42
Outdoor Coil Maintenance and Cleaning Recommendations	42
Service Parts	44
Fastener Torque Values	44
TROUBLESHOOTING	45
APPENDIX A	
Air Conditioner and Heat Pump with Puron® - Quick Reference Guide	46
APPENDIX B	
Wiring Diagram List	46
APPENDIX C	
Low Ambient Option — Factory Installed	47
START-UP CHECKLIST	51- 52

SAFETY CONSIDERATIONS

Improper installation, adjustment, alteration, service, maintenance, or use can cause explosion, fire, electrical shock or other conditions which may cause personal injury or property damage. Consult a qualified installer, service agency, or your distributor or branch for information or assistance. The qualified installer or agency must use factory-authorized kits or accessories when modifying this product. Refer to the individual instructions package

Follow all safety codes. Wear safety glasses and work gloves. Use quenching cloths for brazing operations and have a fire extinguisher available. Read these instructions thoroughly and follow all warnings or cautions attached to the unit. Consult local building codes and appropriate national electrical codes (in USA, ANSI/NFPA70, National Electrical Code (NEC); in Canada, CSA C22.1) for special requirements.

It is important to recognize safety information. This is the safety-alert symbol . When you see this symbol on the unit and in instructions or manuals, be alert to the potential for personal injury.

Understand the signal words DANGER, WARNING, CAUTION, and NOTE. These words are used with the safety-alert symbol. DANGER identifies the most serious hazards which **will** result in severe personal injury or death. WARNING signifies hazards which **could** result in personal injury or death. CAUTION is used to identify unsafe practices, which **may** result in minor personal injury or product and property damage. NOTE is used to highlight suggestions which **will** result in enhanced installation, reliability, or operation.

38AUQ

WARNING

ELECTRICAL SHOCK HAZARD

Failure to follow this warning could cause personal injury or death.

Before performing service or maintenance operations on unit, turn off main power switch to unit and install lock(s) and lockout tag(s). Ensure electrical service to rooftop unit agrees with voltage and amperage listed on the unit rating plate. Unit may have more than one power switch.

WARNING

UNIT OPERATION AND SAFETY HAZARD

Failure to follow this warning could cause personal injury, death and/or equipment damage.

Puron[®] (R-410A) refrigerant systems operate at higher pressures than standard R-22 systems. Do not use R-22 service equipment or components on Puron refrigerant equipment.

WARNING

PERSONAL INJURY AND ENVIRONMENTAL HAZARD

Failure to follow this warning could cause personal injury or death.

Relieve pressure and recover all refrigerant before system repair or final unit disposal.

Wear safety glasses and gloves when handling refrigerants. Keep torches and other ignitions sources away from refrigerants and oils.

CAUTION

CUT HAZARD

Failure to follow this caution may result in personal injury.

Sheet metal parts may have sharp edges or burrs. Use care and wear appropriate protective clothing, safety glasses and gloves when handling parts and servicing 38AUQ units.

INSTALLATION GUIDELINE

Replacement /Retrofit – R22 to Puron®

Split system heat pumps are intended to be installed with matching indoor sections only. The 38AUQ heat pump outdoor units are matched only with same-size 40RUQ indoor sections. Existing R-22 indoor coils cannot be converted to Puron® R-410A heat pump duty. Only the existing refrigerant piping is a candidate for retrofit use.

Acid test – If the existing system is being replaced because of a compressor electrical failure, assume acid is in system. If system is being replaced for any other reason, use an approved acid test kit to determine acid level. If even low levels of acid are detected, install a 100 percent activated alumina suction line filter drier in addition to the replacement liquid-line filter drier. Operate this system in COOLING ONLY. Remove the suction line filter drier as soon as possible, with a maximum of 72 hr of operation.

Recommendation: Install a ball valve in the liquid line at the filter drier location when installing a suction filter in the suction line.

Evaluate existing refrigerant piping – Reuse of existing refrigerant piping involves three issues: quality (strength) of existing tubing, cleanliness and tube size. R-410A operates at pressures that are 50 to 70% higher than the operating pressures in R-22 systems. It is important that the existing piping set be in excellent physical condition to be considered suitable for re-use with R-410A. If the physical condition of the existing piping set is not excellent, then remove the existing piping and replace with new piping. Refer to Step 5 for a discussion on selecting pipe sizes for these 38AUQ heat pumps; refer to Table 2 for recommended pipe sizes.

If the existing piping set is suitable for re-use with R-410A based on its condition, determine the relative locations and elevation differences between outdoor section (38AUQ) and indoor section (40RUQ) and then check the sizes of the existing lines against the recommended pipe sizes in Table 2 and the MAXIMUM vapor riser pipe size use data in Table 3. Do not use pipe sizes that exceed these maximum vapor riser sizes as oil return at part load conditions in vertical rises may be an issue. Replace any riser sections with reduced pipe sizes if existing pipe sizes exceed these maximum tube size limits.

Installation –

1. Remove the existing evaporator coil or fan coil and install the replacement coil.
2. Drain oil from low points and traps in vapor line tubing if they were not replaced.
3. Remove the existing outdoor unit. Install the new outdoor unit according to these installation instructions.
4. Flush the interconnection piping system with dry Nitrogen to eliminate as much trace of mineral oil as possible.
5. Install the factory-supplied liquid-line filter drier at the indoor coil just upstream of the TXV.

CAUTION

UNIT DAMAGE HAZARD

Failure to follow this caution may result in equipment damage or improper operation.

Never install suction-line filter drier in the liquid-line of a Puron® system.

38AUQ

6. If required, install a 100% activated alumina suction line filter drier at the outdoor unit.
7. Evacuate and charge the system according to the instructions in this installation manual.
8. Operate the system for 10 hr. In COOLING MODE ONLY. Monitor the pressure drop across the suction line filter drier. If pressure drop exceeds 3 psig (21kPa), replace suction-line and liquid-line filter driers. Be sure to purge system with dry nitrogen and evacuate when replacing filter driers. Continue to monitor the pressure drop across suction-line filter drier. Repeat filter changes is necessary. Never leave suction-line filter drier in system longer than 72 hr (actual time).

Rated Indoor Airflow (cfm)

The table below lists the rated indoor airflow used for the AHRI efficiency rating for the units covered in this document.

38AUQ with 40RUQ

Model Numbers	Full Load Airflow (cfm)
38AUQA/B07 – 40RUQ*07	2400
38AUQD/E07 – 40RUQ*07	2400
38AUQ*08 – 40RUQ*08	3000
38AUQA/B12 – 40RUQ*12	3000
38AUQD/E12 – 40RUQ*12	3000

NOTES:

1. MINIMUM CLEARANCE (LOCAL CODES OR JURISDICTION MAY PREVAIL):
 - A. BOTTOM TO COMBUSTIBLE SURFACES: 0 INCHES.
 - B. OUTDOOR COIL, FOR PROPER AIR FLOW: 36 INCHES ONE SIDE, 12 INCHES THE OTHER, THE SIDE GETTING THE GREATER CLEARANCE IS OPTIONAL. STANDARD CLEARANCES ON REMAINING TWO SIDES.
 - C. OVERHEAD: 60 INCHES, TO ASSURE PROPER OUTDOOR FAN OPERATION.
 - D. BETWEEN UNITS: CONTROL BOX SIDE, 42 INCHES PER NEC.
 - E. BETWEEN UNIT AND UNGROUNDED SURFACES: CONTROL BOX SIDE, 36 INCHES PER NEC.
 - F. BETWEEN UNIT AND BLOCK OR CONCRETE WALLS AND OTHER GROUNDED SURFACES: CONTROL BOX SIDE, 42 INCHES PER NEC.
2. WITH EXCEPTION OF THE CLEARANCE FOR THE OUTDOOR COIL AS STATED IN NOTE 1B, A REMOVABLE FENCE OR BARRICADE, REQUIRES NO CLEARANCE.
3. UNITS MAY BE INSTALLED ON COMBUSTIBLE FLOORS MADE FROM WOOD OR CLASS A, B OR C ROOF COVERING MATERIAL.

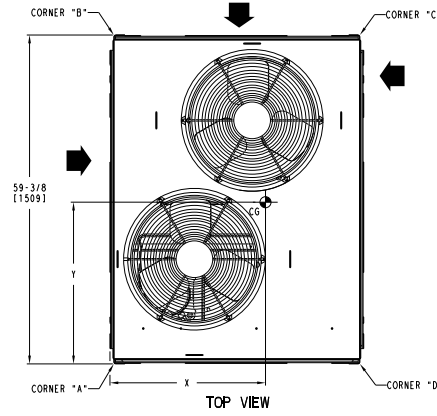

SERVICE VALVE CONNECTIONS		
UNIT	SUCTION	LIQUID
38AUQ07	1-1/8 [28.6]	3/8 [9.5]
38AUQ08	1-1/8 [28.6]	1/2 [12.7]
38AUQ12	1-3/8 [34.9]	1/2 [12.7]

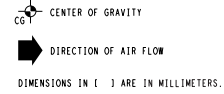

38AUQ

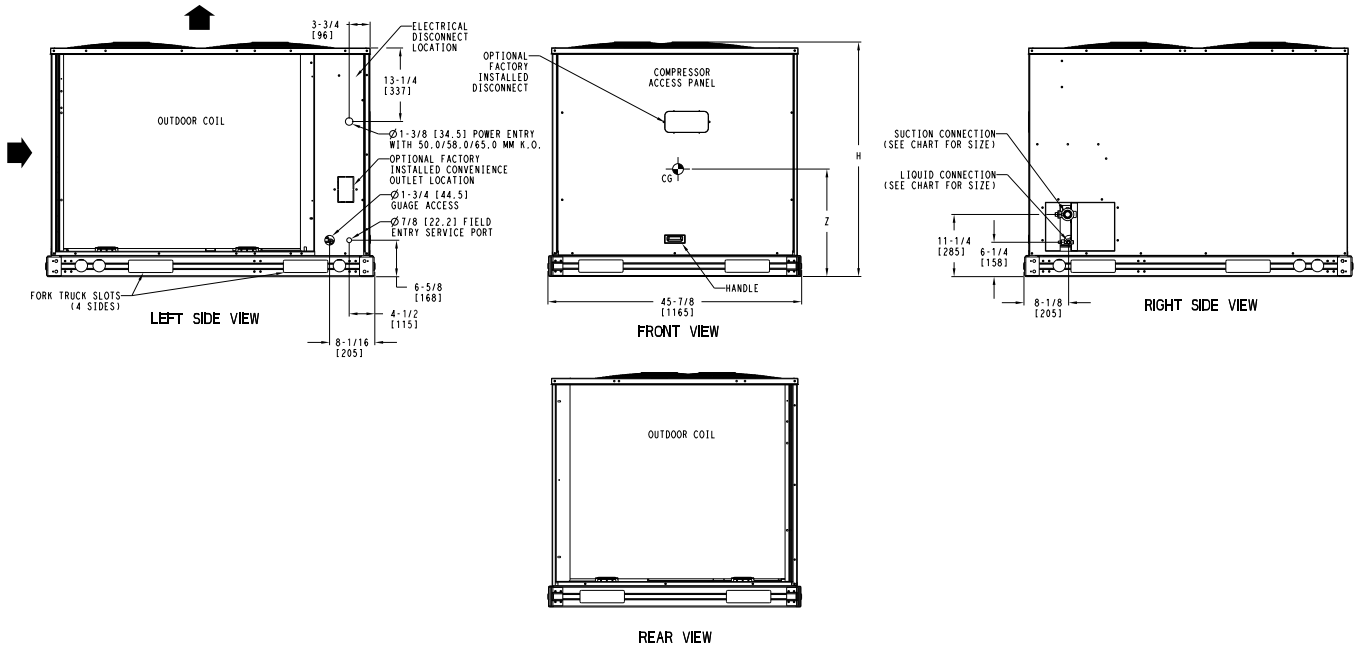

UNIT	Standard Weight		Corner A		Corner B		Corner C		Corner D		Center of Gravity			Unit Height
	lbs.	kg.	lbs.	kg.	lbs.	kg.	lbs.	kg.	lbs.	kg.	X	Y	Z	H
38AUQ*07	444	201	134	61	97	44	90	41	123	56	22 [559]	25 [635]	13 [330]	42-3/8 [1076]
38AUQ*08	483	219	162	74	110	50	85	39	125	57	20 [508]	24 [610]	21 [533]	42-3/8 [1076]
38AUQ*12	575	261	186	84	126	57	106	48	157	71	21 [533]	24 [610]	23 [584]	50-3/8 [1280]

Fig. 1 - 38AUQ*07-12 Unit Dimensions

C150341

Table 1A — Physical Data — 38AUQ*07-12 Units — 60 Hz English

UNIT	38AUQA/B07	38AUQD/E07	38AUQA/B08	38AUQA/B12	38AUQD/E12
NOMINAL CAPACITY (tons)	6	6	7.5	10	10
OPERATING WEIGHTS (lb)					
Aluminum-Fin Coils	444	444	483	575	575
REFRIGERANT TYPE‡	R-410A	R-410A	R-410A	R-410A	R-410A
Operating Charge (w/ fan coil), Typical (lb)†	18.0	18.0	21.0	27.0	27.0
Shipping Charge (lb)	9.0	9.0	9.0	9.0	9.0
COMPRESSOR					
Qty...Type	1...Scroll	1...2 Stage Scroll	1...Scroll	1...Scroll	2...Scroll
OUTDOOR FANS					
Qty...Rpm	2...1100	2...1100	2...1100	2...1100	2...1100
Motor Hp	1/4	1/4	1/4	1/4	1/4
Diameter (in)	22	22	22	22	22
Nominal Airflow (Cfm Total)	6,000	6,000	6,000	6,000	6,000
Watts (Total)	610	610	610	610	610
OUTDOOR COIL (Qty)	1...Round Tube/Plate Fin (RTPF)				
Face Area (sq ft total)	17.5	17.5	23.0	28.1	28.1
Rows/Fins per inch (FPI)	2/17	2/17	2/17	2/17	2/17
CONTROLS					
Pressurestat Settings (psig)					
High Cutout	630 ±10	630 ±10	630 ±10	630 ±10	630 ±10
Cut-in	505 ±20	505 ±20	505 ±20	505 ±20	505 ±20
Low Cutout	27 ±3	27 ±3	27 ±3	27 ±3	27 ±3
Cut-in	44 ±5	44 ±5	44 ±5	44 ±5	44 ±5
PIPING CONNECTIONS (in. ODS)					
Qty...Vapor	1...1 ¹ / ₈	1...1 ¹ / ₈	1...1 ¹ / ₈	1...1 ³ / ₈	1...1 ³ / ₈
Qty...Liquid	1... ³ / ₈	1... ³ / ₈	1...1/2	1...1/2	1...1/2

LEGEND

ODS — Outside Diameter Sweat (socket)

‡ Unit is factory-supplied with partial charge only.

† Typical operating charge with 25 ft of interconnecting piping.

38AUQ

Table 1B — Physical Data — 38AUQ*07-12 Units — 60 Hz SI

38AUQ

UNIT	38AUQA/B07	38AUQD/E07	38AUQA/B08	38AUQA/B12	38AUQD/E12
NOMINAL CAPACITY (kW)	21.1	21.1	26.4	35.1	35.1
OPERATING WEIGHT (kg)					
Aluminum-Fin Coils	201	201	219	261	261
REFRIGERANT TYPE‡	R-410A	R-410A	R-410A	R-410A	R-410A
Operating Charge (w/ fan coil), Typical (kg)†	8.2	8.2	9.5	12.2	12.2
Shipping Charge (kg)	4.1	4.1	4.1	4.1	4.1
COMPRESSOR					
Qty...Type	1...Scroll	1...2 Stage Scroll	1...Scroll	1...Scroll	2...Scroll
OUTDOOR FANS					
Qty...r/s	2...18	2...18	2...18	2...18	2...18
Motor Hp NEMA	1/4	1/4	1/4	1/4	1/4
Diameter (mm)	560	560	560	560	560
Nominal Airflow (L/s)	2832	2832	2832	2832	2832
Watts (Total)	610	610	610	610	610
OUTDOOR COIL (Qty)			1...Round Tube/Plate Fin (RTPF)		
Face Area (sq m total)	1.6	1.6	2.1	2.6	2.6
Rows/Fins per Meter (Fins/m)	2/670	2/670	2/670	2/670	2/670
CONTROLS					
Pressurestat Settings (kPa)					
High Cutout	4344 ±70	4344 ±70	4344 ±70	4344 ±70	4344 ±70
Cut-in	3482 ±138	3482 ±138	3482 ±138	3482 ±138	3482 ±138
Low Cutout	186 ±21	186 ±21	186 ±21	186 ±21	186 ±21
Cut-in	303 ±35	303 ±35	303 ±35	303 ±35	303 ±35
PIPING CONNECTIONS (in. ODS)					
Qty...Vapor	1...1 ¹ / ₈	1...1 ¹ / ₈	1...1 ¹ / ₈	1...1 ³ / ₈	1...1 ³ / ₈
Qty...Liquid	1... ³ / ₈	1... ³ / ₈	1... ¹ / ₂	1... ¹ / ₂	1... ¹ / ₂

LEGEND

NEMA — National Electrical Manufacturers Association

ODS — Outside Diameter Sweat (socket)

‡ Unit is factory-supplied with partial charge only.

† Typical operating charge with 7.62 m of interconnecting piping.

Position	1	2	3	4	5	6	7	8	9	10	11	12	13	14	15	16	17	18
Example	3	8	A	U	Q	A	1	2	A	0	C	6	-	0	A	0	A	0

Model Type

38AU = Carrier Condensing Unit
Puron® R-410A Refrigerant

Type of Coil

Q = Heat Pump Scroll Compressor

Refrigerant Options

A = None
B = Low Ambient
D = Single Circuit / 2-Stage (sizes 07 and 12 only)
E = Single Circuit / 2-Stage with Low Ambient (sizes 07 and 12 only)

Nominal Tonnage

07 = 6 Tons
08 = 7.5 Tons
12 = 10 Tons

Not Used

A = Not Used

Not Used

0 = Not Used

Coil Options (RTPF)

A = Cu/Al
B = Precoat (Cu/Al)
C = E-Coat (Cu/Al)
M = Cu/Al with Louvered Hail Guard
N = Precoat (Cu/Al) with Louvered Hail Guard
P = E-Coat (Cu/Al) with Louvered Hail Guard

Packaging

0 = Standard
1 = LTL

Electrical Options

A = None
C = Non-Fused Disconnect

Service Options

0 = None
1 = Un-powered Convenience Outlet
2 = Powered Convenience Outlet

Not Used

A = Place Holder

Base Unit Controls

0 = Electro-Mechanical Controls

Design Rev

- = Initial Release

Voltage

1 = 575/3/60
5 = 208/230/3/6
6 = 460/3/60

38AUQ

Fig. 2 - Model Number Nomenclature

C150342

POSITION NUMBER	1	2	3	4	5	6	7	8	9	10
TYPICAL	0	5	1	5	C	1	2	3	4	5

POSITION

1-2
3-4
5
6-10

DESIGNATES

Week of manufacture (fiscal calendar)
Year of manufacture ("15" = 2015)
Manufacturing location
Sequence number

Fig. 3 - Serial Number Nomenclature

C150336

INSTALLATION

Jobsite Survey

Complete the following checks before installation.

1. Consult local building codes and the NEC (National Electrical Code) ANSI/NFPA 70 for special installation requirements.
2. Determine unit location (from project plans) or select unit location.
3. Check for possible overhead obstructions which may interfere with unit lifting or rigging.

Step 1 — Plan for Unit Location

Select a location for the unit and its support system (pad, rails or other) that provides for the minimum clearances required for safety. This includes the clearance to combustible surfaces, unit performance and service access below, around and above unit as specified in unit drawings. See Fig. 4.

Select a unit mounting system that provides adequate height to allow for removal and disposal of frost and ice that will form during the heating-defrost mode.

NOTE: Consider also the effect of adjacent units on airflow performance and control box safety clearance.

Do not install the outdoor unit in an area where fresh air supply to the outdoor coil may be restricted or when recirculation from the condenser fan discharge is possible. Do not locate the unit in a well or next to high walls.

Evaluate the path and required line length for interconnecting refrigeration piping, including vapor riser requirements and liquid line lift; a heat pump system will have one of each type in opposite modes. Relocate sections to minimize the length of interconnecting tubing.

DO NOT BURY REFRIGERATION LINES.

Although unit is weatherproof, avoid locations that permit water from higher level runoff and overhangs to fall onto the unit.

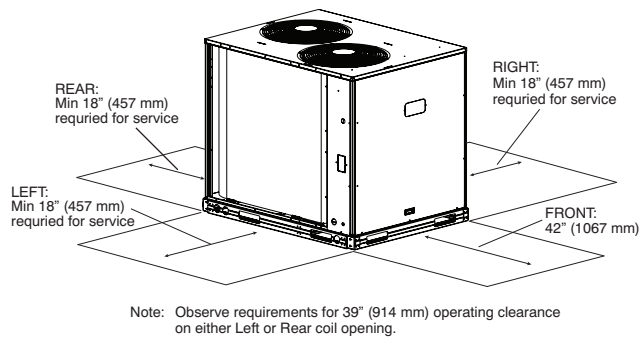

Fig. 4 - Service Clearance Dimensional Drawing

Step 2 — Complete Pre-Installation Checks

Check Unit Electric Characteristic —

Confirm before installation of unit that voltage, amperage and circuit protection requirements listed on unit data plate agree with power supply provided.

Un-crate Unit —

Remove unit packaging except for the top skid assembly, which should be left in place until after the unit is rigged into its final location.

Inspect Shipment —

File a claim with shipping company if the shipment is damaged or incomplete.

Consider System Requirements —

- Consult local building codes and National Electrical Code (NEC, U.S.A.) for special installation requirements.
- Allow sufficient space for airflow clearance, wiring, refrigerant piping, and servicing unit. See Fig. 1 for unit dimensions and weight distribution data.

- Locate the unit so that the outdoor coil (condenser) airflow is unrestricted on all sides and above.
- The unit may be mounted on a level pad directly on the base channels or mounted on raised pads at support points. See Tables 1A and 1B for unit operating weights. See Fig. 1 for weight distribution based on recommended support points.

NOTE: If vibration isolators are required for a particular installation, use the data in Fig. 1 to make the proper selection.

Step 3 — Prepare Unit Mounting Support

Slab Mount —

Provide a level concrete slab that extends a minimum of 6 in. (150 mm) beyond unit cabinet. Install a gravel apron in front of condenser coil air inlet to prevent grass and foliage from obstructing airflow.

Step 4 — Rig and Mount the Unit

Rigging —

These units are designed for overhead rigging. Refer to the rigging label for preferred rigging method. Spreader bars are not required if top crating is left on the unit. All panels must be in place when rigging. As further protection for coil faces, plywood sheets may be placed against the sides of the unit, behind cables. Run cables to a central suspension point so that the angle from the horizontal is not less than 45 degrees. Raise and set the unit down carefully.

If it is necessary to roll the unit into position, mount the unit on longitudinal rails, using a minimum of 3 rollers. Apply force to the rails, not the unit. If the unit is to be skidded into position, place it on a large pad and drag it by the pad. Do not apply any force to the unit.

Raise from above to lift the unit from the rails or pad when unit is in its final position.

After the unit is in position, remove all shipping materials and top crating.

Step 5 — Complete Refrigerant Piping Connections

Refrigerant lines must be carefully designed and constructed to ensure equipment reliability and efficiency. Line length, pressure drop, compressor oil return, and vertical separation are several of the design criteria that must be evaluated. See Table 2.

IMPORTANT: Do not bury refrigerant piping underground.

IMPORTANT: A refrigerant receiver is not provided with the unit. Do not install a receiver.

Table 2 – 38AUQ*07-12 Piping Recommendations (Single-Circuit Unit)

R-410A	Equivalent Length					
	Ft	0-38	38-75	75-113	113-150	
Model	Length Linear	0-25	25-50	50-75	75-100	
	Length Equiv	0-38	38-75	75-113	113-115	
38AUQ*07	Liquid Line	3/8	3/8	3/8 1/2	3/8 1/2	
	Max Lift					
	Cool	25	50	48 75	39 100	
	Heat	25	50	46 60	31 60	
	Vapor Line	7/8	7/8	1-1/8	1-1/8	
	Charge (lbs)	17.8	18.8	20.3 22.6	21.4 24.5	
38AUQ*08	Liquid Line	1/2	1/2	1/2	1/2	
	Max Lift					
	Cool	25	50	75	100	
	Heat	25	50	60	60	
	Vapor Line	7/8 1-1/8	1-1/8	1-1/8	1-1/8	
	Charge (lbs)	20.9	23.0	24.9	26.8	
38AUQ*12	Liquid Line	1/2	1/2	1/2	1/2 3/8	
	Max Lift					
	Cool	25	50	75	85 100	
	Heat	25	50	60	60 60	
	Vapor Line	7/8 1-1/8	1-1/8	1-1/8	1-1/8 1-3/8	
	Charge (lbs)	26.8	28.8	30.7	33.4 37.2	
Legend:						
Length Equiv	Equivalent tubing length, including effects of refrigeration specialties devices					
Liquid Line	Tubing size, inches OD.					
Max Lift	Maximum liquid lift at maximum permitted liquid line pressure drop					
Cooling	• Indoor unit ABOVE outdoor unit					
Heating	• Indoor unit BELOW outdoor unit					
Vapor Line	Tube size, inches OD					
Charge	Charge Quantity, lbs. Calculated for both liquid line sizes (where applicable), but only with large suction line size (where applicable)					
NOTE:	For applications with linear length greater than 100 ft (30.5 m), contact your local Carrier representative.					

38AUQ

Check Vertical Separation —

If there is any vertical separation between the indoor and outdoor units, check to ensure that the separation is within allowable limits. Relocate equipment if necessary.

Provide Safety Relief —

If local codes dictate an additional safety relief device, purchase locally and install locally. Installation will require the recovery of the factory shipping charge before the factory tubing can be cut and the supplemental relief device is installed.

Refrigerant Line Sizing —

Consider the length of the piping required between the outdoor and indoor units. The maximum allowable line length is 100 ft (30.5 m). See Table 2. Refrigerant vapor piping should be insulated.

Risers in Heat Pump Piping Systems —

Elevation differences between the outdoor unit and the indoor unit in heat pump systems will create two riser line conditions – one in the liquid line in one mode and one in the vapor line in the opposite mode. See the following table to identify which lines are risers in this installation.

Mode	38AUQ Unit BELOW ID Unit	38AUQ Unit ABOVE ID Unit
	Riser in	Riser in
Cooling	Liquid	Vapor (Suction Gas)
Heating	Vapor (Discharge Gas)	Liquid

Liquid Line Riser: Refer to Pipe Sizing Table, Table 2; observe Max Lift limits for liquid line according to unit mode, equivalent line length and pipe size.

Vapor Line Riser: Refer to Table 3 for maximum pipe size in single pipe vapor risers. All pipe size recommendations in Pipe Sizing Table, Table 2, satisfy these maximum vapor line sizes. If this installation is re-using existing piping, check the vapor line sizes against these maximum values; replace riser sections with these pipe sizes if necessary.

Table 3 – Maximum Vapor Line Sizes

38AUQ Size	38AUQ Unit BELOW ID Unit	38AUQ Unit ABOVE ID Unit
	Max Diameter, Single Pipe (in.)	
(A,B)07	1-1/8	1-5/8
(D,E)07	1-1/8	1-1/8
(A,B)08	1-3/8	1-3/8
(A,B)12	1-5/8	1-5/8
(D,E)12	1-3/8	1-3/8

Table 4 – Puron-duty Filter Drier(s)

Model-Size	Qty	Liquid Line OD	Desiccant Volume	Part Number Ref
38AUQ*07	1	3/8-in	8 cu. in.	KH43LG088
38AUQ*08	1	1/2-in	16 cu. in.	KH43LG089
38AUQ*12	1	1/2-in	16 cu. in.	KH43LG089

Table 5 – Refrigerant Specialties Part Numbers

LIQUID LINE SIZE (in.)	LIQUID LINE SOLENOID VALVE (LLSV)	SOLENOID COIL	SIGHT GLASS	FILTER DRIER
3/8	EF680033 plus EF680039 biflow kit	EF680037	KM680008	Provided with unit See Table 4
1/2	EF680035 plus EF680039 biflow kit	EF680037	KM680004	
5/8	EF680036 plus EF680039 biflow kit	EF680037	KM680005	

38AUQ

Install Filter Drier and Moisture Indicator —

Every unit **MUST** have a bi-directional filter drier in the liquid line. Locate the filter drier(s) at the indoor unit, close to the indoor coil’s thermal expansion valve (TXV) inlets.

38AUQ units include one Puron-duty filter drier, shipped in cartons attached to the unit basepan. Remove the filter drier and prepare to install in the liquid line at the indoor coil. Do not remove connection fitting plugs until ready to connect and braze the filter drier into the liquid line position. See Table 4.

IMPORTANT: A refrigerant receiver is not provided with the unit. Do not install a receiver.

Installation of liquid line moisture indicating sightglass in each circuit is recommended. Locate the sightglass(es) between the outlet of the filter drier and the TXV inlet.

Refer to Table 5 for recommendations on refrigeration specialties.

Select the filter drier for maximum unit capacity and minimum pressure drop. Complete the refrigerant piping from the indoor unit to the outdoor unit before opening the liquid and vapor service valves at the outdoor unit.

Install Liquid Line Solenoid Valves —

It is recommended that a bi-directional solenoid valve be placed in the main liquid line (see Figs. 5 & 6) between the outdoor unit and the indoor coil. Locate the solenoid valve at the end of the liquid line, near the outdoor unit connections, with flow direction arrow pointed at the outdoor unit. Refer to Table 5. (A liquid line solenoid valve is required when the liquid line length exceeds 75 ft [23 m].) This valve prevents refrigerant migration (which causes oil dilution) to the compressor during the off cycle, at low outdoor ambient temperatures. Wire the solenoid according to the unit label diagram.

⚠ CAUTION

UNIT DAMAGE HAZARD

Failure to follow this caution may result in equipment damage.

Failure to use a solenoid valve relay (SVR) PNO HN61PC005 may cause overload of Comfort Alert Diagnostic Module (CADM) and compressor alarm lock out.

CAPACITY CONTROL LIQUID LINE SOLENOID VALVE - 38AUQ units are single-stage only designs. DO NOT USE a capacity control liquid line solenoid valve on the indoor coil.

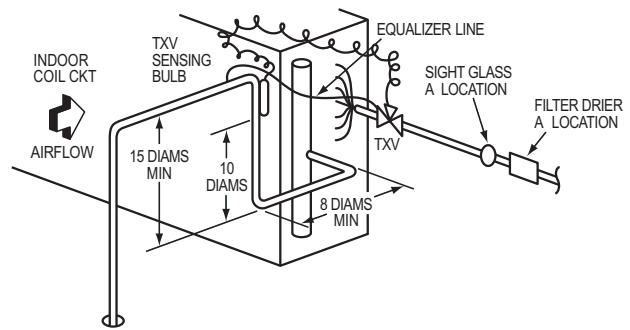

LEGEND

TXV — Thermostatic Expansion Valve

C11036

Fig. 5 - Location of Sight Glass(es) and Filter Driers (typical 38AUQ size 07 & 08)

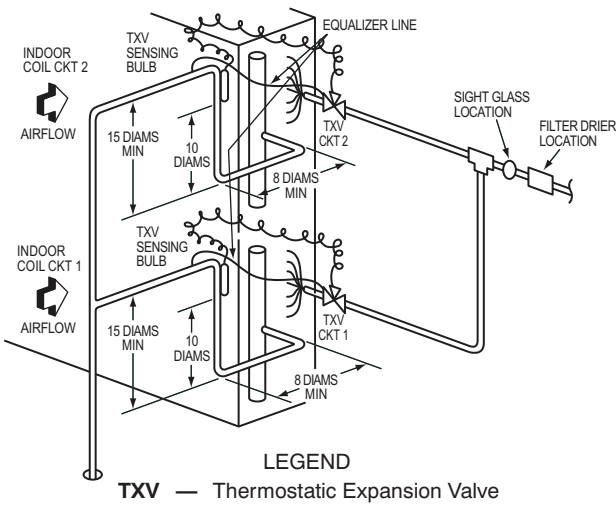

Fig. 6 - Location of Sight Glass(es) and Filter Driers (typical 38AUQ size 12)

Table 6 – Minimum Outdoor Air Operating Temperature

UNIT	% COMPRESSOR CAPACITY	MINIMUM OUTDOOR TEMP — F (C)*	
		Standard Unit	Head Pressure Control†
38AUQ 07		35 (1.7)	-20 (-28.9)
38AUQ 08	100	35 (1.7)	-20 (-28.9)
38AUQ 12		35 (1.7)	-20 (-28.9)

* Applies to Cooling mode of operation only.
 † Wind baffles (field-supplied and field-installed) are recommended for all units with low ambient head pressure control. Refer to Low Ambient Control Installation Instructions (shipped with accessory) for details.

Table 7 – Insulation for Vapor Line Exposed to Outdoor Conditions

LENGTH OF EXPOSED VAPOR LINE*		INSULATION THICKNESS†	
ft	m	in.	mm
10	3	3/8	10
25	8	1/2	13
35	11	3/4	19
50	15	3/4	19

* Recommended vapor line insulation for piping exposed to outdoor conditions to prevent loss of heating during heating cycle. When vapor line goes through interior spaces, insulation should be selected to prevent condensation on cooling cycle. Heating capacity should be reduced 1000 Btuh (295 W) if over 35 ft (11 m) of vapor line with 3/4 in. (19 mm) insulation is exposed to outdoor conditions.
 † Closed cell foam insulation with a thermal conductivity of: 0.28 Btu • in./ft² • h • °F (0.04 W/m • °C).

Make Piping Connections —

Piping connections at the 38AUQ unit are ball valves with stub tube extensions. Do not open the unit service valves until all interconnecting tube brazing as been completed.

The stub tube connections include 1/4-in SAE service fittings with Schrader valve cores (see Fig. 7). Before making any brazed connections to the unit service valves, remove both Schrader valve caps and cores and save for re-installation. Connect a source for nitrogen to one of these service fittings during tube brazing to prevent the formation of copper oxides inside the tubes at brazed joints.

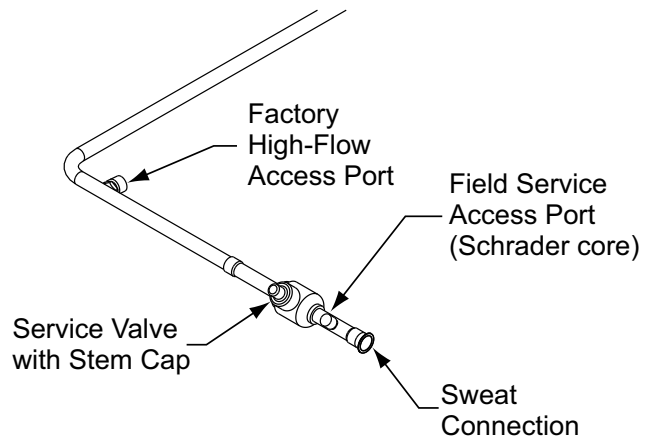

Fig. 7 - Typical Piping Connection Assembly

When connecting the field tubing to the 38AUQ service valves, wrap the valves in wet rags to prevent overheating

Pressure-test all joints from outdoor unit connections over to the indoor coil, using nitrogen as pressure and with soap-and-bubbles.

When pressure-testing is completed, remove the nitrogen source at the outdoor unit service valves and re-install the two Schrader valve cores. Torque the cores to 2-3 in-lbs (23-34 N-cm).

Where vapor line is exposed to outdoor air, line must be insulated. See Table 7 for insulation requirements.

Evacuation/Dehydration —

Evacuate and dehydrate the connected refrigeration system(s) (excluding the 38AUQ unit) to 500 microns using a two-stage vacuum pump attached to the service ports outside the 38AUQ service valves, following description in GTAC II, Module 4, System Dehydration.

⚠ WARNING

UNIT OPERATION AND SAFETY HAZARD

Failure to follow this warning could cause personal injury, death and/or equipment damage.

Puron® (R-410A) refrigerant systems operate at higher pressures than standard R-22 systems. Do not use R-22 service equipment or components on Puron refrigerant equipment.

IMPORTANT: Charge in Cooling mode only!

Preliminary Charge —

Before starting the unit, charge R-410A liquid refrigerant into the high side of each 38AUQ circuit through the liquid service valve(s). The amount of refrigerant added must be at least 80% of the operating charge listed in Table 2 for LINEAR line length LESS the factory charge quantity (if factory shipping charge has not been removed). See the following example.

38AUQ

Allow high and low side pressures to equalize. If pressures do not equalize readily, charge R-410A vapor (using special service manifold with expansion device) into the vapor line service port for the low side of system to assure charge in the evaporator. Refer to GTAC II, Module 5, Charging, Recover, Recycling, and Reclamation for liquid charging procedures.

Example:

38AUQ*08

60-ft (18.3 m) linear line length

Equivalent line length 90-ft (27.4 m)

Liquid Lift: 20-ft (6.1 m)

Select line sizes from Table 2:

Liquid $\frac{1}{2}$ in

Vapor $1\text{-}\frac{1}{8}$ in.

Charge 23.0 lbs (at 75-ft linear length)

80% of Operating Charge:

$0.80 \times 23.0 = 17.6$ lbs

Factory Shipping Charge: 9 lbs

Field-charge quantity: 17.6 lbs – 9.0 lbs = 8.6 lbs

For linear line lengths longer than 100 ft (30.5 m), contact your local Carrier representative for system charge value.

Step 6 — Install Accessories

Accessories requiring modifications to unit wiring should be completed now. These accessories may include Winter Start controls, Low Ambient controls, phase monitor, Compressor LOOut. Refer to the instructions shipped with the accessory.

Step 7 — Complete Electrical Connections

⚠ WARNING

ELECTRICAL SHOCK HAZARD

Failure to follow this warning could result in personal injury or death.

Do not use gas piping as an electrical ground. Unit cabinet must have an uninterrupted, unbroken electrical ground to minimize the possibility of personal injury if an electrical fault should occur. This ground may consist of electrical wire connected to unit ground lug in control compartment, or conduit approved for electrical ground when installed in accordance with NEC (National Electrical Code); ANSI/NFPA 70, latest edition (in Canada, Canadian Electrical Code CSA [Canadian Standards Association] C22.1), and local electrical codes.

NOTE: Field-supplied wiring shall conform with the limitations of minimum 63°F (33°C) rise.

Field Power Supply —

If equipped with optional Powered Convenience Outlet: The power source leads to the convenience outlet's transformer primary are not factory connected. Installer must connect these leads according to required operation of the convenience outlet. If an always-energized convenience outlet operation is desired, connect the source leads to the line side of the unit-mounted disconnect. (Check with local codes to ensure this method is acceptable in your area.) If a de-energize via unit disconnect switch operation of the convenience outlet is desired, connect the source leads to the load side of the unit disconnect. On a unit without a unit-mounted disconnect, connect the source leads to compressor contactor C and indoor fan contactor IFC pressure lugs with unit field power leads.

Field power wires are connected to the unit at line-side pressure lugs on compressor contactor C and TB1 (see wiring diagram label for control box component arrangement) or at factory-installed option non-fused disconnect switch. Max wire size is #4 AWG (copper only).

NOTE: TEST LEADS - Unit may be equipped with short leads (pigtails) on the field line connection points on contactor C or optional disconnect switch. These leads are for factory run-test purposes only; remove and discard before connecting field power wires to unit connection points. Make field power connections directly to line connection pressure lugs only.

⚠ WARNING

FIRE HAZARD

Failure to follow this warning could result in intermittent operation or performance satisfaction.

Do not connect aluminum wire between disconnect switch and condensing unit. Use only copper wire. (See Fig. 8.)

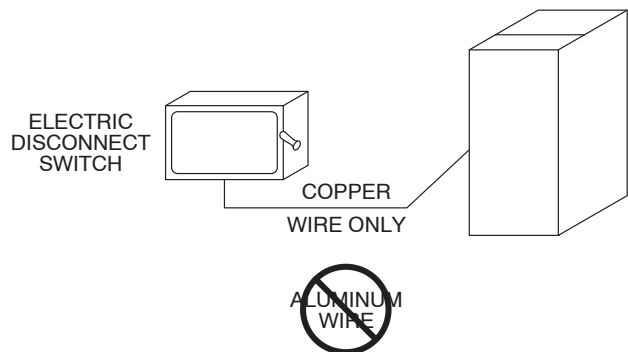

A93033

Fig. 8 - Disconnect Switch and Unit

Units Without Factory-Installed Disconnect —

When installing units, provide a disconnect switch per NEC (National Electrical Code) of adequate size. Disconnect sizing data is provided on the unit informative plate. Locate on unit cabinet or within sight of the unit per

national or local codes. Do not cover unit informative plate if mounting the disconnect on the unit cabinet.

Units with Factory-Installed Disconnect —

The factory-installed option disconnect switch is located in a weatherproof enclosure located under the main control box. The manual switch handle is accessible through an opening in the access panel.

All Units -

All field wiring must comply with NEC and all local codes. Size wire based on MCA (Minimum Circuit Amps) on the unit informative plate. See Fig. 9 for power wiring connections to the unit power terminal block and equipment ground. Maximum wire size is #4 ga AWG per pole.

Provide a ground-fault and short-circuit over-current protection device (fuse or breaker) per NEC Article 440 (or local codes). Refer to unit informative data plate for MOCP (Maximum Over-current Protection) device size.

Units Without Disconnect Option

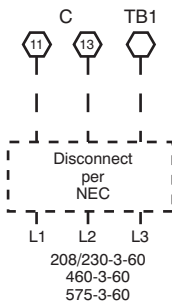

Units With Disconnect Option

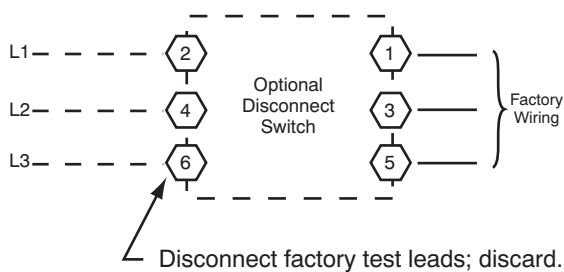

C10204

Fig. 9 - Power Wiring Connections

All units except 208/230-v units are factory wired for the voltage shown on the nameplate. If the 208/230-v unit is to be connected to a 208-v power supply, the control transformer must be rewired by moving the black wire with the 1/4-in. female spade connector from the 230-v connection and moving it to the 208-v 1/4-in. male terminal on the primary side of the transformer. Refer to unit label diagram for additional information.

All field wiring must comply with the NEC and local requirements.

Voltage and Current Balance —

Voltage to compressor terminals during operation must be within voltage range indicated on unit nameplate. See

Table 8. On 3-phase units, voltages between phases must be balanced within 2% and the current within 10%. Use the formula shown in the legend for Table 8, Note 5 (see page 17) to determine the percent of voltage imbalance. Operation on improper line voltage or excessive phase imbalance constitutes abuse and may cause damage to electrical components. Such operation would invalidate any applicable Carrier warranty.

Convenience Outlets

⚠ WARNING

ELECTRICAL OPERATION HAZARD

Failure to follow this warning could result in personal injury or death.

Units with convenience outlet circuits may use multiple disconnects. Check convenience outlet for power status before opening unit for service. Locate its disconnect switch, if appropriate, and open it. Tag-out this switch, if necessary.

38AUQ

Two types of convenience outlets are offered on 38AUQ models: Non-powered and unit-powered. Both types provide a 125-volt GFCI (ground-fault circuit-interrupter) duplex receptacle rated at 15-A behind a hinged waterproof access cover, located on the end panel of the unit. See Fig. 10.

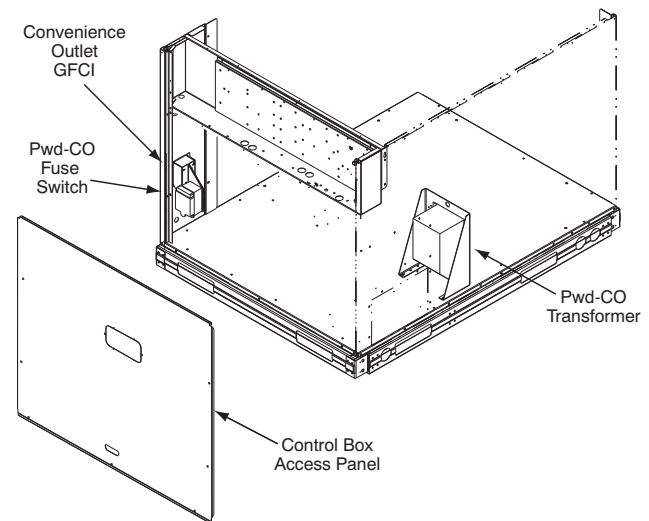

C11038

Fig. 10 - Convenience Outlet Location

Non-powered type: This type requires the field installation of a general-purpose 125-volt 15-A circuit powered from a source elsewhere in the building. Observe national and local codes when selecting wire size, fuse or breaker requirements and disconnect switch size and location. Route 125-v power supply conductors into the bottom of the utility box containing the duplex receptacle.

Unit-powered type: A unit-mounted transformer is factory-installed to stepdown the main power supply voltage to the unit to 115-v at the duplex receptacle. This option also includes a manual switch with fuse, located in

a utility box and mounted on a bracket behind the convenience outlet; access is through the unit's control box access panel. See Fig. 10.

The primary leads to the convenience outlet transformer are not factory-connected. Selection of primary power source is a customer-option. If local codes permit, the transformer primary leads can be connected at the line-side terminals on the unit-mounted non-fused disconnect or HACR breaker switch; this will provide service power to the unit when the unit disconnect switch or HACR switch is open. Other connection methods will result in the convenience outlet circuit being de-energized when the unit disconnect or HACR switch is open. See Fig. 11.

Duty Cycle: The unit-powered convenience outlet has a duty cycle limitation. The transformer is intended to provide power on an intermittent basis for service tools, lamps, etc; it is not intended to provide 15-amps loading for continuous duty loads (such as electric heaters for overnight use). Observe a 50% limit on circuit loading above 8-amps (i.e., limit loads exceeding 8-amps to 30 minutes of operation every hour).

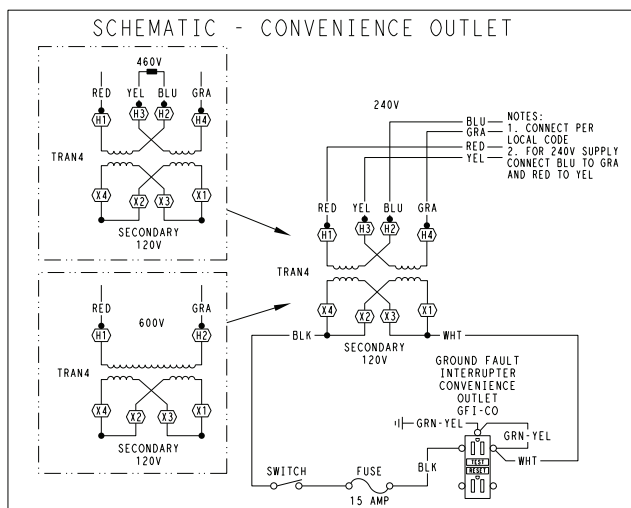

C10206

UNIT VOLTAGE	CONNECT AS	PRIMARY CONNECTIONS	TRANSFORMER TERMINALS
208, 230	240	L1: RED + YEL L2: BLU + GRA	H1 + H3 H2 + H4
460	480	L1: RED Splice BLU + YEL L2: GRA	H1 H2 + H3 H4
575	600	L1: RED L2: GRA	H1 H2

Fig. 11 - Powered Convenience Outlet Wiring

Test the GFCI receptacle by pressing the TEST button on the face of the receptacle to trip and open the receptacle. Check for proper grounding wires and power line phasing if the GFCI receptacle does not trip as required. Press the RESET button to clear the tripped condition.

Fuse on power type: The factory fuse is a Bussman "Fusetron" T-15, non-renewable screw-in (Edison base) type plug fuse.

Using unit-mounted convenience outlets: Units with unit-mounted convenience outlet circuits will often require that two disconnects be opened to de-energize all power to the unit. Treat all units as electrically energized until the convenience outlet power is also checked and de-energization is confirmed. Observe National Electrical Code Article 210, Branch Circuits, for use of convenience outlets.

Installing Weatherproof Cover

A weatherproof while-in-use cover for the factory installed convenience outlets is now required by UL standards. This cover cannot be factory mounted due its depth; it must be installed at unit installation. For shipment, the convenience outlet is covered with a blank cover plate.

The weatherproof cover kit is shipped in the unit's control box. The kit includes the hinged cover, a backing plate and gasket.

DISCONNECT ALL POWER TO UNIT AND CONVENIENCE OUTLET.

Remove the blank cover plate at the convenience outlet; discard the blank cover.

Loosen the two screws at the GFCI duplex outlet, until approximately 1/2 in (13 mm) under screw heads are exposed. Press the gasket over the screw heads. Slip the backing plate over the screw heads at the keyhole slots and align with the gasket; tighten the two screws until snug (do not overtighten).

Mount the weatherproof cover to the backing plate as shown in Fig. 12. Remove two slot fillers in the bottom of the cover to permit service tool cords to exit the cover. Check for full closing and latching.

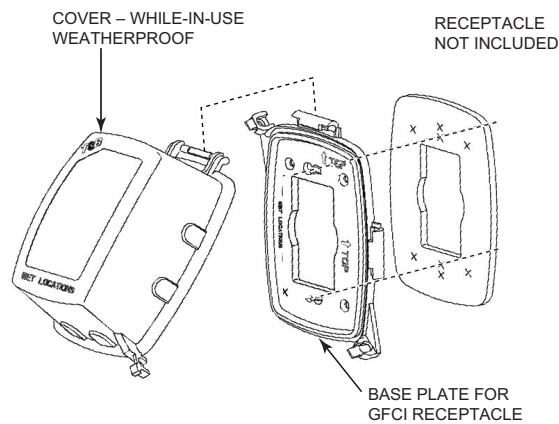

C09022

Fig. 12 - Weatherproof Cover Installation

NOTE: Check all factory and field electrical connections for tightness.

Field Control Wiring —

38AUQ unit control voltage is 24 v. See Figs. 21 - 23 for typical field control connections and the unit's label diagram for field-supplied wiring details. Route control wires to the 38AUQ unit through the opening in unit's end panel to the connections terminal board in the unit's control box.

Remainder of the system controls connection will vary according to the specific construction details of the indoor section. Fig. 13 depicts typical connections to a Carrier 40RUQ fan coil unit. Plan for field connections carefully and install control wiring correctly per the project plan. Additional components and supplemental transformer accessory may be required.

The 38AUQ unit requires an external temperature control device. This device can be a thermostat (field-supplied) or a PremierLink controller (available as a field-installed accessory, for use on a Carrier Comfort Network or as a stand alone control).

Thermostat —

Install a Carrier-approved accessory thermostat according to installation instructions included with the accessory. For complete economizer function, select a two-stage cooling thermostat. 38AUQ(D,E) units require a two-stage thermostat.

38AUQ unit control system requires a conventional electric thermostat that will energize the G terminal on a call for Cool and Heat mode. Do not configure the thermostat a heat pump type; Heat mode will not work with a thermostat configured for heat pump.

Locate the thermostat accessory on a solid wall in the conditioned space to sense average temperature in accordance with the thermostat installation instructions.

If the thermostat contains a logic circuit requiring 24-v power, use a thermostat cable or equivalent single leads of different colors with minimum of five leads between the 38AUQ unit's outdoor unit connection board and the indoor unit connection board. If the thermostat does not require a 24-v source (no "C" connection required), use a thermostat cable or equivalent with minimum of four leads. One additional lead is required between the indoor unit connection board and the thermostat for terminal G. If the accessory electric heat is used, one additional wire is required between the indoor unit connection board and the thermostat for terminal W2. Check the thermostat installation instructions for additional features which might require additional conductors in the cable.

NOTE: Two-stage units require an additional wire for the Y2 connection.

For wire runs up to 50 ft. (15 m), use no. 18 AWG (American Wire Gage) insulated wire (35°C minimum). For 50 to 75 ft. (15 to 23 m), use no. 16 AWG insulated wire (35°C minimum). For over 75 ft. (23 m), use no. 14 AWG insulated wire (35°C minimum). All wire sizes larger than no. 18 AWG cannot be directly connected to the thermostat and will require a junction box and splice at the thermostat.

PremierLink (accessory installation) – Refer to Form 33CS-68SI (or later) for details on connecting the PremierLink controller and its various sensors.

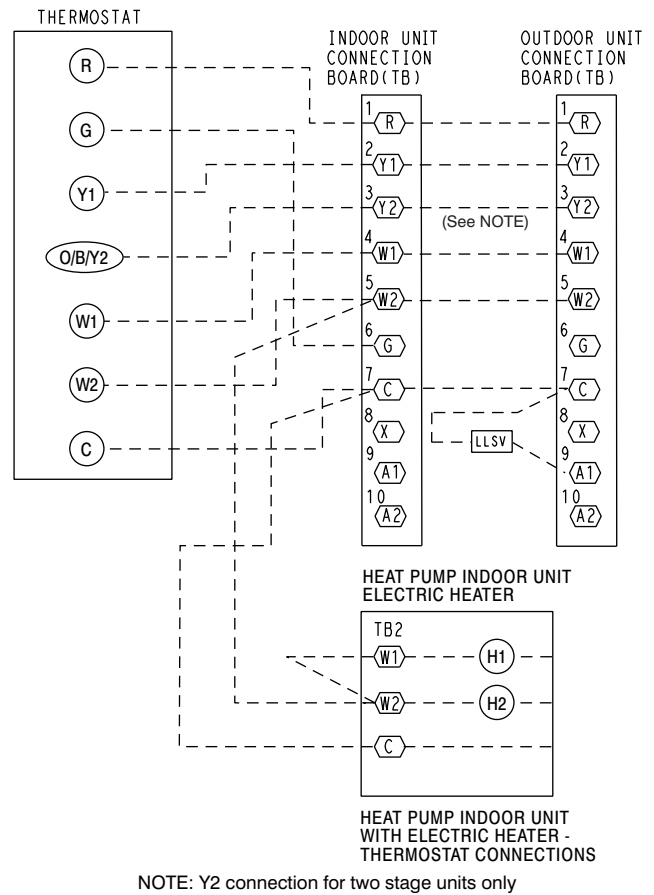

NOTE: Y2 connection for two stage units only

C150420

Fig. 13 - Typical Remote Thermostat Connections

External Control Devices —

The 38AUQ control transformers provide 24-v NEC Class 2 power sources to energize external control devices. These devices will include the indoor fan motor contactor (or control relay). These devices may also include a liquid line solenoid valve, economizer control relay, supplemental electric heater contactors or control relays and other devices selected by system designer.

Control transformer TRAN1 provides control power through terminal R to C on the 38AUQ's outdoor unit field connection terminal strip for supply fan motor interlock. This source may also be used to energize economizer control relay and electric heater contactors or relays. Maximum available power is 50 va. Check concurrent loadings by external control devices. If the maximum concurrent loading exceeds 50 va, purchase and install the accessory Transformer-Relay package (available for 208/230 and 460-v units).

Control transformer TRAN2 provides control power through terminal A1 (9) to C for the liquid line solenoid. Maximum available power is 15 va. This output is switched ON/OFF by the Solenoid Valve Relay (field-supplied, use Carrier Service Part PNO HN61PC005).

38AUQ

Table 8 – Electrical Data — 38AUQ*07-12 60 Hz Units

38AUQ

UNIT	NOMINAL POWER SUPPLY	VOLTAGE RANGE [‡]		COMPRESSOR				WITHOUT POWERED CONVENIENCE OUTLET					
				No. 1		No. 2		OFM (ea)		POWER SUPPLY		DISCONNECT SIZE	
	V-Ph-Hz	MIN	MAX	RLA	LRA	RLA	LRA	QTY	FLA	MCA	Fuse or HACR Brkr	FLA	LRA
38AUQA/B07 Units produced on or after 02/09/2015	208/230-3-60	187	253	19.6	136	-	-	2	1.5	28/28	45/45	26/26	142/142
	460-3-60	414	506	8.2	66	-	-	2	0.8	12	20	11	70
	575-3-60	518	633	6.6	55	-	-	2	0.7	10	15	9	59
38AUQA/B*07 Units produced on or prior to 02/08/2015	208/230-3-60	187	253	19.0	123	-	-	2	1.5	26.8/26.8	45/45	25/25	129/129
	460-3-60	414	506	9.7	62	-	-	2	0.8	13.7	20	13	66
	575-3-60	518	633	7.4	50	-	-	2	0.7	10.7	15	10	54
38AUQD/E*07	208/230-3-60	187	253	17.5	136	-	-	2	1.5	25/25	30/30	24/24	142/142
	460-3-60	414	506	8.4	66	-	-	2	0.8	13	20	12	70
	575-3-60	518	633	6.3	55	-	-	2	0.7	10	15	9	59
38AUQ*08	208/230-3-60	187	253	25.2	164	-	-	2	1.5	35/35	50/50	32/32	170/170
	460-3-60	414	506	12.7	100	-	-	2	0.8	18	30	16	104
	575-3-60	518	633	11.0	78	-	-	2	0.7	16	25	14	82
38AUQA/B12	208/230-3-60	187	253	30.8	225	-	-	2	1.5	42/42	60/60	39/39	231/231
	460-3-60	414	506	16.7	114	-	-	2	0.8	23	30	21	118
	575-3-60	518	633	12.8	80	-	-	2	0.7	18	30	16	84
38AUQD/E12	208/230-3-60	187	253	15.9	110	15.6	110	2	1.5	39/39	50/50	40/40	226/226
	460-3-60	414	506	7.7	52	7.7	52	2	0.8	19	25	20	108
	575-3-60	518	633	5.7	39	5.8	39	2	0.7	15	20	15	82

UNIT	NOMINAL POWER SUPPLY	VOLTAGE RANGE [‡]		COMPRESSOR				WITH POWERED CONVENIENCE OUTLET					
				No. 1		No. 2		OFM (ea)		POWER SUPPLY		DISCONNECT SIZE	
	V-Ph-Hz	MIN	MAX	RLA	LRA	RLA	LRA	QTY	FLA	MCA	Fuse or HACR Brkr	FLA	LRA
38AUQA/B07 Units produced on or after 02/09/2015	208/230-3-60	187	253	19.6	136	-	-	2	1.5	33/33	50/50	32/32	147/147
	460-3-60	414	506	8.2	66	-	-	2	0.8	15	20	14	72
	575-3-60	518	633	6.6	55	-	-	2	0.7	12	15	11	61
38AUQA/B07 Units produced on or prior to 02/08/2015	208/230-3-60	187	253	19.0	123	-	-	2	1.5	31.6/31.6	50/50	31/31	134/134
	460-3-60	414	506	9.7	62	-	-	2	0.8	15.9	25	16	68
	575-3-60	518	633	7.4	50	-	-	2	0.7	12.4	15	12	56
38AUQD/E07	208/230-3-60	187	253	17.5	136	-	-	2	1.5	30/30	45/45	29/29	147/147
	460-3-60	414	506	8.4	66	-	-	2	0.8	15	20	14	72
	575-3-60	518	633	6.3	55	-	-	2	0.7	11	15	11	61
38AUQ*08	208/230-3-60	187	253	25.2	164	-	-	2	1.5	40/40	60/60	38/38	175/175
	460-3-60	414	506	12.7	100	-	-	2	0.8	20	30	19	106
	575-3-60	518	633	11.0	78	-	-	2	0.7	17	25	16	84
38AUQA/B12	208/230-3-60	187	253	30.8	225	-	-	2	1.5	47/47	60/60	44/44	236/236
	460-3-60	414	506	16.7	114	-	-	2	0.8	25	30	24	120
	575-3-60	518	633	12.8	80	-	-	2	0.7	20	30	18	86
38AUQD/E12	208/230-3-60	187	253	15.9	110	15.6	110	2	1.5	44/44	50/50	45/45	231/231
	460-3-60	414	506	7.7	52	7.7	52	2	0.8	22	25	22	110
	575-3-60	518	633	5.7	39	5.8	39	2	0.7	17	20	17	84

Legend and Notes for Table 8

LEGEND:

- BRKR - Circuit breaker
- CO - Convenient outlet
- FLA - Full Load Amps
- LRA - Locked Rotor Amps
- MCA - Minimum Circuit Amps Protection
- NEC - National Electrical Code
- PWRD CO - Powered convenient outlet
- RLA - Rated Load Amps
- UNPWR CO - Unpowered convenient outlet



NOTES:

1. In compliance with NEC requirements for multimotor and combination load equipment (refer to NEC Articles 430 and 440), the overcurrent protective device for the unit shall be fuse or HACR breaker. Canadian units may be fuse or circuit breaker.
2. The MCA values are calculated in accordance with The NEC. Article 440.
3. Motor RLA and LRA values are established in accordance with Underwriters' Laboratories (UL). Standard 1995.
4. The 575-v units are UL, Canada-listed only.
5. **Unbalanced 3-Phase Supply Voltage**
Never operate a motor where a phase imbalance in supply voltage is greater than 2%. Use the following formula to determine the percentage of voltage imbalance.

Example: Supply voltage is 230-3-60

$$\% \text{ Voltage Imbalance} = 100 \times \frac{\text{max voltage deviation from average voltage}}{\text{average voltage}}$$



AB = 224 v
BC = 231 v
AC = 226 v

$$\text{Average Voltage} = \frac{(224 + 231 + 226)}{3} = \frac{681}{3} = 227$$

Determine maximum deviation from average voltage.

(AB) 227 - 224 = 3 v

(BC) 231 - 227 = 4 v

(AC) 227 - 226 = 1 v

Maximum deviation is 4 v.

Determine percent of voltage imbalance.

$$\% \text{ Voltage Imbalance} = 100 \times \frac{4}{227} = 1.76\%$$

This amount of phase imbalance is satisfactory as it is below the maximum allowable 2%.

IMPORTANT: If the supply voltage phase imbalance is more than 2%, contact your local electric utility company immediately.

38AUQ

Step 8 — Wind Baffles for Low Ambient Control

38AUQB and 38AUQE units includes the factory installed 32LT Motormaster Low Ambient Control.

Units with 32LT Motormaster control require the addition of wind baffles to ensure full range low ambient operation. Material data and dimensions for wind baffles are included in the Appendix C section, Low Ambient Control, starting on page 47. Fabricate the wind baffles and mount per instructions.

PRE-START-UP

IMPORTANT: Before beginning Pre-Start-Up or Start-Up, review Start-Up Checklist at the back of this book. The Checklist assures proper start-up of a unit and provides a record of unit condition, application requirements, system information, and operation at initial start-up.

⚠ CAUTION

UNIT DAMAGE HAZARD

Failure to follow this caution may result in equipment damage.

Do not attempt to start the heat pump system, even momentarily, until the following steps have been completed. Compressor damage may result.

System Check

1. Check all indoor section and other equipment auxiliary components. Consult the manufacturer's instructions regarding any other equipment connected to the condensing unit. If the unit has field-installed accessories, be sure all are properly installed and correctly wired. If used, the airflow switch must be properly installed.
2. Be sure the unit is properly leak checked and dehydrated.
3. Check tightness of all electrical connections.
4. Open the liquid line and suction line service valves.
5. Be sure the unit is properly charged. See "Preliminary Charge", below.
6. The electrical power source must agree with the unit's nameplate rating.
7. The crankcase heater must be firmly attached to the compressor crankcase. Be sure the crankcase is warm (heater must be on for 24 hours before starting compressor).

Turn On Crankcase Heater

Turn on the crankcase heater for 24 hours before starting the unit to be sure all the refrigerant is out of the oil. To energize the crankcase heater, proceed as follows:

1. Set the space thermostat set point above the space temperature so there is no demand for cooling.
2. Close the field disconnect.

Preliminary Charge

Before starting the unit, charge liquid refrigerant into the high side of the system through the liquid service valve. The amount of refrigerant added must be at least 80% of the operating charge listed in the Physical Data table (Tables 1A and 1B on pages 5 and 6). Allow high and low side pressures to equalize before starting compressor. If pressures do not equalize readily, charge vapor on low side of system to assure charge in the evaporator. Refer to GTAC II, Module 5, Charging, Recover, Recycling, and Reclamation for liquid charging procedures.

⚠ CAUTION

UNIT DAMAGE HAZARD

Failure to follow this caution may result in equipment damage.

Prior to starting compressor, a preliminary charge of refrigerant must be added to avoid possible compressor damage.

START-UP

38AUQ Units

The compressor crankcase heater must be on for 24 hours before start-up. After the heater has been on for 24 hours, the unit can be started. If no time elapsed since the preliminary charge step was completed, it is unnecessary to wait the 24-hour period.

Preliminary Checks —

1. Check that electric power supply agrees with unit nameplate data.
2. Verify that the compressor crankcase heater is securely in place.
3. Check that the compressor crankcase heater has been on at least 24 hours.
4. Recheck for leaks using the procedure outlined in the Pre-Start-Up section, Leak Test and Dehydration. If any leaks are detected, repair as required. Evacuate and dehydrate as described in the Leak Test and Dehydration section.
5. Ensure that the preliminary charge has been added as described in the Pre-Start-Up section, Preliminary Charge.
6. All internal wiring connections must be tight, and all barriers and covers must be in place.

NOTE: The units are factory charged with the required amount of oil. If recharging is required, use Emkarate RL 32-3MAF.

Compressor Rotation —

On 3-phase units with scroll compressors, it is important to be certain that the compressor is rotating in the proper direction. 38AUQ units are equipped with a Comfort Alert Diagnostic Module (CADM). Alert Code 7 indicates reverse power phasing.

To correct phase order:

1. Turn off power to the unit, tag disconnect.
2. Reverse any two of the unit power leads.
3. Reapply power to the compressor, verify correct pressures.

To verify the compressor is rotating in the proper direction:

1. Connect service gages to the suction and liquid pressure fittings.
2. Energize the compressor.
3. The suction pressure should drop and the liquid pressure should rise, as is normal on any start-up.

Compressor Overload —

This overload interrupts power to the compressor when either the current or internal motor winding temperature becomes excessive, and automatically resets when the internal temperature drops to a safe level. This overload may require up to 60 minutes (or longer) to reset. If the internal overload is suspected of being open, disconnect the electrical power to the unit and check the circuit through the overload with an ohmmeter or continuity tester.

Advanced Scroll Temperature Protection (ASTP) —

A label located above the terminal box identifies Copeland Scroll compressor models that contain this technology. See Fig. 14. Advanced Scroll Temperature Protection (ASTP) is a form of internal discharge temperature protection, that unloads the scroll compressor when the internal temperature reaches approximately 300°F. At this temperature, an internal bi-metal disk valve opens and causes the scroll elements to separate, which stops compression. Suction and discharge pressures balance while the motor continues to run. The longer the compressor runs unloaded, the longer it must cool before the bi-metal disk resets. See Fig. 15.



C10080

Fig. 14 - Advanced Scroll Temperature Protection Label

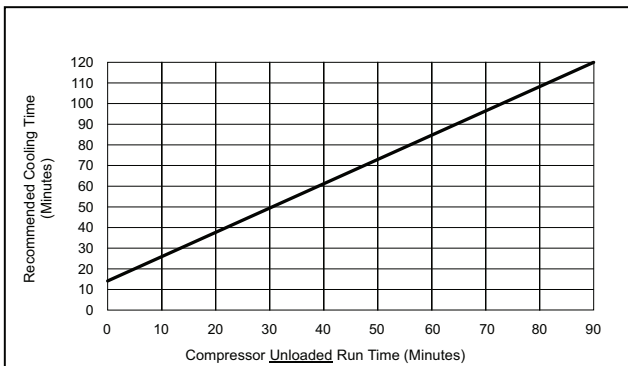

*Times are approximate.

NOTE: Various factors, including high humidity, high ambient temperature, and the presence of a sound blanket will increase cool-down times.

C10081

Fig. 15 - Recommended Minimum Cool-Down Time After Compressor is Stopped

To manually reset ASTP, the compressor should be stopped and allowed to cool. If the compressor is not stopped, the motor will run until the motor protector trips, which occurs up to 90 minutes later. Advanced Scroll Temperature Protection will reset automatically before the motor protector resets, which may take up to 2 hours.

Start Unit —

Disconnect the field low voltage lead at the 38AUQ unit's R terminal to prevent compressor operation. Close the 38AUQ disconnect switch. Only the crankcase heater will be energized.

Reconnect the field low voltage lead to the 38AUQ unit's R terminal. Adjust thermostat setting for Cool below space temperature.

⚠ **CAUTION**

UNIT DAMAGE HAZARD

Failure to follow this caution may result in equipment damage.

Never charger liquid into the low-pressure side of the system. Do not overcharge. During charging or removal of refrigerant, be sure indoor-fan system is operating. Ensure both outdoor fan motors re running; bypass any Motormaster function.

38AUQ

Adjust Refrigerant Charge —

The unit must be charged in Cooling mode only. Refer to Cooling Charging Charts, Fig. 16 through Fig. 20. For applications with line lengths greater than 100 ft, contact Carrier representative. Vary refrigerant until the conditions of the chart are met. The charts are based on charging the units to the correct subcooling for the various operating conditions. Accurate pressure gage and temperature sensing device are required. Connect the pressure gage to the service port on the liquid line service valve. Mount the temperature sensing device on the liquid line close to the liquid line service valve, and insulate it so that outdoor ambient temperature does not affect the reading. Indoor airflow must be within the unit's normal operating range. Operate the unit for a minimum of 15 minutes. Ensure that pressure and temperature readings have stabilized. Plot the liquid pressure and temperature on chart and add or reduce the charge to meet the curve. Adjust the charge to conform with the charging chart, using the liquid pressure and temperature to read the chart.

Final Checks —

Ensure that all safety controls are operating, control panel covers are on, and the service panels are in place.

38AUQ

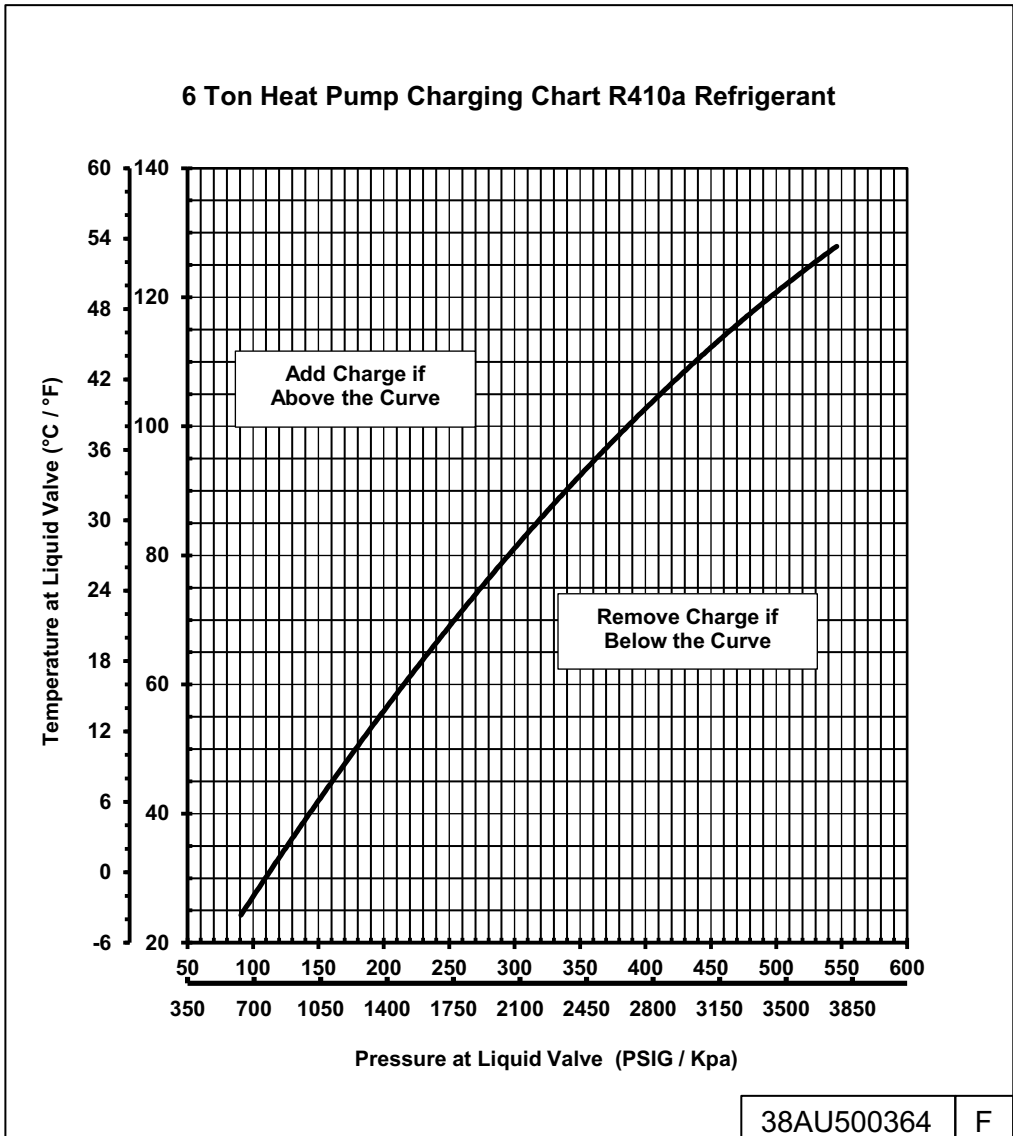
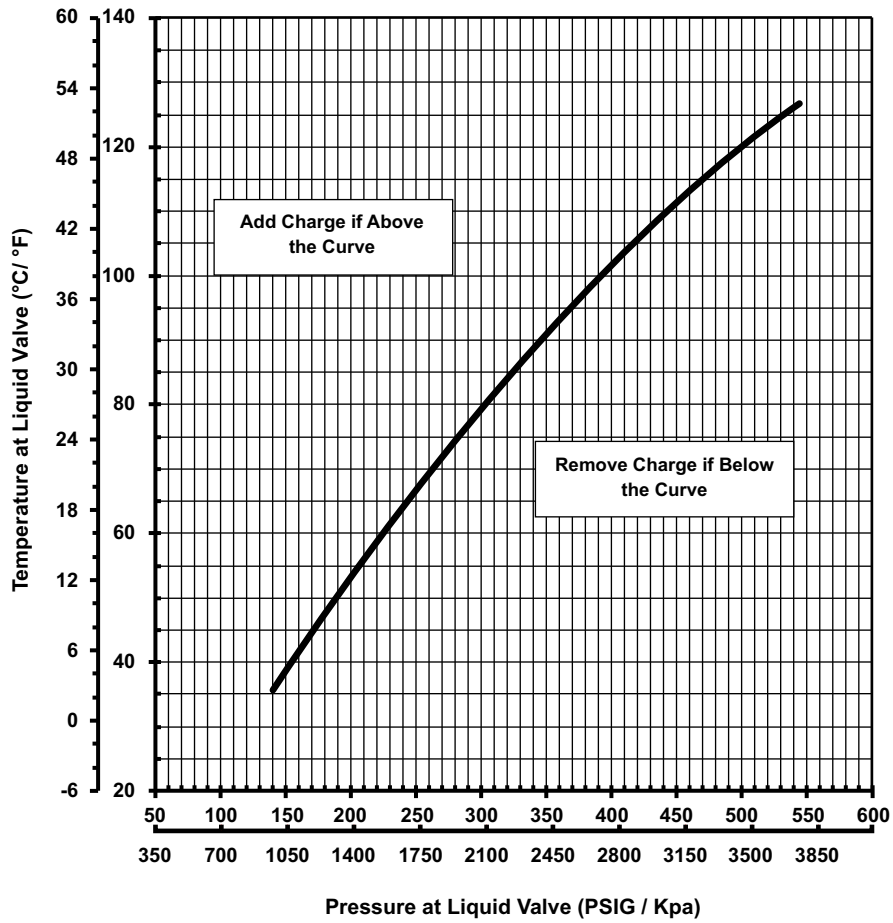

Fig. 16 - 38AUQA/B07 Charging Chart

C150421

**6 TON HEAT PUMP DUAL STAGE CHARGING CHART PURON
(COMPRESSOR FULL LOAD, ALL CONDENSER FANS OPERATING)**



PN: 38AU000485 REV -

38AUG

Fig. 17 - 38AUQD/E07 Charging Chart

C150343

38AUQ

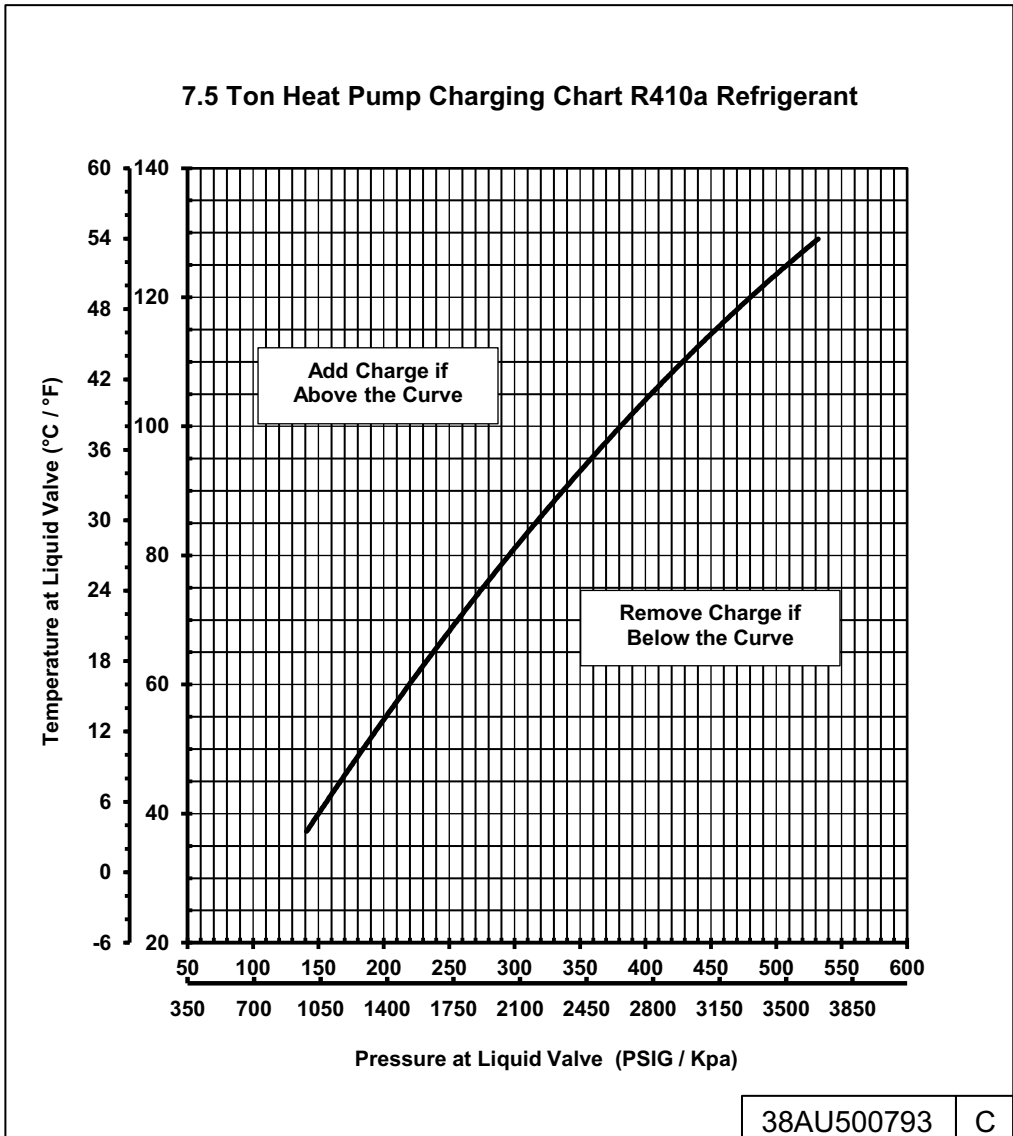
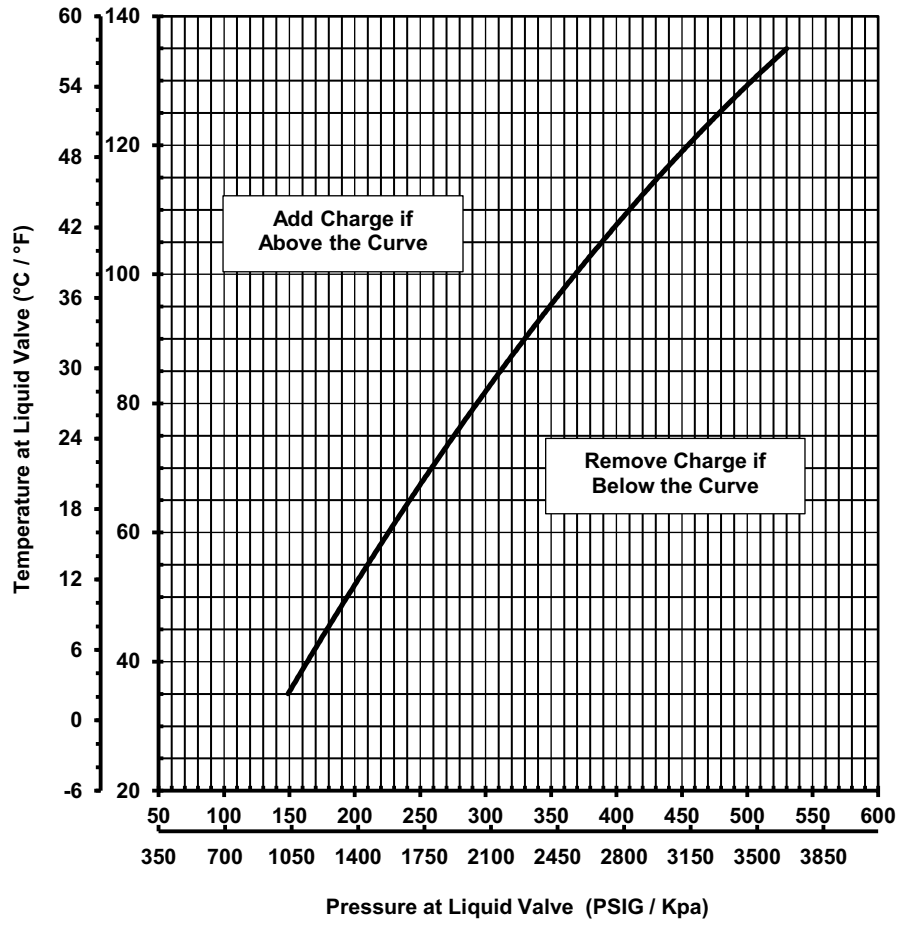

Fig. 18 - 38AUQ*08 Charging Chart

C150422

10 Ton Heat Pump Charging Chart R410a Refrigerant



38AU500794 C

38AUQ

Fig. 19 - 38AUQA/B*12 Charging Chart

C150423

**10 TON HEAT PUMP DUAL STAGE CHARGING CHART PURON
(COMPRESSOR FULL LOAD, ALL CONDENSER FANS OPERATING)**

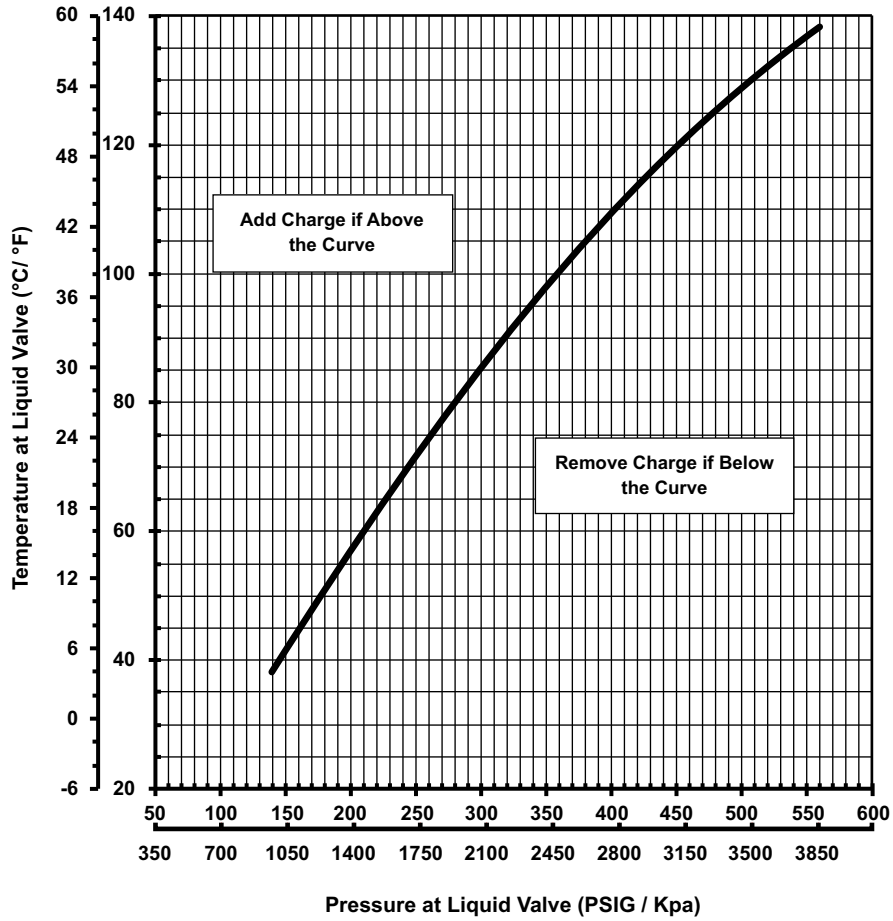

PN: 38AU000486 REV -

Fig. 20 - 38AUQD/E*12 Charging Chart

C150344

38AUQ

SCHEMATIC
208/230V 6,7.5,10T SNGL HP

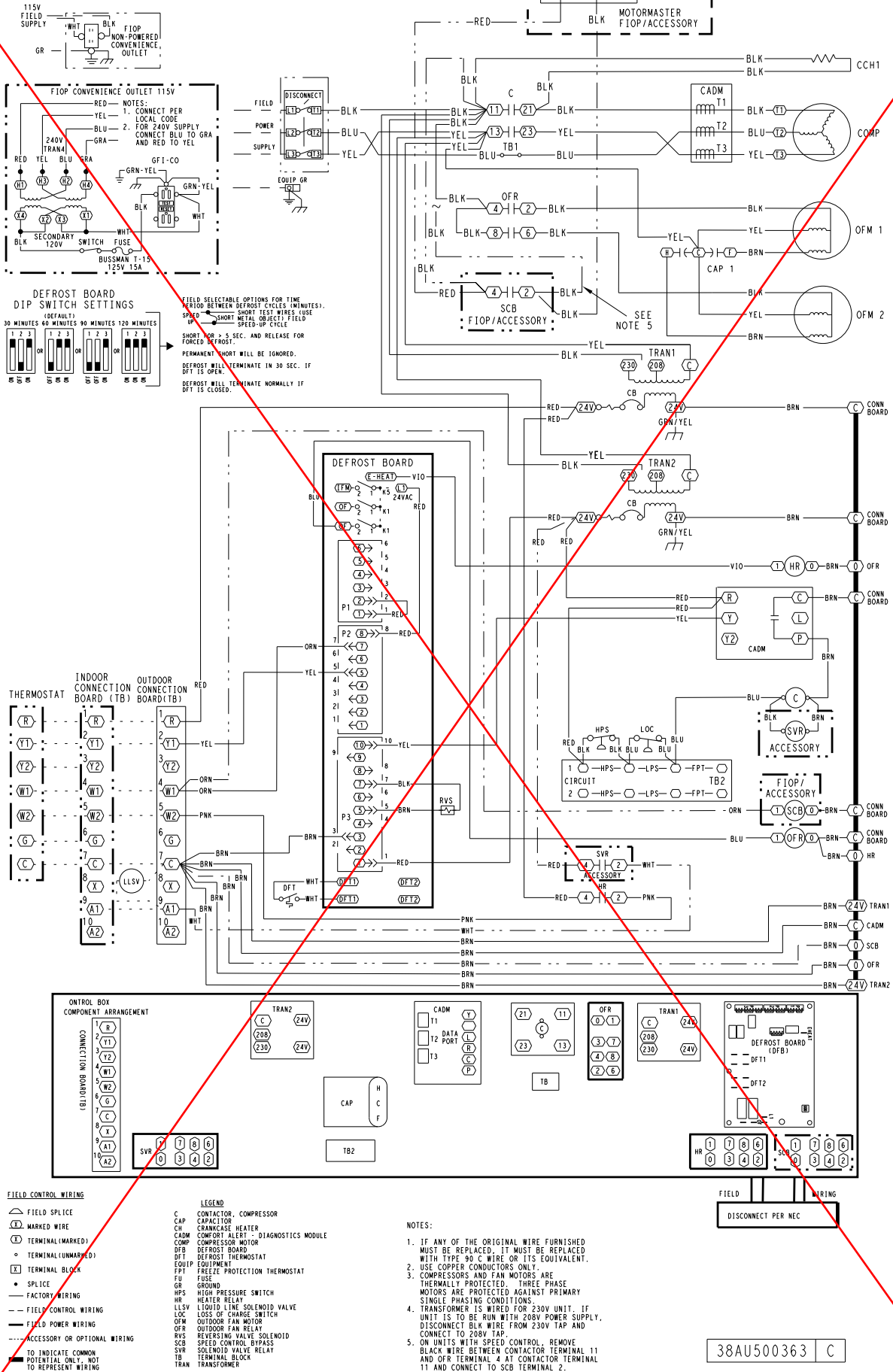

38AUQ

Fig. 21 - 38AUQA/B07-12 Single Circuit / Single Stage Wiring Diagram (208/230-3-60 shown)

SCHEMATIC
208/230, 460V 6T 2-STG HP

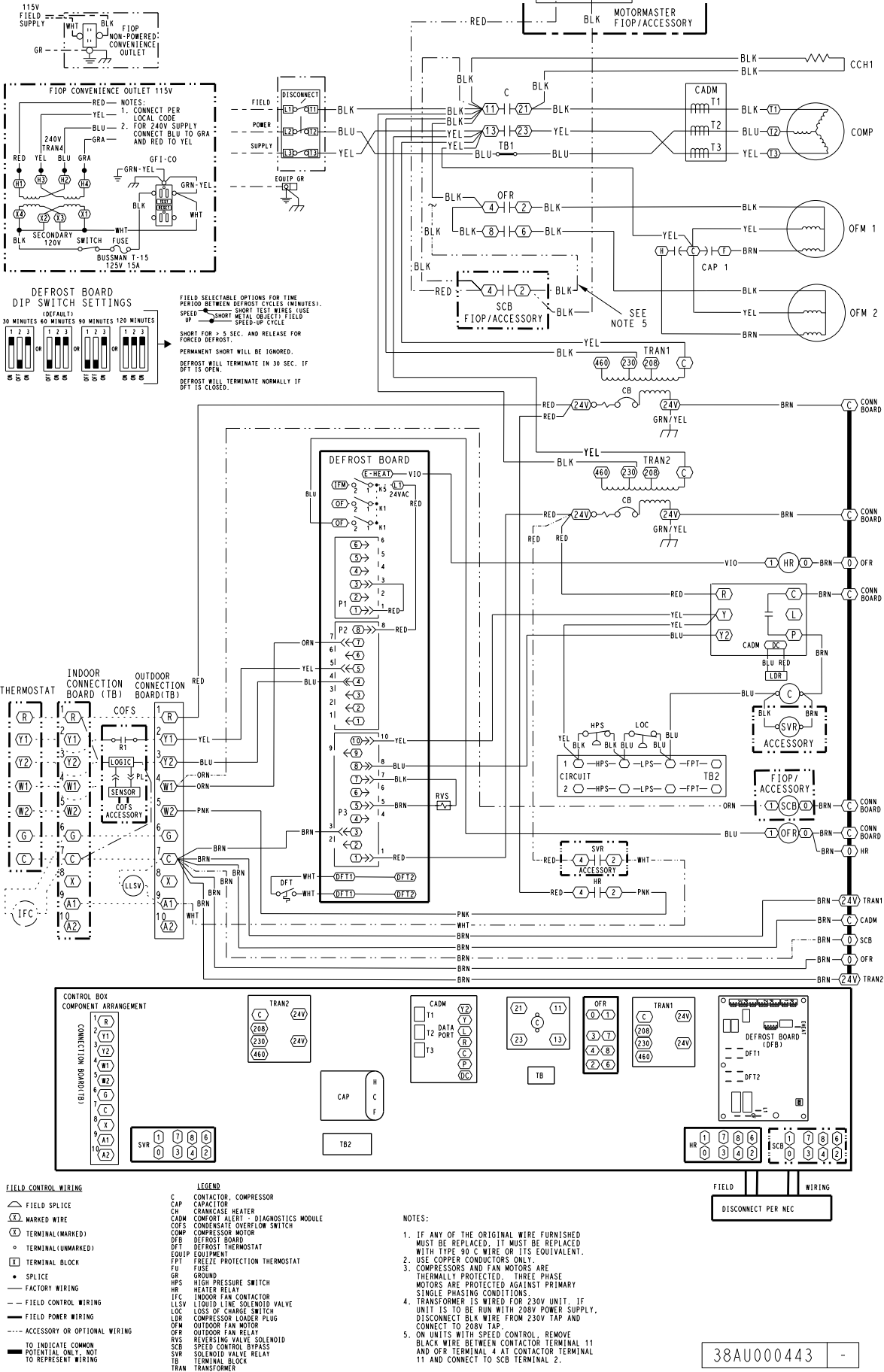

38AUQ

Fig. 22 - 38AUQD/E07 Single Circuit / Two Stage Wiring Diagram (208/230, 460-3-60 shown)

SCHEMATIC
208/230, 460V 10T 2-STG HP

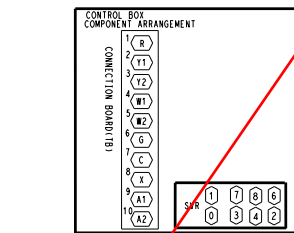
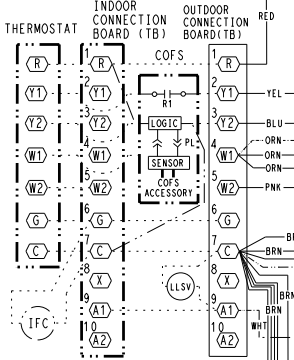
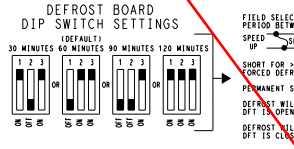
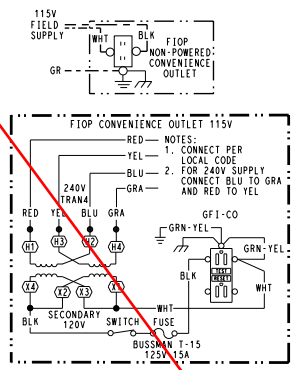
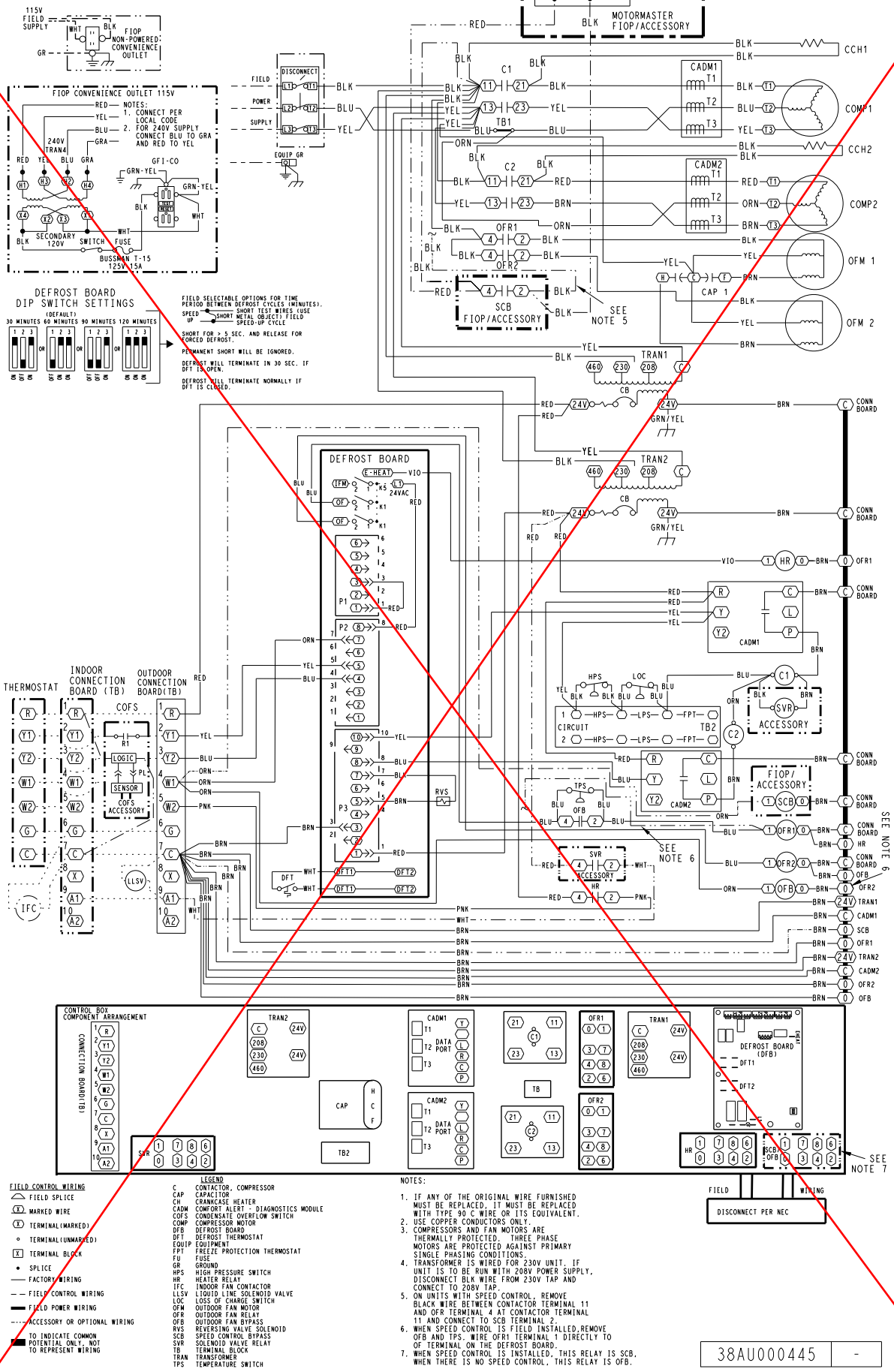

- FIELD CONTROL WIRING**
- △ FIELD SPlice
 - MARKED WIRE
 - ⊗ TERMINAL (MARKED)
 - TERMINAL (UNMARKED)
 - ⊗ TERMINAL (BLACK)
 - SPlice
 - FACTORY WIRING
 - - - FIELD CONTROL WIRING
 - FIELD POWER WIRING
 - - - ACCESSORY OR OPTIONAL WIRING
 - TO INDICATE COMMON POTENTIAL ONLY, NOT TO REPRESENT WIRING
- LEGEND**
- C CONTACTOR, COMPRESSOR
 - CAP CAPACITOR
 - CH CRANKCASE HEATER
 - CADM COMFORT ALERT - DIAGNOSTICS MODULE
 - COFS CONDENSATE OVERTLOW SWITCH
 - COMP COMPRESSOR MOTOR
 - DFB DEFROST BOARD
 - DFT DEFROST THERMOSTAT
 - EQUIP EQUIPMENT
 - FPT FREEZE PROTECTION THERMOSTAT
 - FU FUSE
 - GR GROUND
 - HPS HIGH PRESSURE SWITCH
 - HR HEATER RELAY
 - IFC INDOOR FAN CONTACTOR
 - OFM OUTDOOR FAN MOTOR
 - LLSV LIQUID LINE SOLENOID VALVE
 - LOC LOSS OF CHARGE SWITCH
 - OFB OUTDOOR FAN RELAY
 - OFB OUTDOOR FAN BYPASS
 - RVS REVERSING VALVE SOLENOID
 - SCB SPEED CONTROL BYPASS
 - SVR SPEED CONTROL VALVE RELAY
 - TB TERMINAL BLOCK
 - TRAN TRANSFORMER
 - TPS TEMPERATURE SWITCH

- NOTES:**
1. IF ANY OF THE ORIGINAL WIRE FURNISHED MUST BE REPLACED, IT MUST BE REPLACED WITH TYPE 90 C WIRE OR ITS EQUIVALENT.
 2. USE COPPER CONDUCTORS ONLY.
 3. COMPRESSORS AND FAN MOTORS ARE THERMALLY PROTECTED. THREE PHASE MOTORS ARE PROTECTED AGAINST PRIMARY SINGLE PHASING CONDITIONS.
 4. TRANSFORMER IS WIRED FOR 230V UNIT. IF UNIT IS TO BE RUN WITH 208V POWER SUPPLY, DISCONNECT BLK WIRE FROM 230V TAP AND CONNECT TO 208V TAP.
 5. ON UNITS WITH SPEED CONTROL, REMOVE BLACK WIRE BETWEEN CONTACTOR TERMINAL 11 AND OFR TERMINAL 4 AT CONTACTOR TERMINAL 11 AND CONNECT TO SCB TERMINAL 2.
 6. WHEN SPEED CONTROL IS FIELD INSTALLED, REMOVE OFB AND TPS. WIRE OFR1 TERMINAL 1 DIRECTLY TO OFR TERMINAL ON THE DEFROST BOARD.
 7. WHEN SPEED CONTROL IS INSTALLED, THIS RELAY IS SCB. WHEN THERE IS NO SPEED CONTROL, THIS RELAY IS OFB.

38AU000445 -

38AUQ

Fig. 23 - 38AUQD/E12 Single Circuit / Two Stage Wiring Diagram (208/230, 460-3-60 shown)

OPERATING SEQUENCE

Base Unit Controls

Indoor (Supply) Fan —

The indoor fan contactor (IFC) is remotely located at the fan coil or fan section. If the thermostat fan operation is selected as Continuous, the IFC is energized and the indoor (supply) fan motor runs continuously. If the thermostat fan operation is selected as Automatic, the IFC will be energized on a call for Cooling or Heating; indoor (supply) fan motor runs. When thermostat is satisfied, the IFC is de-energized and indoor (supply) fan motor stops.

Cooling, Unit Without Economizer - Single Stage Units—

When thermostat calls for Cooling, terminal Y1 is energized. The 38AUQ's Defrost Board (DFB) receives this input at P2-5. DFB issues 24-v outputs at OF, P3-7 (RVS1) and P3-10 (COMP1). The OF output energizes outdoor fan relay (OFR); both outdoor fan motors start and run. The output RVS1 energizes the reversing valve solenoid (RVS); Reversing valve switches to Cooling position.

Output PL3-10 (COMP1, 24-v) is received at CADM terminal Y. If anti-recycle time delay period has not expired, safety pressure switches are open, and/or lockout alarms are active, CADM relay will remain open, preventing compressor start. When safety pressure switches are closed and CADM time delay expires, the CADM relay closes, energizing Solenoid Valve Relay SVR and compressor contactor C. SVR contacts close, energizing the external liquid line solenoid valve. Solenoid valve LLSV opens. Compressor contactor C closes, energizing the compressor motor. Compressor starts and system runs in Cooling mode.

When space cooling load is satisfied, terminal Y1 is de-energized. Compressor and outdoor fan motors stop. Liquid line solenoid valve LLSV is de-energized and valve closes. CADM begins its three-minute anti-recycle time delay.

If either the Loss of Charge (LOC) Switch or High Pressure Switch (HPS) opens while Y1 remains energized, the compressor contactor C and relay SVR are de-energized; compressor stops and liquid line solenoid is de-energized (valve closes). CADM initiates a TRIP event (cooling demand sensed at CADM terminal Y but no current is measured at T1, T2, T3 motor sensors); CADM relay opens and RED LED is illuminated. TRIP condition maintains lockout of compressor operation until CADM is manually reset. Reset CADM by cycling unit main power.

Reversing valve solenoid (RVS) is energized in Cooling modes. This solenoid will remain energized until the next Heating mode is initiated.

Cooling, Unit Without Economizer - Two-Stage Units—

For two stage units, the 38AUQ(D,E)07 uses a two-stage Copeland Ultratech Scroll compressor in conjunction with a two-stage Comfort Alert Module (CADM). The

38AUQ(D,E)12 uses two compressors in tandem on a single circuit in conjunction with two single-stage Comfort Alert Modules (CADM).

38AUQ(D,E)07

When thermostat calls for Stage 1 Cooling, terminal Y1 is energized. The 38AUQ's Defrost Board (DFB) receives this input at P2-5. DFB issues 24-v outputs at OF, P3-7 (RVS1) and P3-10 (COMP1). The OF output energizes outdoor fan relay (OFR); both outdoor fan motors start and run. The output RVS1 energizes the reversing valve solenoid (RVS); Reversing valve switches to Cooling position. Output PL3-10 (COMP1, 24-v) is received at CADM terminal Y. If anti-recycle time delay period has not expired, safety pressure switches are open, and/or lockout alarms are active, CADM relay will remain open, preventing compressor start. When safety pressure switches are closed and CADM time delay expires, the CADM relay closes, energizing Solenoid Valve Relay SVR and compressor contactor C. SVR contacts close, energizing the external liquid line solenoid valve. Solenoid valve LLSV opens. Compressor contactor C closes, energizing the compressor motor. Compressor starts and system runs in Stage 1 Cooling mode.

When thermostat calls for Stage 2 Cooling, terminal Y2 is energized. The 38AUQ's Defrost Board (DFB) receives this input at P2-4. DFB issues 24-v outputs at OF, P3-8 (COMP2). Output PL3-8 (COMP2, 24-v) is received at CADM terminal Y2. CADM DC SOL terminal outputs 24-vdc to the compressor loader plug (LDR) and the compressor operates at full load capacity.

As space cooling load is satisfied, thermostat outputs Y2 and Y1 are sequentially de-energized, removing 24-v at terminals Y2 and Y1. Compressor Loader plug is de-energized on Y2 opening. On Y1 opening, the Compressor stops, all outdoor fan motors stop and SVR relay is de-energized. Liquid line solenoid valve is de-energized and valve closes. CADM begins its three-minute anti-recycle time delay.

If either the Loss of Charge (LOC) Switch or High Pressure Switch (HPS) opens while Y1 remains energized, the compressor contactor C and relay SVR are de-energized; compressor stops and liquid line solenoid is de-energized (valve closes). CADM initiates a TRIP event (cooling demand sensed at CADM terminal Y but no current is measured at T1, T2, T3 motor sensors); CADM relay opens and RED LED is illuminated. TRIP condition maintains lockout of compressor operation until CADM is manually reset. Reset CADM by cycling unit main power. Reversing valve solenoid (RVS) is energized in Cooling modes. This solenoid will remain energized until the next Heating mode is initiated.

38AUQ(D,E)12

When thermostat calls for Stage 1 Cooling, terminal Y1 is energized. The 38AUQ's Defrost Board (DFB) receives this input at P2-5. DFB issues 24-v outputs at OF, P3-7 (RVS1) and P3-10 (COMP1). The OF output energizes outdoor fan relay (OFR); both outdoor fan motors start and run. The output RVS1 energizes the reversing valve solenoid (RVS); Reversing valve switches to Cooling

position. Output PL3-10 (COMP1, 24-v) is received at CADM1 terminal Y. If anti-recycle time delay period has not expired, safety pressure switches are open, and/or lockout alarms are active, CADM1 relay will remain open, preventing compressor start. When safety pressure switches are closed and CADM time delay expires, the CADM1 relay closes, energizing Solenoid Valve Relay SVR and compressor contactor C1. SVR contacts close, energizing the external liquid line solenoid valve. Solenoid valve LLSV opens. Compressor contactor C1 closes, energizing the compressor motor. Compressor A1 starts and system runs in Stage 1 Cooling mode.

When thermostat calls for Stage 2 Cooling, terminal Y2 is energized. The 38AUQ's Defrost Board (DFB) receives this input at P2-4. DFB issues 24-v outputs at OF, P3-8 (COMP2). Output PL3-8 (COMP2, 24-v) is received at CADM2 terminal Y. If anti-recycle time delay period has not expired and/or lockout alarms are active, CADM2 relay will remain open, preventing compressor start. When CADM2 time delay expires, the CADM2 relay closes, energizing compressor contactor C2. Compressor contactor C2 closes, energizing the compressor motor. Compressor A2 starts and system runs in Stage 2 Cooling mode.

As space cooling load is satisfied, thermostat outputs Y2 and Y1 are sequentially de-energized, removing 24-v at terminals Y2 and Y1. Compressor A2 is de-energized on Y2 opening. On Y1 opening, Compressor A1 stops, all outdoor fan motors stop and SVR relay is de-energized. Liquid line solenoid valve is de-energized and valve closes. CADM begins its three-minute anti-recycle time delay.

If either the Loss of Charge (LOC) Switch or High Pressure Switch (HPS) opens while Y1 remains energized, the compressor contactor C and relay SVR are de-energized; compressor stops and liquid line solenoid is de-energized (valve closes). CADM initiates a TRIP event (cooling demand sensed at CADM terminal Y but no current is measured at T1, T2, T3 motor sensors); CADM relay opens and RED LED is illuminated. TRIP condition maintains lockout of compressor operation until CADM is manually reset. Reset CADM by cycling unit main power. Reversing valve solenoid (RVS) is energized in Cooling modes. This solenoid will remain energized until the next Heating mode is initiated.

Fan Cycling

The 38AUQ(D,E)12 is equipped with a temperature switch that will shut down one outdoor fan in cooling mode when the outdoor temperature falls below 55°F (13°C) to ensure continuous operation in both stages. The outdoor fan will turn back on when the temperature rises above 60°F (16°C).

Cooling, Unit With Economizer —

Refer to fan coil unit installation instructions and economizer accessory installation instructions for operating sequences when system is equipped with accessory economizer.

Heating —

When the thermostat calls for first stage heating, terminal W1 is energized. The 38AUQ's Defrost Board (DFB) receives this input at P2-7. The DFB removes the output at P3-7 (RVS1); the reversing valve solenoid is de-energized and the reversing valve moves to Heating position.

DFB issues outputs at OF and P3-10 (COMP1). Outdoor fan relay OFR is energized; both outdoor fan motors run.

Output PL3-10 (COMP1, 24-v) is received at CADM terminal Y. If anti-recycle time delay period has not expired, safety pressure switches are open, and/or lockout alarms are active, CADM relay will remain open, preventing compressor start. When safety pressure switches are closed and CADM time delay expires, the CADM relay closes, energizing Solenoid Valve Relay SVR and compressor contactor C. SVR contacts close, energizing the external liquid line solenoid valve. Solenoid valve LLSV opens. Compressor contactor C closes, energizing the compressor motor. Compressor starts and system runs in Heating mode, providing Stage 1 Heat.

When the space heating load is satisfied terminal W1 is de-energized. Compressor and outdoor fan operations stop. Liquid line solenoid LLSV is de-energized and valve closes. CADM begins its three-minute anti-recycle time delay.

If either the Loss of Charge (LOC) Switch or High Pressure Switch (HPS) opens while, the compressor contactor C and relay SVR are de-energized; compressor stops and liquid line solenoid is de-energized (valve closes). CADM initiates a TRIP event (compressor demand sensed at CADM terminal Y but no current is measured at T1, T2, T3 motor sensors); CADM relay opens and RED LED is illuminated. TRIP condition maintains lockout of compressor operation until CADM is manually reset. Reset CADM by cycling unit main power.

Reversing valve solenoid remains de-energized until the next Cooling cycle is initiated.

Defrost Cycle —

During the Heating Mode, frost and ice can develop on the outdoor coil. Defrost sequence will clear the frost and ice from the coil by briefly reversing the Heating sequence periodically.

A window to test for a need to run the Defrost cycle opens at a fixed period after the end of the last Defrost cycle or the previous test window closed. The window period is determined by the configuration settings on the DFB's DIP switches (see unit wiring diagram).

If the outdoor coil's Defrost Thermostat switch (DFT) is closed (shorting DFB terminals DFT1 and DFT1), the Defrost cycle will start. Output at OF is removed; outdoor fans stop during the Defrost cycle. Output P3-7 (RVS1) is energized; reversing valve solenoid RVS is energized and reversing valve changes position, placing the circuit in a Cooling mode flow, directing hot gas into the outdoor coil where its heat melts the frost and loosens the ice on the coil face.

During the Defrost cycle, output EHEAT is also energized (if not already energized by a thermostat W2 demand); supplemental heater will be energized. During the Defrost Cycle, LED1 on the DFB will be illuminated. The Defrost cycle ends when DFT opens (as liquid temperature exiting the coil rises above DFT setpoint) or the defrost cycle runs for 10 minutes. Output at EHEAT is removed; supplemental heater will be de-energized (unless thermostat has a W2 demand). Output at OF is restored; outdoor fans start again. Output P3–7 (RVS1) is removed; reversing valve returns to Heating position.

Defrost cycle is fixed at a maximum 10 minute duration limit. The period to test and initiate a Defrost cycle can be configured for 30, 60, 90 or 120 minutes.

Supplemental Heat/Emergency Heat —

Supplemental heat type is determined by 40RUQ indoor unit options and accessories. This heat is initiated when the indoor unit W2 terminal is energized by the thermostat. (Or as detailed in “Defrost Cycle” above.) The thermostat may energize W2 as supplemental (2nd stage) heat at higher space heating demand, or when selected as emergency heat mode. When the space heating demand decreases below the 2nd stage limit, or emergency heat is turned off, W2 is de-energized, and supplemental heat is turned off.

Cooling and Heating Shutdown —

Partial or complete cooling or heating functions may shutdown caused by loss of main power, open pressure switches, diagnostic alarms, or open internal compressor protections. See Service section for further details.

ROUTINE SYSTEM MAINTENANCE

These items should be part of a routine maintenance program, to be checked every month or two, until a specific schedule for each can be identified for this installation:

Quarterly Inspection (and 30 days after initial start) —

Indoor section

- Coil cleanliness checked.
- Return air filter replacement
- Belt tension checked
- Belt condition checked
- Pulley alignment checked
- Fan shaft bearing locking collar tightness checked
- Condensate drain checked
- Blower motor amperage

Outdoor Section

- Fan motor mounting bolts tightness
- Compressor mounting bolts
- Fan blade positioning
- Control box cleanliness and wiring condition
- Wire terminal tightness
- Refrigerant charge level

Economizer or Outside Air Damper

- Inlet filters condition
- Check damper travel (economizer)
- Check gear and dampers for debris and dirt

SERVICE

Refrigeration System

▲ CAUTION

EQUIPMENT DAMAGE HAZARD

Failure to follow this caution may result in damage to equipment .

This system uses Puron[®] refrigerant which has higher pressures than R-22 and other refrigerants. No other refrigerant may be used in this system. Gage set, hoses, and recovery system must be designed to handle Puron[®]. If you are unsure consult the equipment manufacturer.

Compressor Oil —

▲ CAUTION

EQUIPMENT DAMAGE HAZARD

Failure to follow this caution may result in damage to equipment .

The compressor in a Puron system uses a polyolester (POE) oil. This oil is extremely hygroscopic, meaning it absorbs water readily. POE oils can absorb 15 times as much water as other oils designed for HCFC and CFC refrigerants. Take all necessary precautions to avoid exposure of the oil to the atmosphere.

Servicing Systems on Roofs with Synthetic Materials —

POE (polyolester) compressor lubricants are known to cause long term damage to some synthetic roofing materials. Exposure, even if immediately cleaned up, may cause embrittlement (leading to cracking) to occur in one year or more. When performing any service which may risk exposure of compressor oil to the roof, take appropriate precautions to protect roofing. Procedures which risk oil leakage include but are not limited to compressor replacement, repairing refrigerants leaks, replacing refrigerant components such as filter drier, pressure switch, metering device, coil, accumulator, or reversing valve.

Synthetic Roof Precautionary Procedure:

1. Cover extended roof working area with an impermeable polyethylene (plastic) drop cloth or tarp. Cover an approximate 10 x 10 ft (3.3 x 3.3 m) area.
2. Cover area in front of the unit service panel with a terry cloth shop towel to absorb lubricant spills and prevent run-offs, and protect drop cloth from tears caused by tools or components.

3. Place terry cloth shop towel inside unit immediately under component(s) to be serviced and prevent lubricant run-offs through the louvered openings in the base pan.
4. Perform required service.
5. Remove and dispose of any oil contaminated material per local codes.

Liquid Line Filter Drier —

The factory-provided reversible filter drier is specifically designed to operate with Puron[®]. Replace the filter drier with factory-authorized components only with a filter drier with desiccant made from 100% molecular sieve grade XH-11. Filter drier must be replaced whenever the refrigerant system is opened.

When removing a filter drier, use a tubing cutter to cut the drier from the system. **Do not unsweat a filter drier** from the system. Heat from unsweating will release moisture and contaminants from drier into system.

Field Refrigerant Access Ports —

Field service access to refrigerant pressures is through the access ports located at the service valves (see Figs 29, 31 and 33). These ports are 1/4-in SAE Flare couplings with Schrader check valves and service caps. Use these ports to admit nitrogen to the field tubing during brazing, to evacuate the tubing and evaporator coil, to admit initial refrigerant charge into the low-side of the system and when checking and adjusting the system refrigerant charge. When service activities are completed, ensure the service caps are in place and secure; check for leaks. If the Schrader check valve must be removed and re-installed, tighten to 2-3 in-lbs (23-34 N-cm).

Outdoor Coil Metering Devices —

The metering devices are multiple fixed-bore devices (Acutrol[™]) swaged into the horizontal outlet tubes from the liquid header, located at the entrance to each outdoor coil circuit path. These are non-adjustable. Service requires replacing the entire liquid header assembly.

To check the outdoor coil, disconnect the outdoor fan motor. Start the circuit in a Heating Mode (jumper R to W1) and observe the frost pattern on the face of the outdoor coil. A frost pattern should develop uniformly across the face of the outdoor coil starting at each tube at the Acutrol nipple locations.

Failure to develop frost at an outlet tube can indicate a plugged or a missing orifice.

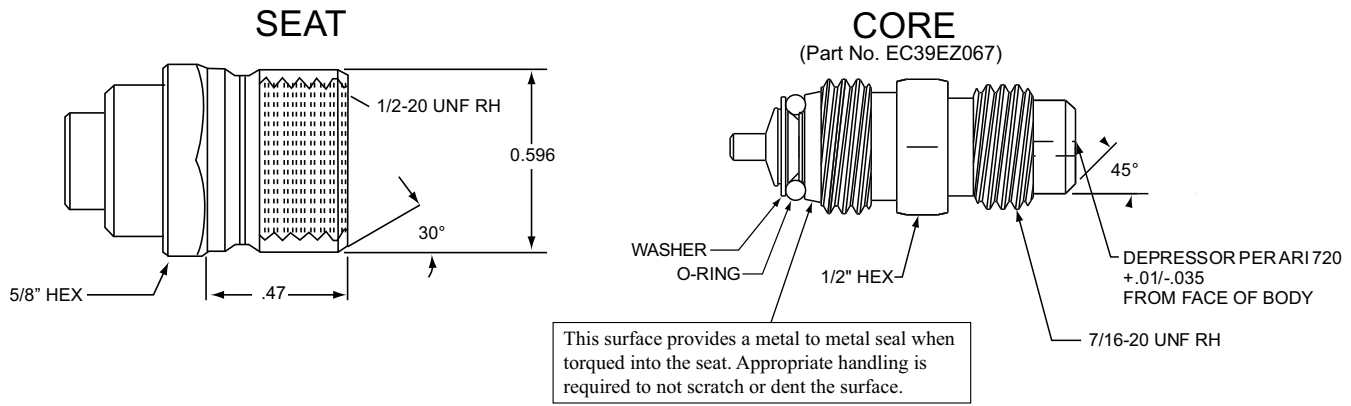

Fig. 24 - CoreMax Access Port Assembly

C08453

38AUQ

Refrigerant System Pressure Access Ports —

There are two access ports in each circuit - on the suction tube near the compressor and on the discharge tube near the compressor. These are brass fittings with black plastic caps. The hose connection fittings are standard 1/4 SAE Male Flare couplings.

The brass fittings are two-piece High Flow valves, with a receptacle base brazed to the tubing and an integral spring-closed check valve core screwed into the base. (See Fig. 24.) This check valve is permanently assembled into this core body and cannot be serviced separately; replace the entire core body if necessary. Service tools are available from RCD that allow the replacement of the check valve core without having to recover the entire system refrigerant charge. Apply compressor refrigerant oil to the check valve core's bottom o-ring. Install the fitting body with 96 +/-10 in-lbs of torque; do not overtighten.

Compressor Protection

Compressor Overcurrent —

The compressor has internal limbered motor protection.

Compressor Overtemperature Protection (IP) —

The compressor has an internal protector to protect it against excessively high discharge gas temperatures.

Crankcase Heater —

The heater prevents refrigerant migration and compressor oil dilution during shutdown whenever compressor is not operating. The heater is wired to cycle with the compressor; the heater is off when compressor is running, and on when compressor is off.

The crankcase heater will operate as long as the power circuit is energized. The main disconnect must be on to energize the crankcase heater.

IMPORTANT: Never open any switch or disconnect that energizes the crankcase heater unless unit is being serviced or is to be shut down for a prolonged period. After a prolonged shutdown on a service job, energize the crankcase heater for 24 hours before starting the compressor.

High Pressure Switch —

The system is provided with a high pressure switch mounted on the discharge line. The switch is stem-mounted and brazed into the discharge tube. Trip setting is 630 ± 10 psig (4344 ± 69 kPa) when hot. Reset is automatic at 505 ± 20 psig (3482 ± 140 kPa).

Loss of Charge Switch —

The system is protected against a loss of charge and low evaporator coil loading condition by a loss of charge switch located on the liquid line. The switch is stem-mounted. Loss of Charge Switch trip setting is 27 psig ± 3 psig (186 ± 21 kPa). Reset is automatic at 44 ± 5 psig (303 ± 35 kPa).

Outdoor Fan Motor Protection —

The outdoor fan motors are internally protected against overtemperature.

Control Circuit, 24-V —

The control circuit is protected against overcurrent conditions by circuit breakers mounted on control transformer TRAN1 and TRAN2. Reset is manual.

Commercial Defrost Control

The Commercial Defrost Control Board (DFB) coordinates thermostat demands for one stage cooling, first stage heating, emergency heating and defrost control with unit operating sequences. See Fig. 26 for board arrangement.

The DFB is located in the 38AUQ's main control box (see Fig. 25). All connections are factory-wired. Refer to Table 9 for details of DFB Inputs and Outputs.

Table 9 – 38AUQ Defrost Board I/O and Jumper Configurations

38AUQ

Inputs

Point Name	Type of I/O	Connection Pin Number	Unit Connection	Note
G Fan	DI, 24-vac	P2-3		Not used
Y1 Cool 1	DI, 24-vac	P2-5	TB-Y1	
W1 Heat 1	DI, 24-vac	P2-7	TB-W1	
Y2 Cool 2	DI, 24-vac	P2-4	TB-Y2	38AUQ(D,E) only
R Power	24-vac	P3-1	TRAN2	
C Common	24-vac, ground	P3-3	TRAN2	
DFT1 Defrost Switch	DI, 24-vac	DFT-1 to DFT-1	DFB	
DFT Jumper	DI, 24-vac	DFT-1 to DFT-2		38AUQ(D,E) only

Outputs

Point Name	Type of I/O	Connection Pin Number	Unit Connection	Note
OF OD Fan	DO, 24-vac	OF	OFR	
RVS1	DO, 24-vac	P3-7 to P3-5	RVS1	Energize in COOL
COMP 1	DO, 24-vac	P3-10	CADM1-Y	
TB-W2	DO, 24-vac	E-HEAT	HC-1 (TB4-1)	
COMP 2 / 2 nd Stage	DO, 24-vac	P3-8	CADM2-Y/CADM1-Y2	38AUQ(D,E) only

Configuration

Point Name	Type of I/O	Connection Pin Number	Unit Connection	Note
Select Jumper	24-vac	P1-1		
1 Compressor	24-vac	P1-2		
2 Compressor	24-vac	P1-3		38AUQ(D,E) only

Speed-Up Configuration

Point Name	Type of I/O	Connection Pin Number	Unit Connection	Note
Speed-Up Jumper		JMP17		
Speed-Up Jumper		JMP18		

Jumper for 1-3 secs: Factory Test, defrost runs for 12 seconds or less
 Jumper for 5-20 secs: Forced Defrost, defrost runs for 30 secs if DFT1 is open

DFB Power: 24-V at Pin P3-1, COM at P3-3 (required in all modes)

		MODE					
		COOL	OFF After COOL	HEAT-1	HEAT-2	OFF After HEAT-1	DEFROST During HEAT
Inputs	Pin						
Y1	P2-5	24-V	0-V	0-V	0-V	0-V	0-V
W1	P2-7	0-V	0-V	24-V	24-V	0-V	24-V
DFT	DFT1-DFT1	OPEN	OPEN	Note 1	Note 1	Note 1	CLOSED
Outputs	Pin						
OD Fans	OF	24-V	0-V	24-V	24-V	0-V	0-V
Rev Valve	P3-7	24-V	24-V	0-V	0-V	0-V	24-V
Compressor	P3-10	24-V	0-V	24-V	24-V	0-V	24-V
Electric Heat	E-HEAT	0-V	0-V	0-V	0-V Note 2	0-V	24-V
W2		0-V	0-V	0-V	24-V	0-V	0 or 24-V

Notes:

- DFT may be OPEN or CLOSED during Heat mode operation, depending on outdoor coil temperature. Defrost mode cannot start until Time window opens in DFB Defrost mode logic.
- Call for electric heat may originate at the space thermostat (space demand) or at the DFB during Defrost. Thermostat signal will also be present on 38AUQ's W2 terminal and the DFB's E-HEAT terminal.
- Single Circuit, two stage units are configured as two compressor unit on the defrost board.

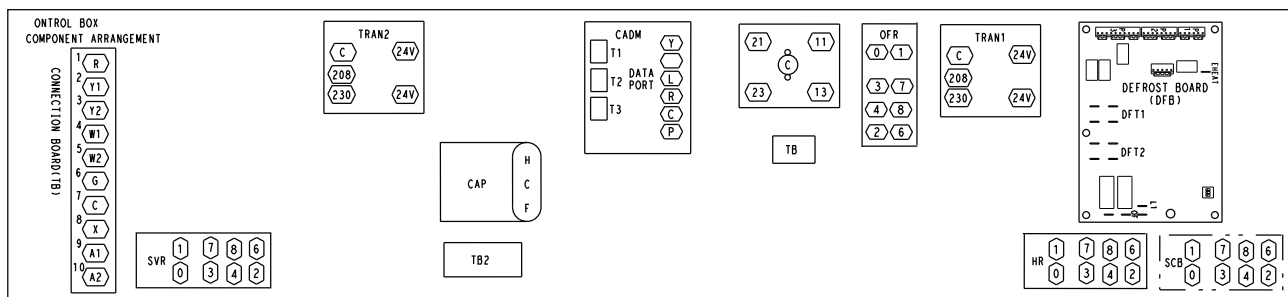

Fig. 25 - Defrost Control Board (DFB) Location

C11044

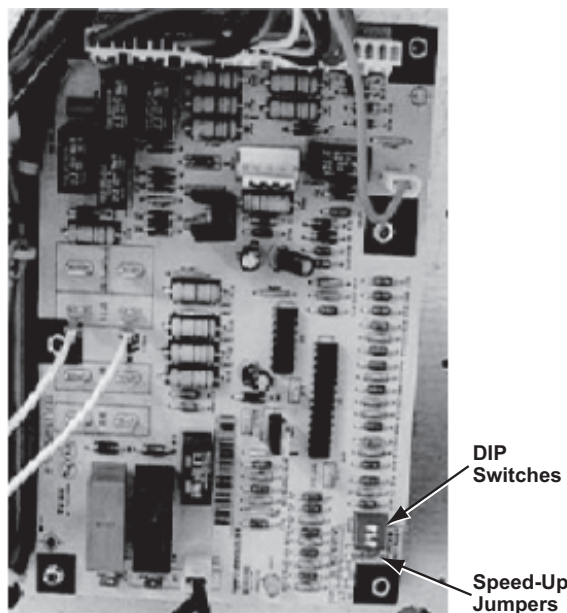

Fig. 26 - Defrost Control Board (DFB) Arrangement

C09275

Reversing Valve Control —

The DFB has an output for unit reversing valve control. Operation of the reversing valve is based on internal logic; this application does not use an “O” or “B” signal to determine reversing valve position. Reversing valve is energized during the Cooling stage and de-energized during Heating cycles. Once energized at the start of a Cooling stage, the reversing valve will remain energized until the next Heating cycle demand is received. Once de-energized at the start of a Heating cycle, the reversing valves will remain de-energized until the next Cooling stage is initiated.

Compressor Control —

The DFB receives inputs indicating Stage 1 or 2 Cooling and Stage 1 Heating from the space thermostat or unit control system (PremierLink); it generates commands to start compressor with or without reversing valve operation to produce Stage 1 or 2 Cooling, or Stage 1 Heating.

Defrost —

The defrost control mode is a time/temperature sequence. There are two time components: The continuous run period and the test/defrost cycle period. The temperature component is provided by the defrost thermostat (DFT1) mounted on the outdoor coil.

The continuous run period is a fixed time period between the end of the last defrost cycle (or start of the current Heating cycle) during which no defrost will be permitted. This period can be set at 30, 60, 90 or 120 minutes by changing the

positions of DIP switches SW1 and SW2 (see Fig. 27 and Table 10). The default run period is 60 minutes.

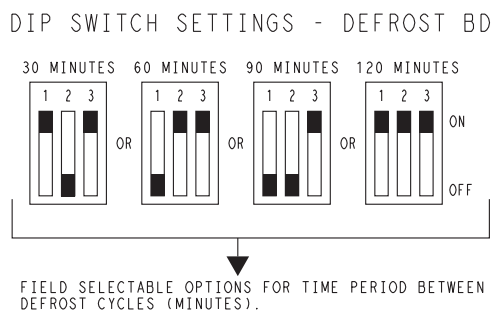

C10790

Fig. 27 - DIP Switch Settings — Defrost Board

At the end of the continuous run period, the defrost control will test for a need to defrost. DFT1 controls the start and termination of the defrost cycle. If DFT1 is still open, the defrost test/run window is closed and the control repeats the continuous run period. If DFT1 is closed, the defrost cycle is initiated. The defrost period will end when DFT1 opens (indicating the outdoor coil has been cleared of frost and ice) or a 10 minute elapsed period expires, whichever comes first.

At the end of the unit defrost cycle, the unit will be returned to Heating cycle for a full continuous run period.

If the space heating load is satisfied and compressor operation is terminated, the defrost control will remember where the run period was interrupted. On restart in Heating, the defrost control will resume unit operation at the point in the run period where it was last operating.

Defrost Thermostat —

The DFT is a temperature switch that monitors the surface temperature of the outdoor coil circuits. The switch is mounted on a vapor header tube above the vapor header’s center check valve. See Fig. 28 for specific unit size locations.

During the Heating mode, this tube location contains cold evaporating fluid entering the outdoor coil’s evaporator circuit; during Defrost/Cooling mode, this tube location contains condensed liquid or mixed-phase condensing refrigerant entering the subcooler circuit. A surface temperature below 30°F during Heating mode indicates the potential to form frost or ice on the outdoor coil; this condition will initiate a Defrost cycle at the next DFB test period. During the Defrost mode, this tube location will warm as the frost and ice on the outdoor coil are removed, until the switch opens and terminates the Defrost cycle.

The DFT switch closes on temperature drop at 30°F (-1°C) and resets open on temperature rise at 80°F (27°C).

Table 10 – Dip Switch Position

Switch No.	1		2		1		2		1		2		3	
1	■				■				■	■			■	On
0		■	■			■	■					■		Off
	30 minutes			60 minutes			90 minutes			120 minutes			Fan Delay	

Defrost Speedup Functions —

The DFB permits the servicer to speed-up the defrost cycle. There are two speed-up sequences: relative speed-up and an immediate forced defrost. Speed-up sequences are initiated by shorting jumper wires JMP17 and JMP18 together (see Fig. 26); use a straight-edge screwdriver.

Shorting the jumpers for a period of 1 to 3 secs reduces the defrost timer periods by a factor of 0.1 sec/minute. (For example, the 90 min run period is reduced to 9 secs.)

The DFB will step the unit through a Heating cycle and a Defrost cycle using these reduced time periods. This mode ends after the Defrost cycle.

Shorting the jumpers for a period of 5 to 20 secs bypasses the remaining continuous run period and places the unit in a Forced Defrost mode. If the DFT is closed when this mode is initiated, the unit will complete a normal defrost period that will terminate when the DFT opens or the 10 minute defrost cycle limit is reached. If the DFT is open when this mode is initiated, the Defrost cycle will run for 30 secs. Both modes end at the end of the Defrost cycle.

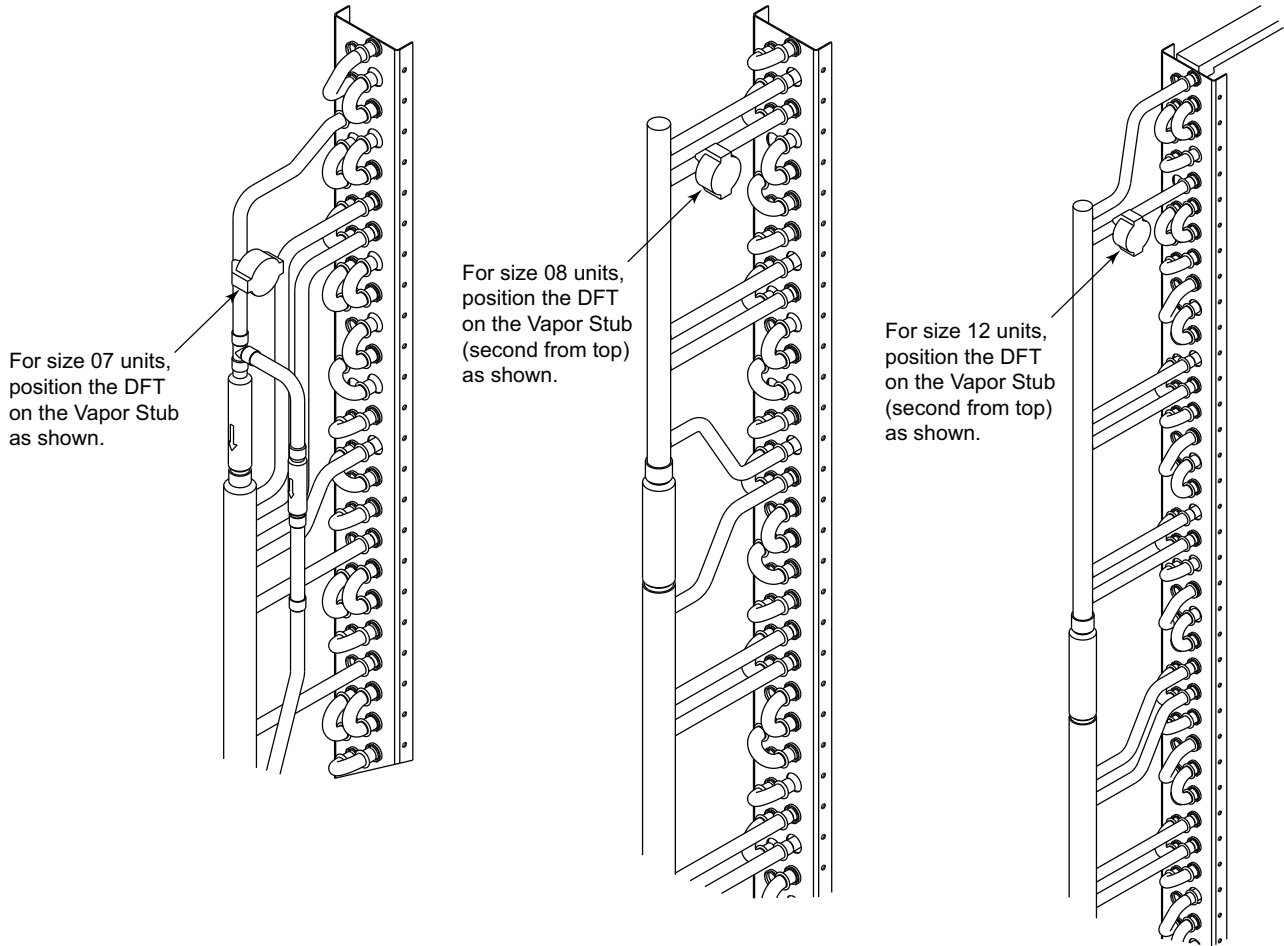

Fig. 28 - DFT Mounting Locations (Per Unit Size)

C11242

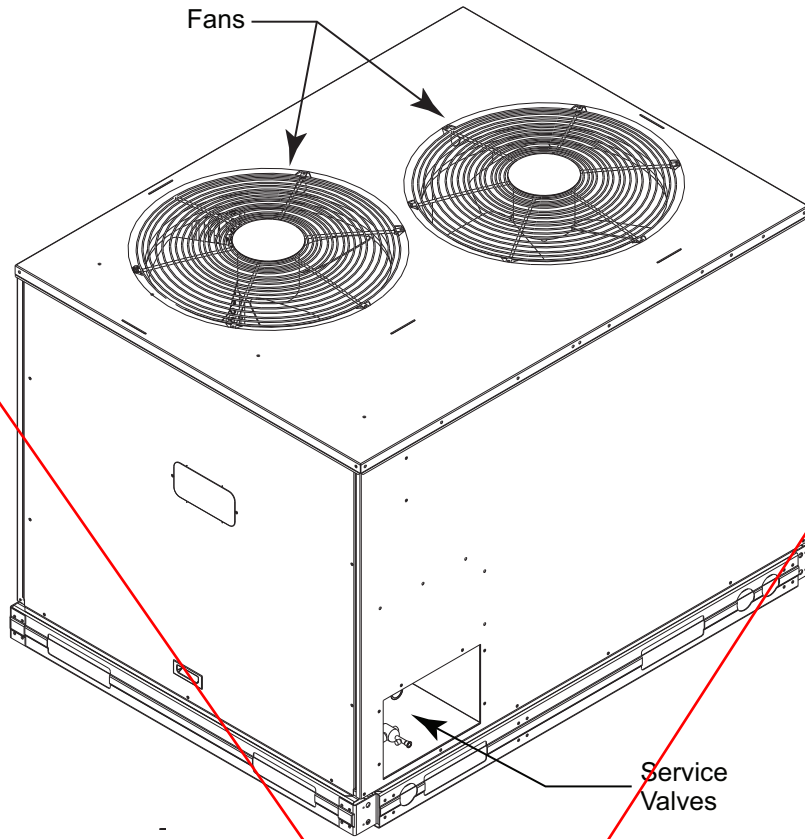

Fig. 29 - 38AUQ*07 Exterior

C11045

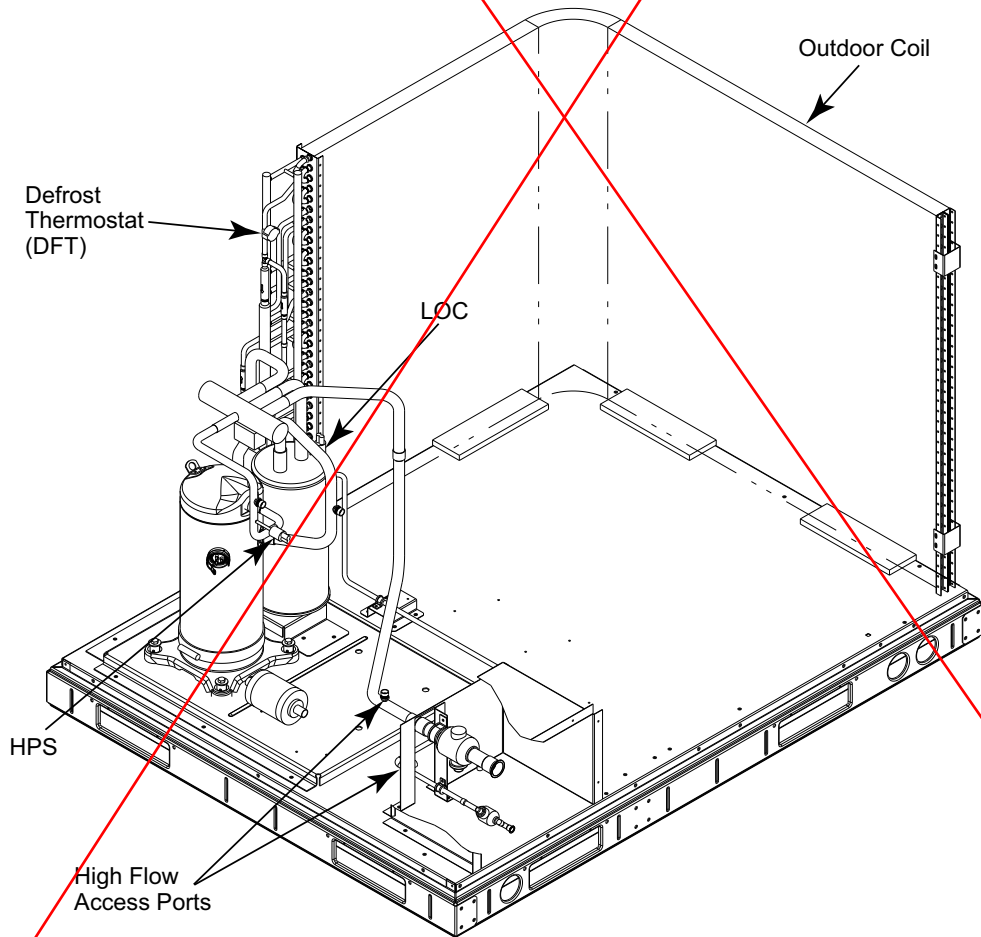

Fig. 30 - 38AUQ*07 Interior

C150032

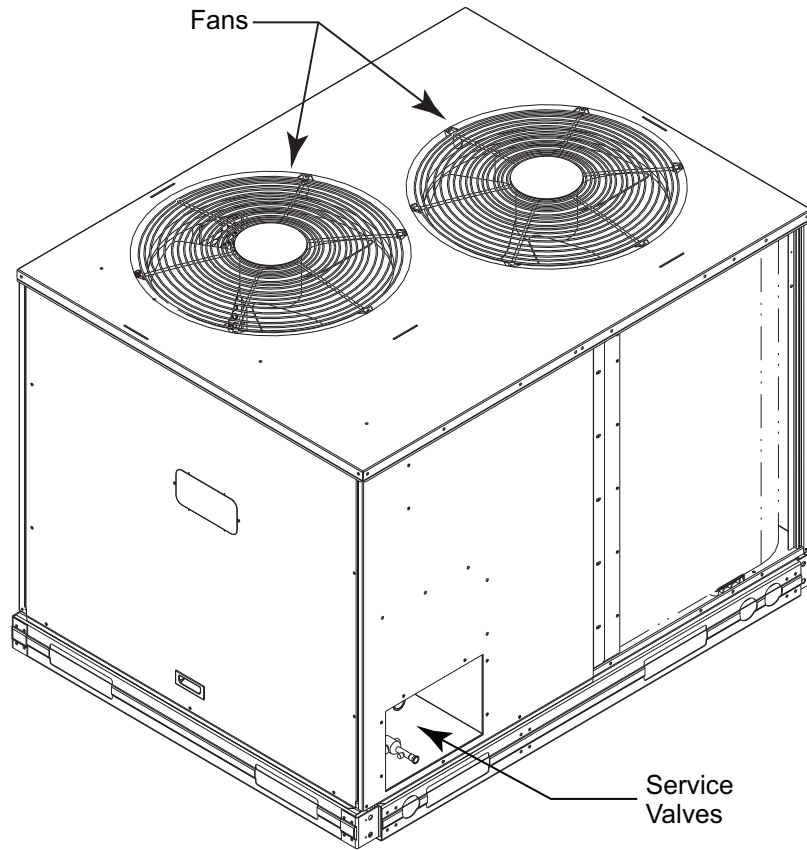

Fig. 31 - 38AUQ*08 Exterior

C11047

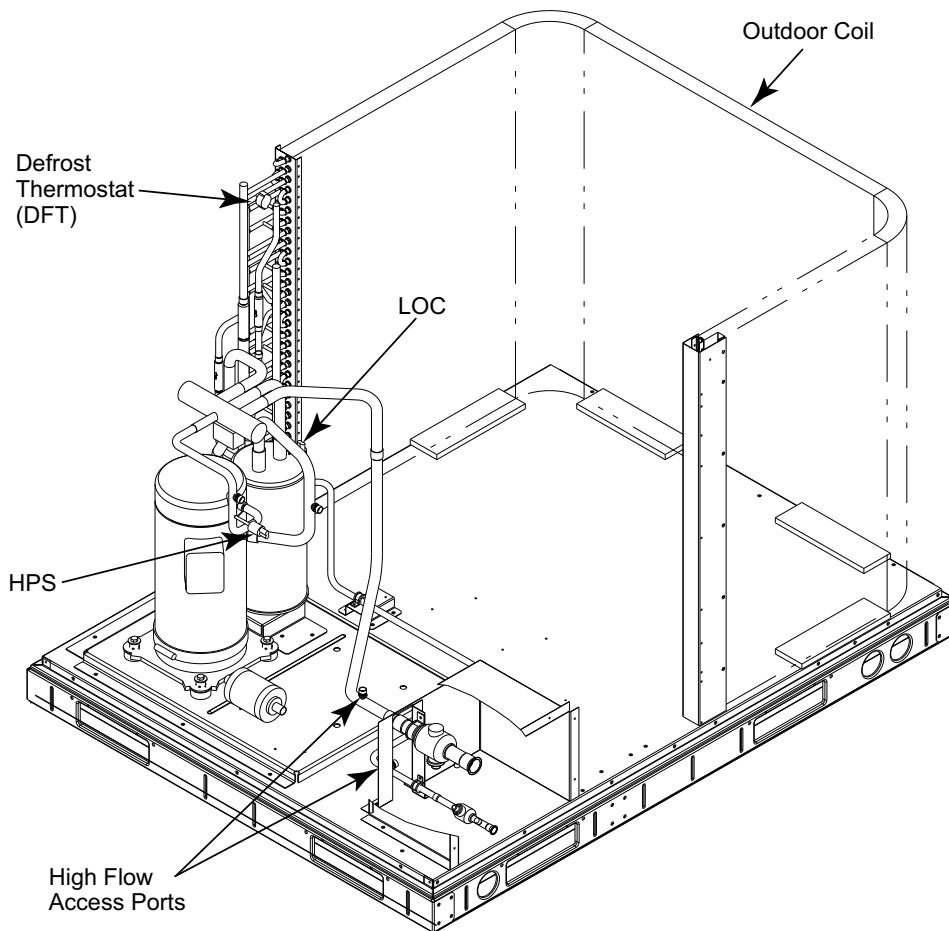

Fig. 32 - 38AUQ*08 Interior

C150033

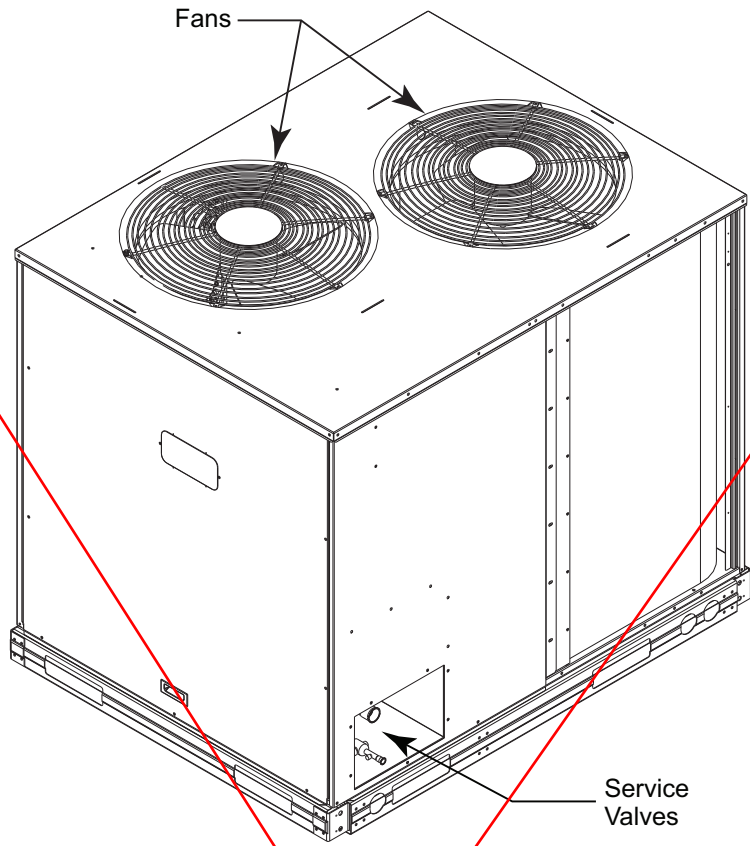

Fig. 33 - 38AUQ*12 Exterior

C11049

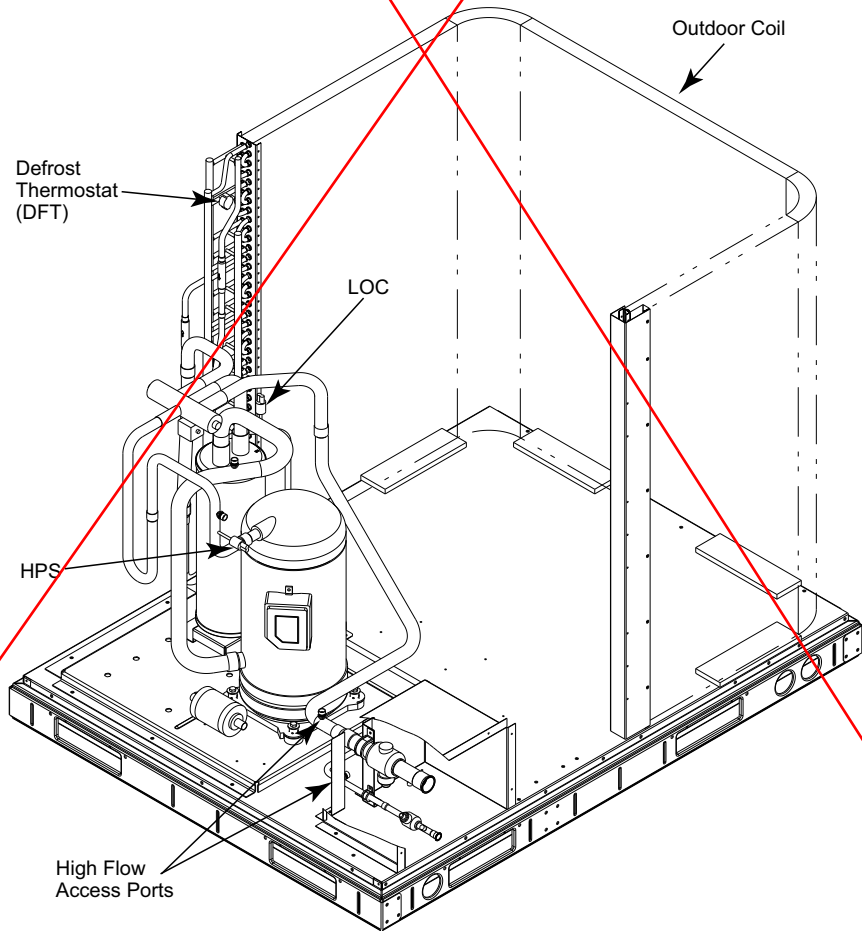

Fig. 34 - 38AUQA/B12 Interior

C150034

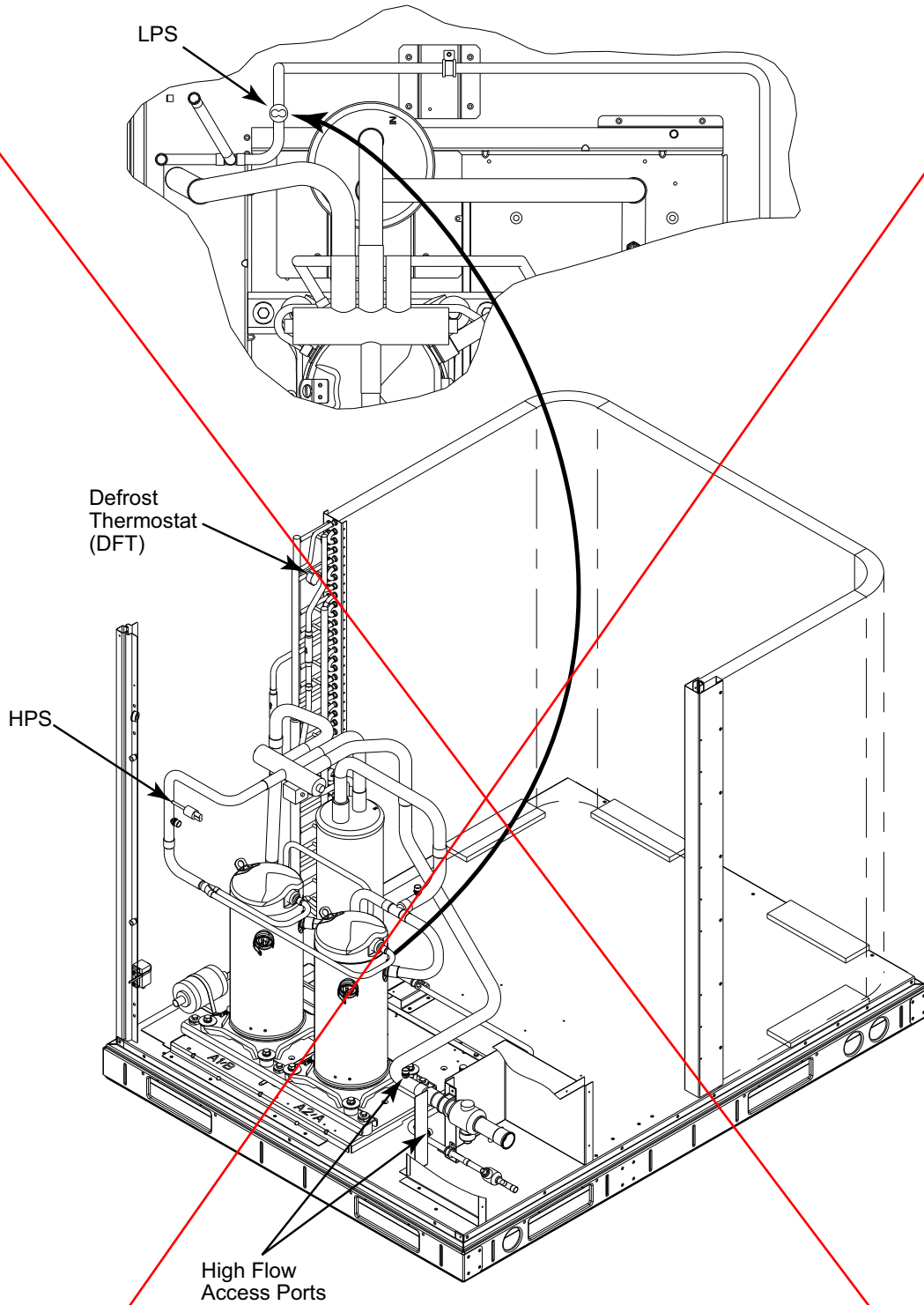

Fig. 35 - 38AUQD/E12 Interior

C150424

COMFORT ALERT DIAGNOSTIC MODULE

The Comfort Alert Diagnostic Module (CADM) monitors and analyzes data from the Copeland Scroll® three-phase compressor and the thermostat demand. The CADM also provides a 3-minute anti-recycle time delay to compressor cycling.

The CADM detects causes for electrical and system related failures. Flashing LEDs communicate the Alert codes to guide service technicians in accurately and quickly troubleshooting the system and determining root cause for the failure.

Inputs to the CADM include 24-vac power, demand signal Y, Y2, compressor contactor coil (common side) and compressor power leads (from the compressor contactor).

38AUQ

Input	Terminal	Voltage
Control Power	R	24-V
Control Common	C	24-V
Demand	Y	24-V
Demand*	Y2	24-V
Contacting Coil	P	24-V
Compressor T1	T1	Line
Compressor T2	T2	Line
Compressor T3	T3	Line

* NOTE: Applies to 38AUQ(D,E)07 only

Control of the compressor contactor coil is through a contact between terminals P and C.

Communications of status and alert conditions is through three LEDs located on the top edge of the module housing (see Fig. 36): POWER (green), ALERT (yellow), and TRIP (red).

The POWER LED indicates the presence of control power to the CADM.

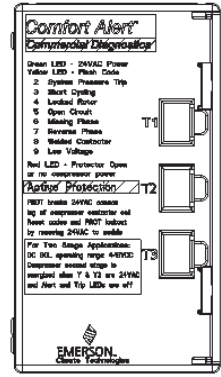
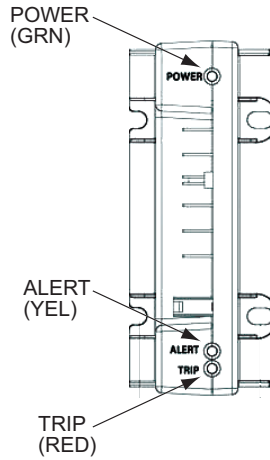

Fig. 36 - CADM Housing/LED Locations

C10086

The ALERT LED indicates an abnormal condition exists in the system through a flash code. The ALERT LED will blink a number of times consecutively, pause and the repeat the process. The number of blinks, defined in Table 10, correlates to a particular abnormal condition; troubleshooting tips are provided for each Alert code. Reset of the ALERT may be automatic or manual. If the fault condition causing the Alert is self-corrected, the Alert code will be removed and the CADM will automatically reset and allow the system to restart normally. Manual reset for lockouts requires that main power to the 38AUQ unit be recycled after the cause for the Alert condition has been detected and corrected.

The TRIP LED indicates either a time-delay period is currently active (RED LED is blinking) or the module has locked out the compressor (RED LED is on steady). A lockout condition will occur for some faults as identified in Table 11. Reset of the TRIP LED requires that unit main power be recycled after the loss of power to the compressor condition has been detected and corrected.

Simultaneous Blinking of YELLOW and RED LEDs indicates control power input to the CADM is low. Check control circuit transformer and wiring.

Troubleshooting the CADM Wiring – Flashing LEDs also indicate wiring problems to the CADM. See Table 12 for discussion of additional LED flash codes and troubleshooting instructions.

Table 11 – LED Status Codes

Status LED	Status LED Description	Status LED Troubleshooting Information
Green "POWER"	Module has power	Supply voltage is present at module terminals
Red "TRIP" LED On Solid	Thermostat demand signal Y is present, but the compressor is not running.	<ol style="list-style-type: none"> Compressor protector is open Condensing unit power disconnect is open Compressor circuit breaker or fuse(s) is open Broken supply wires or connector is not making contact Compressor power wires not routed through Comfort Alert Compressor contactor has failed open
Red "TRIP" LED Flashing	The anti-short cycle timer (3 minutes), in module is preventing compressor restart.	
Module locks out compressor when compressor damaging ALERT code appears. Lockout ALERT codes are noted in the Status LED Description. During a compressor lock out, 24VAC power must be removed from module to manually reset.		
Yellow "ALERT" LED On Solid	A short circuit or over current condition exists on PROT terminal.	<ol style="list-style-type: none"> Compressor contactor coil shorted Electrical load too high for PROT circuit (maximum 1 Amp) 24 V AC wired directly to PROT terminal
Yellow "ALERT" Flash Code 2	System Pressure Trip Discharge pressure out of limits or compressor overload (if no high pressure switch in system) LOCKOUT	<ol style="list-style-type: none"> High head pressure Condenser coil poor air circulation (dirty, blocked, damaged) Condenser fan is not running If low pressure switch is open: Refer to Code 3 for troubleshooting
Yellow "ALERT" Flash Code 3	Short Cycling Compressor is running only briefly LOCKOUT	<ol style="list-style-type: none"> If low pressure switch is open: <ol style="list-style-type: none"> Low refrigerant charge Evaporator blower is not running Evaporator coil is frozen Faulty metering device Condenser coil is dirty Liquid line restriction (filter drier blocked if present) If high pressure switch is open, go to Flash Code 2 information Intermittent thermostat demand signal System or control board defective
Yellow "ALERT" Flash Code 4	Locked Rotor LOCKOUT	<ol style="list-style-type: none"> Low line voltage to compressor Excessive liquid refrigerant in compressor Compressor bearings are seized
Yellow "ALERT" Flash Code 5	Open Circuit	<ol style="list-style-type: none"> Condensing unit power disconnect is open Compressor circuit breaker or fuses are open Compressor contactor has failed open High pressure switch is open and requires manual reset Broken supply wires or connector is not making contact Unusually long compressor protector reset time due to extreme ambient temperature Compressor windings are damaged
Yellow "ALERT" Flash Code 6	Missing Phase LOCKOUT	<ol style="list-style-type: none"> Compressor fuse is open on one phase Broken wire or connector on one phase Compressor motor winding is damaged Utility supply has dropped one phase
Yellow "ALERT" Flash Code 7	Reverse Phase LOCKOUT	<ol style="list-style-type: none"> Compressor running backward due to supply phase reversal
Yellow "ALERT" Flash Code 8	Welded Contactor Compressor always runs	<ol style="list-style-type: none"> Compressor contactor has failed closed Thermostat demand signal not connected to module
Yellow "ALERT" Flash Code 9	Low Voltage Control circuit < 18VAC	<ol style="list-style-type: none"> Control circuit transformer is overloaded Low line voltage to compressor

38AUG

Table 12 – CADM Troubleshooting

Miswired Module Indication	Recommended Troubleshooting Action
Green LED is not on, module does not power up	Determine if both R and C module terminals are connected. Verify voltage in present at module's R and C terminals. NOTE: The CADM requires a constant nominal 24VAC power supply. The wiring to the module's R and C terminals must be directly from the control transformer. The module cannot receive its power from another device that will interrupt the 24VAC power supply. See Figs. 21 – 23, the 38AUQ Wiring Diagrams.
Green LED Intermittent, module powers up only when compressor runs	Determine if R and Y terminals are wired in reverse. Verify module's R and C terminals have a constant source. See "NOTE" above for details on R and C wiring.
TRIP LED is on but system and compressor check OK	Verify Y terminal is wired properly per the 38AUQ wiring diagram (see Figs. 21 – 23). Verify voltage at contactor coil falls below 0.5VAC when off. Verify 24VAC is present across Y and C when thermostat demand signal is present. If not, R and C are reverse wired.
TRIP LED and ALERT LED flashing together	Verify R and C terminals are supplied with 19-28VAC.
ALERT Flash Code 3 (Compressor Short Cycling) displayed incorrectly	Verify Y terminal is connected to 24VAC at contactor coil. Verify voltage at contactor coil falls below 0.5VAC when off.
ALERT Flash Code 5 or 6 (Open Circuit, Missing Phase) displayed incorrectly	Check that compressor T1 and T3 wires are through module's current sensing holes. Verify Y terminal is connected to 24VAC at contactor coil. Verify voltage at contactor coil falls below 0.5VAC when off.
Alert Flash Code * (Welded Contactor) displayed incorrectly	Determine if module's Y terminal is connected. Verify Y terminal is connected to 24VAC at contactor coil. Verify 24VAC is present across Y and C when thermostat demand signal is present. If not, R and C are reverse wired. Verify voltage at contactor coil falls below 0.5VAC when off.

38AUQ

Outdoor Fans

Each fan is supported by a formed-wire mount bolted to the fan deck and covered with a wire guard. Fan motors have permanently lubricated bearings.

1. Shut off unit power supply. Install lockout tag.
2. Remove outdoor fan assembly (grille, motor, and fan).
3. Loosen fan hub setscrews.
4. Adjust fan height as shown in Fig. 37.
5. Tighten setscrews to 84 in-lbs (949 N-cm).
6. Replace outdoor fan assembly.

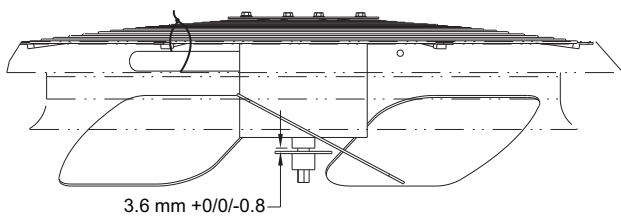

C10103

Fig. 37 - Outdoor Fan Blade Position

Lubrication

Fan Motors —

The fan motors have sealed bearings. No provisions are made for lubrication.

Compressor —

The compressor has its own oil supply. Loss of oil due to a leak in the system should be the only reason for adding oil after the system has been in operation.

Outdoor Coil Maintenance and Cleaning Recommendation

Routine cleaning of coil surfaces is essential to maintain proper operation of the unit. Elimination of contamination and removal of harmful residues will greatly increase the life of the coil and extend the life of the unit. The following maintenance and cleaning procedures are recommended as part of the routine maintenance activities to extend the life of the coil.

Remove Surface Loaded Fibers —

Surface loaded fibers or dirt should be removed with a vacuum cleaner. If a vacuum cleaner is not available, a soft non-metallic bristle brush may be used. In either case, the tool should be applied in the direction of the fins. Coil surfaces can be easily damaged (fin edges can be easily bent over and damage the coating of a protected coil) if the tool is applied across the fins.

NOTE: Use of a water stream, such as a garden hose, against a surface loaded coil will drive the fibers and dirt into the coil. This will make cleaning efforts more difficult. Surface loaded fibers must be completely removed prior to using low velocity clean water rinse.

Periodic Clean Water Rinse —

A periodic clean water rinse is very beneficial for coils that are applied in coastal or industrial environments. However, it is very important that the water rinse is made with very low velocity water stream to avoid damaging the fin edges. Monthly cleaning as described below is recommended.

⚠ CAUTION

PERSONAL INJURY AND UNIT DAMAGE HAZARD

Failure to follow this caution may result in personal injury or equipment damage.

Only approved cleaning is recommended.

Routine Cleaning of Indoor Coil Surfaces —

Periodic cleaning with Totaline® environmentally sound coil cleaner is essential to extend the life of coils. This cleaner is available from Carrier Replacement Components Division as part number P902-0301 for one gallon container, and part number P902-0305 for a 5 gallon container. It is recommended that all coils, including standard aluminum, pre-coated, copper/copper or E-coated coils be cleaned with the Totaline environmentally sound coil cleaner as described below. Coil cleaning should be part of the unit's regularly scheduled maintenance procedures to ensure long life of the coil. Failure to clean the coils may result in reduced durability in the environment.

Avoid the use of:

- coil brighteners
- acid cleaning prior to painting
- high pressure washers
- poor quality water for cleaning

Totaline environmentally sound coil cleaner is nonflammable, hypoallergenic, non bacterial, and a USDA accepted biodegradable agent that will not harm the coil or surrounding components such as electrical wiring, painted metal surfaces, or insulation. Use of non-recommended coil cleaners is strongly discouraged since coil and unit durability could be affected.

Totaline Environmentally Sound Coil Cleaner Application Equipment:

- 2¹/₂ gallon garden sprayer
- Water rinse with low velocity spray nozzle

⚠ CAUTION

UNIT DAMAGE HAZARD

Failure to follow this caution may result in corrosion and damage to the unit .

Harsh chemicals, household bleach or acid or basic cleaners should not be used to clean outdoor or indoor coils of any kind. These cleaners can be very difficult to rinse out of the coil and can accelerate corrosion at the fin/tube interface where dissimilar materials are in contact. If there is dirt below the surface of the coil, use the Totaline environmentally sound coil cleaner as described above.

⚠ CAUTION

UNIT RELIABILITY HAZARD

Failure to follow this caution may result in reduced unit performance .

High velocity water from a pressure washer, garden hose, or compressed air should never be used to clean a coil. The force of the water or air jet will bend the fin edges and increase airside pressure drop.

Totaline Environmentally Sound Coil Cleaner Application Instructions:

NOTE: Proper eye protection such as safety glasses is recommended during mixing and application.

1. Turn off unit power.
2. Remove screws holding rear corner post and top cover in place. Pivot top cover up 12 to 18 inches (305 to 457 mm) and support with a rigid support. See Fig. 38.

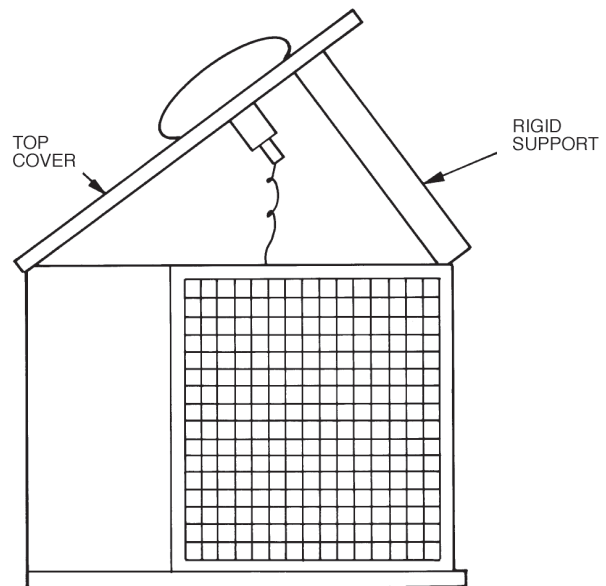

C10216

Fig. 38 - Pivot and Support Top Cover

3. Remove all surface loaded fibers and dirt with a vacuum cleaner. If a vacuum cleaner is not available, a soft non-metallic bristle brush may be used. In either case, the tool should be applied in the direction of the fins. Coil surfaces can be easily damaged (fin edges can be easily bent over and damage to the coating of a protected coil) if the tool is applied across the fins.

NOTE: Use of a water stream, such as a garden hose, against surface loaded coil will drive the fibers and dirt into the coil, making cleaning efforts more difficult. Surface loaded fibers must be completely removed prior to using low velocity clean water rinse.

4. Using a low velocity garden hose thoroughly wet finned surfaces with clean water. Be careful not to bend the fins.

5. Mix Totaline environmentally sound coil cleaner in a 2¹/₂ gallon garden sprayer according to the instructions included with the cleaner. The optimum solution temperature is 100°F (38°C).

NOTE: Do NOT USE water in excess of 130°F (54°C), as the enzymatic activity will be destroyed.

6. Thoroughly apply Totaline® environmentally sound coil cleaner solution to all coil surfaces including the finned area, tube sheets and coil headers.
7. Hold garden sprayer nozzle close to finned areas and apply cleaner with a vertical, up-and-down motion. Avoid spraying in horizontal pattern to minimize potential for fin damage.
8. Ensure cleaner thoroughly penetrates deep into finned areas.
9. Interior and exterior finned areas must be thoroughly cleaned.
10. Finned surfaces should remain wet with cleaning solution for 10 minutes.
11. Ensure surfaces are not allowed to dry before rinsing. Reapply cleaner as needed to ensure 10-minute saturation is achieved.
12. Thoroughly rinse all surfaces with low velocity clean water using downward rinsing motion of water spray nozzle. Protect fins from damage from the spray nozzle.
13. Replace top cover and rear corner posts.

Service Parts

Listings of service parts for all units are available from the Replacement Components Division's Electronic Parts Information Catalog (EPIC). EPIC is available at Totaline stores, distributor and service office parts departments and on-line at HVACPartners.com.

When entering EPIC, the full unit model number is required. The model number includes the Design Revision reference value (see Fig. 2, Position 13). The unit model number is available from the unit's information data plate. (Do not use the "catalog number" when using EPIC. The "catalog number" suppresses the Design Revision value; failure to include Design Revision value may cause an incorrect unit parts list to be displayed.) When using EPIC, enter first four digits of the model number only. Find appropriate model from sales packages listed. Be sure to choose correct voltage and Design Revision.

EPIC is a product of RCD. To comment to the EPIC program, use the "Comment" button inside the EPIC program.

FASTENER TORQUE VALUES

Table 13 – Torque Values

Compressor mounting bolts	65–75 in-lbs (734–847 N-cm)
Condenser fan motor mounting bolts	20 ±2 in-lbs (226 ±23 N-cm)
Condenser fan hub setscrew	84 ±2 in-lbs (949 ±136 N-cm)
High-flow service port	96 ±10 in-lbs (1085 ±23 N-cm)
Schrader-type service check valve	2–3 in-lbs (23–34 N-cm)
Compressor oil sightglass thread	330 ±31 in-lbs (23–34 N-cm)
Compressor to Compressor rail torque	120–168 in-lbs (1356–1898 N-cm)
Compressor rail to base pan torque	70 ±5 in-lbs (791 ±57 N-cm)

TROUBLESHOOTING

PROBLEM	CAUSE	REMEDY
Compressor and Outdoor Fan Will Not Start.	Power failure.	Call power company.
	Fuse blown or circuit breaker tripped.	Replace fuse or reset circuit breaker. Determine root cause.
	Defective thermostat, contactor, transformer, control relay, or capacitor.	Replace component.
	Insufficient line voltage.	Determine cause and correct.
	Incorrect or faulty wiring.	Check wiring diagram and rewire correctly.
	Thermostat setting too high.	Lower thermostat setting below room temperature.
	High pressure switch tripped.	See problem "Excessive head pressure."
	Low pressure switch tripped.	Check system for leaks. Repair as necessary.
Compressor Will Not Start But Outdoor Fan Runs.	Freeze-up protection thermostat tripped.	See problem "Suction pressure too low."
	Faulty wiring or loose connections in compressor circuit.	Check wiring and repair or replace.
	Compressor motor burned out, seized, or internal overload open.	Determine cause. Replace compressor or allow enough time for internal overload to cool and reset.
	Defective run/start capacitor, overload, start relay.	Determine cause and replace compressor.
Compressor Cycles (Other Than Normally Satisfying Thermostat).	One leg of 3-phase power dead.	Replace fuse or reset circuit breaker. Determine cause.
	Refrigerant overcharge or undercharge.	Recover refrigerant, evacuate system, and recharge to nameplate.
	Defective compressor.	Replace and determine cause.
	Insufficient line voltage.	Determine cause and correct.
	Blocked outdoor coil or dirty air filter.	Determine cause and correct.
	Defective run/start capacitor, overload, or start relay.	Determine cause and replace.
	Defective thermostat.	Replace thermostat.
	Faulty outdoor-fan (cooling) or indoor-fan (heating) motor or capacitor.	Replace.
Compressor Operates Continuously.	Restriction in refrigerant system.	Locate restriction and remove.
	Dirty air filter.	Replace filter.
	Unit undersized for load.	Decrease load or increase unit size.
	Thermostat set too low (cooling).	Reset thermostat.
	Low refrigerant charge.	Locate leak; repair and recharge.
	Air in system.	Recover refrigerant, evacuate system, and recharge.
Compressor Makes Excessive Noise.	Outdoor coil dirty or restricted.	Clean coil or remove restriction.
	Compressor rotating in the wrong direction.	Reverse the 3-phase power leads as described in Start-Up.
Excessive Head Pressure.	Dirty outside air or return air filter (heating).	Replace filter.
	Dirty outdoor coil (cooling).	Clean coil.
	Refrigerant overcharged.	Recover excess refrigerant.
	Air in system.	Recover refrigerant, evacuate system, and recharge.
	Condensing air restricted or air short-cycling.	Determine cause and correct.
Head Pressure Too Low.	Low refrigerant charge.	Check for leaks; repair and recharge.
	Compressor scroll plates defective.	Replace compressor.
	Restriction in liquid tube.	Remove restriction.
Excessive Suction Pressure.	High heat load.	Check for source and eliminate.
	Compressor scroll plates defective.	Replace compressor.
	Refrigerant overcharged.	Recover excess refrigerant.
Suction Pressure Too Low.	Refrigerant overcharged.	Recover excess refrigerant.
	Dirty air filter (cooling).	Replace filter.
	Dirty or heavily iced outdoor coil (heating).	Clean outdoor coil. Check defrost cycle operation.
	Low refrigerant charge.	Check for leaks; repair and recharge.
	Metering device or low side restricted.	Remove source of restriction.
	Insufficient indoor airflow (cooling mode).	Increase air quantity. Check filter and replace if necessary.
	Temperature too low in conditioned area.	Reset thermostat.
	Field-installed filter drier restricted.	Replace.
	Outdoor ambient below 25°F (cooling).	Install low-ambient kit.
Outdoor fan motor(s) not operating (heating).	Check fan motor operation.	

38AUG

APPENDIX A

AIR CONDITIONER AND HEAT PUMP WITH PURON® — QUICK REFERENCE GUIDE

- Puron® (R-410A) refrigerant operates at 50 percent to 70 percent higher pressures than R-22. Be sure that servicing equipment and replacement components are designed to operate with Puron®.
- Puron® refrigerant cylinders are rose colored.
- Recovery cylinder service pressure rating must be 400 psig, DOT 4BA400 or DOT BW400.
- Puron® systems should be charged with liquid refrigerant. Use a commercial type metering device in the manifold hose when charging into suction line with compressor operating.
- Manifold sets should be 700 psig high side and 180 psig low side with 550 psig low-side retard.
- Use hoses with 700 psig service pressure rating.
- Leak detectors should be designed to detect HFC refrigerant.
- Puron®, as with other HFCs, is only compatible with POE oils.
- Vacuum pumps will not remove moisture from oil.
- Use only factory specified liquid-line filter driers with rated working pressures greater than 600 psig.
- Do not install a suction-line filter drier in liquid-line.
- POE oils absorb moisture rapidly. Do not expose oil to atmosphere.
- POE oils may cause damage to certain plastics and roofing materials.
- Wrap all filter driers and service valves with wet cloth when brazing.
- A factory approved, liquid-line filter drier is required on every unit.
- Do not use an R-22 TXV.
- If indoor unit is equipped with a TXV, it must be changed to a Puron® TXV.
- Never open system to atmosphere while it is under a vacuum.
- When system must be opened for service, recover refrigerant, break vacuum with dry nitrogen before opening system.
- Always replace filter drier after opening system for service.
- Do not vent Puron® into the atmosphere.
- Do not use capillary tube coils.
- Observe all **warnings, cautions, and bold** text.
- All Puron® heat pumps must have indoor TXV.
- Do not leave Puron® suction line driers in place for more than 72 hours.

38AUG

APPENDIX B

WIRING DIAGRAM LIST

Unit	Cooling Stages	Electrical Characteristics	Diagram Number
38AUQA/B07	1	208/230-3-60	38AU500363
		460-3-60	38AU500362
		575-3-60	38AU500435
38AUQD/E07	2	208/230-3-60	38AU000443
		460-3-60	38AU000443
		575-3-60	38AU000444
38AUQA/B08	1	208/230-3-60	38AU500363
		460-3-60	38AU500362
		575-3-60	38AU500435
38AUQA/B12	1	208/230-3-60	38AU500363
		460-3-60	38AU500362
		575-3-60	38AU500435
38AUQD/E12	2	208/230-3-60	38AU000445
		460-3-60	38AU000445
		575-3-60	38AU000446

APPENDIX C

Low Ambient Option — Factory Installed

Units with the factory installed low ambient option are equipped with a Motormaster[®] solid-state head pressure control which regulates fan speed. A temperature sensor, mounted on circuit 1 of the outdoor coil (see Fig. 39) controls the speed of approved outdoor fan motors in order to maintain a constant head pressure in the outdoor coil. The control maintains the appropriate head pressure at low ambient temperatures down to -20°F (-28°C).

Wind baffles are required to prevent wind cross currents from causing abnormally low condensing temperatures.

Use 20-gauge sheet metal to fabricate wind baffles (see Fig. 40 and Table 14).

Operation —

Fan on/off control in heat pump units (38AUQ) is provided by an outdoor fan relay (OFR). In heat pumps, the OFR is controlled by defrost control board (DFB).

Fan motor speed in cooling mode is regulated by the temperature sensor for a minimum coil condensing temperature of approximately 100° at higher outdoor ambient temperature and 80°F at lower ambient.

For heat pump units, the speed control bypass relay (SCB) is used to bypass the speed control during the heating mode, resulting in full fan speed at all times.

To override the speed control for full fan speed operation during service or maintenance, either:

- a) remove sensor and place in hot water >120°F (>49°C)
- or
- b) rewire to bypass control by connecting speed control input and output power wires.

Troubleshooting —

OBSERVATION	POSSIBLE REMEDY
Fans won't start	Check power & wiring Check sensor location Check sensor resistance Check OFR
Cooling – Slow fan speed at start or during low outdoor ambient	Normal operation
Cooling – Slow fan speed above 85°F outdoor ambient (should be full speed)	Check sensor location Check sensor resistance Check fan motor capacitor
Cooling – motor current into speed control is greater than motor nameplate FLA	Normal operation Up to 30% higher amps at partial speed at low ambient
Heating – Full fan speed	Normal operation
Heating – Slow fan speed (should be full speed)	Check wiring Check SCB relay for speed control bypass

Speed Control Sensor Resistance —

TEMPERATURE		RESISTANCE
°F +/-2°F°	°C +/-1C	Ohms, nominal
-22	-30	88350
-4	-20	48485
14	-10	27650
32	0	16325
50	10	9950
68	20	6245
77	25	5000
86	30	4028
104	40	2663
122	50	1801
140	60	1244
158	70	876

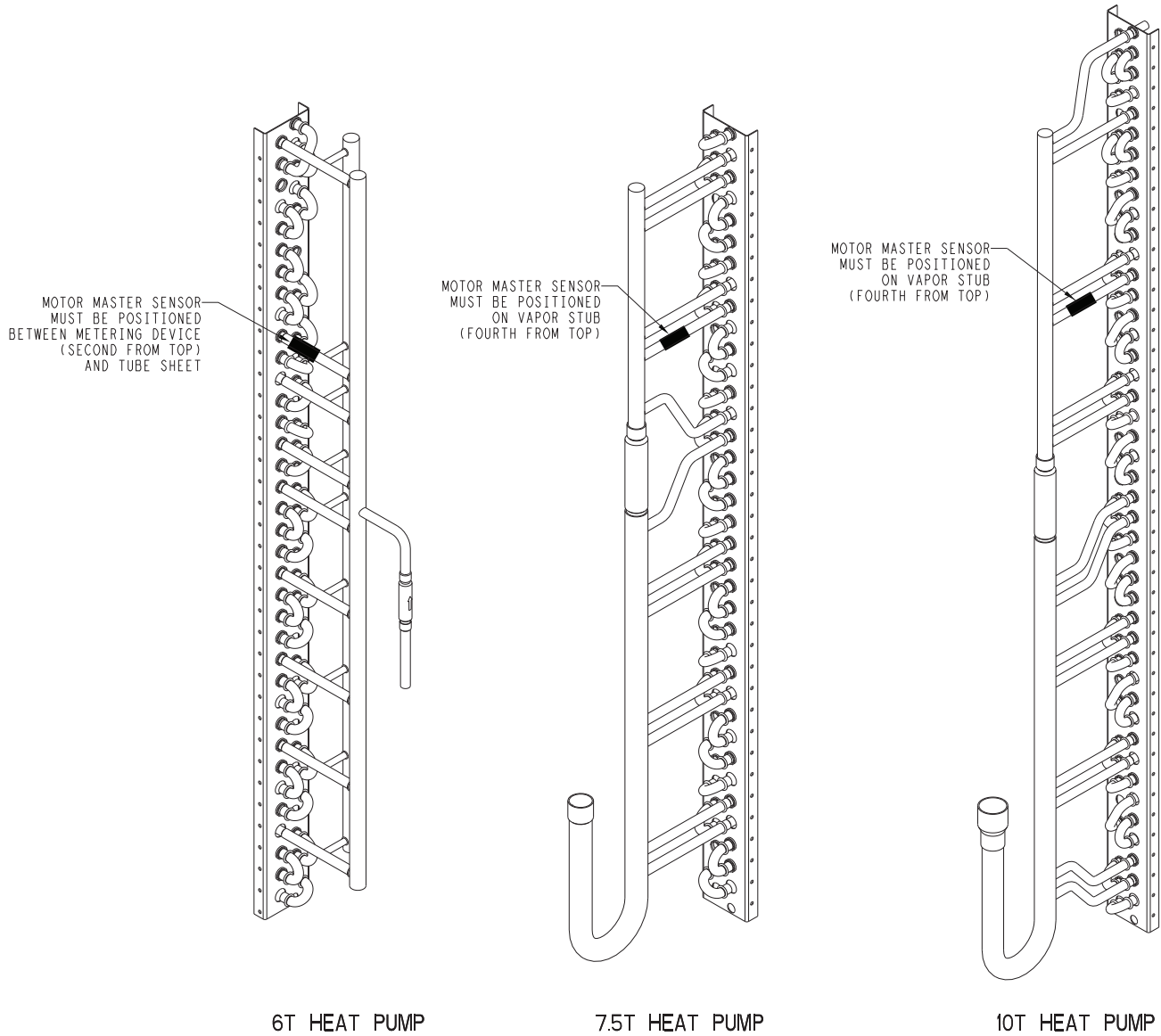

6T HEAT PUMP

7.5T HEAT PUMP

10T HEAT PUMP

C10801

Fig. 39 - Sensor Locations

Table 14 - Wind Baffle Dimensions

DIMENSIONS - INCHES											
UNIT	BAFFLE	A	B	C	D	E	F	G	H	J	K
38AUQ* 07	LEFT SIDE	28 1/2	29	29 3/4	35 1/4	1 1/4	9 1/4	17 1/4	25 1/4	33 1/4	-
	BACK	40	40 3/4	41 1/2	35 1/4	4 1/4	11 1/4	18 1/4	25 1/4	32 1/4	-
38AUQ* 08	LEFT SIDE	28 1/2	29	29 3/4	35 1/4	1 1/4	9 1/4	17 1/4	25 1/4	33 1/4	-
	BACK	40	40 3/4	41 1/2	35 1/4	4 1/4	11 1/4	18 1/4	25 1/4	32 1/4	-
	RIGHT SIDE	25	25 1/2	26 1/4	35 1/4	4 1/4	11 1/4	18 1/4	25 1/4	32 1/4	-
38AUQ *12	LEFT SIDE	28 1/2	29	29 3/4	43 1/8	1 1/4	9 1/4	17 1/4	25 1/4	33 1/4	41 1/4
	BACK	40	40 3/4	41 1/2	43 1/8	4 1/4	11 1/4	18 1/4	25 1/4	32 1/4	39 1/4
	RIGHT SIDE	25	25 1/2	26 1/4	43 1/8	4 1/4	11 1/4	18 1/4	25 1/4	32 1/4	39 1/4

DIMENSIONS - MM											
UNIT	BAFFLE	A	B	C	D	E	F	G	H	J	K
38AUQ* 07	LEFT SIDE	718	737	756	895	33	236	439	643	846	-
	BACK	1016	1035	1054	895	107	284	462	640	818	-
38AUQ* 08	LEFT SIDE	718	737	756	895	33	236	439	643	846	-
	BACK	1016	1035	1054	895	107	284	462	640	818	-
	RIGHT SIDE	629	648	667	895	107	284	462	640	818	-
38AUQ *12	LEFT SIDE	718	737	756	1095	33	236	439	643	846	1049
	BACK	1016	1035	1054	1095	107	284	462	640	818	996
	RIGHT SIDE	629	648	667	1095	107	284	462	640	818	996

0.85 (TYP)
0.47 (TYP)

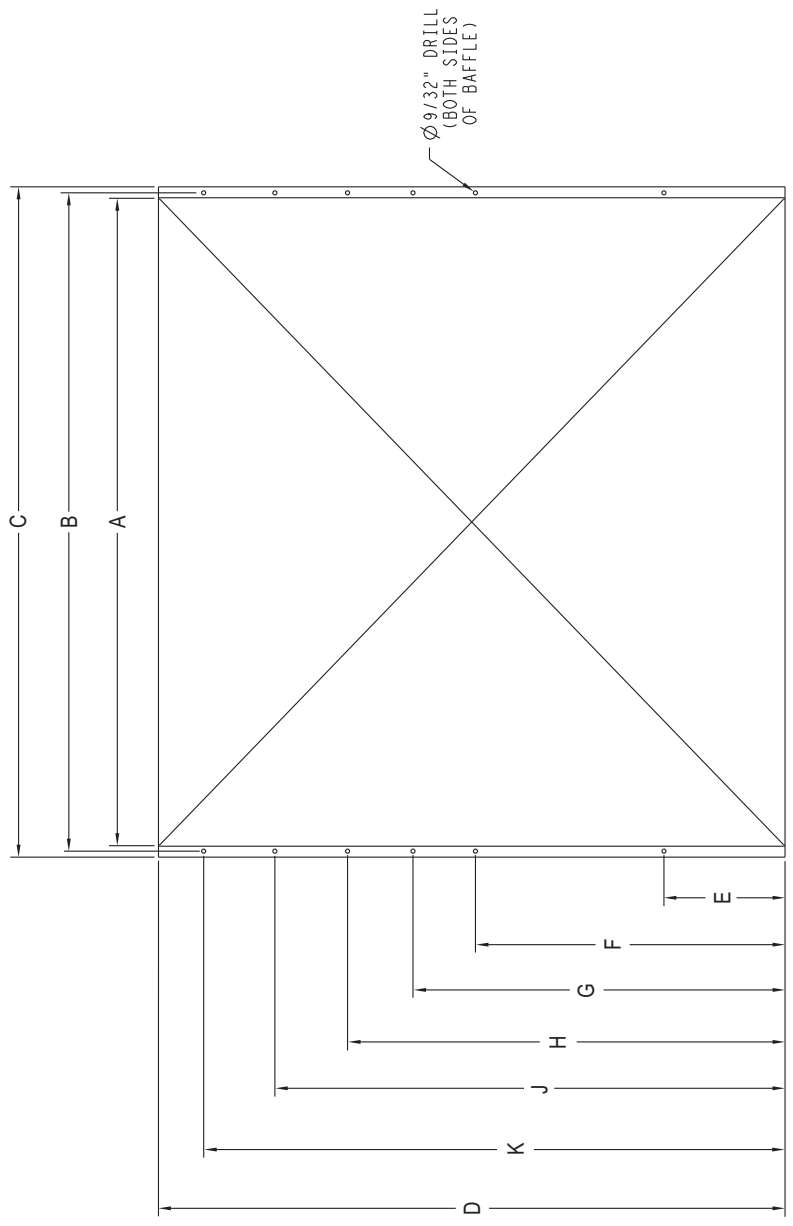
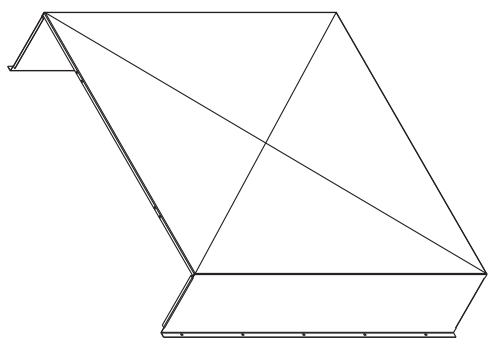
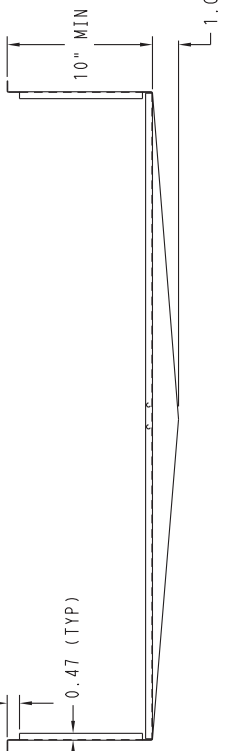

Fig. 40 - Wind Baffles

C10800

START UP CHECKLIST

I. PRELIMINARY INFORMATION

OUTDOOR: MODEL NO. _____ SERIAL NO. _____

INDOOR: MODEL NO. _____ SERIAL NO. _____

ADDITIONAL ACCESSORIES _____

II. PRE-START-UP

OUTDOOR UNIT

IS THERE ANY SHIPPING DAMAGE? (Y/N) _____

IF SO, WHERE: _____

WILL THIS DAMAGE PREVENT UNIT START-UP? (Y/N) _____

CHECK POWER SUPPLY. DOES IT AGREE WITH UNIT? (Y/N) _____

HAS THE GROUND WIRE BEEN CONNECTED? (Y/N) _____

HAS THE CIRCUIT PROTECTION BEEN SIZED AND INSTALLED PROPERLY? (Y/N) _____

ARE THE POWER WIRES TO THE UNIT SIZED AND INSTALLED PROPERLY? (Y/N) _____

CONTROLS

ARE THERMOSTAT AND INDOOR FAN CONTROL WIRING CONNECTIONS MADE AND CHECKED?
(Y/N) _____

ARE ALL WIRING TERMINALS (including main power supply) TIGHT? (Y/N) _____

HAS CRANKCASE HEATER BEEN ENERGIZED FOR 24 HOURS? (Y/N) _____

INDOOR UNIT

HAS WATER BEEN PLACED IN DRAIN PAN TO CONFIRM PROPER DRAINAGE? (Y/N) _____

ARE PROPER AIR FILTERS IN PLACE? (Y/N) _____

HAVE FAN AND MOTOR PULLEYS BEEN CHECKED FOR PROPER ALIGNMENT? (Y/N) _____

DO THE FAN BELTS HAVE PROPER TENSION? (Y/N) _____

HAS CORRECT FAN ROTATION BEEN CONFIRMED? (Y/N) _____

PIPING

IS LIQUID LINE SOLENOID VALVE LOCATED AT THE OUTDOOR COILS AS REQUIRED? (Y/N) _____

HAVE LEAK CHECKS BEEN MADE AT COMPRESSOR, OUTDOOR AND INDOOR COILS,
TXVs (Thermostatic Expansion Valves), SOLENOID VALVES, FILTER DRIERS, AND FUSIBLE PLUGS
WITH A LEAK DETECTOR? (Y/N) _____

LOCATE, REPAIR, AND REPORT ANY LEAKS. _____

HAS LIQUID LINE SERVICE VALVE BEEN OPENED? (Y/N) _____

HAS VAPOR LINE SERVICE VALVE BEEN OPENED? (Y/N) _____

38AUG

CHECK VOLTAGE IMBALANCE

LINE-TO-LINE VOLTS: AB _____ V AC _____ V BC _____ V

$(AB + AC + BC)/3 = \text{AVERAGE VOLTAGE} = \underline{\hspace{2cm}}$ V

MAXIMUM DEVIATION FROM AVERAGE VOLTAGE = _____ V

VOLTAGE IMBALANCE = $100 \times (\text{MAX DEVIATION})/(\text{AVERAGE VOLTAGE}) = \underline{\hspace{2cm}}$

IF OVER 2% VOLTAGE IMBALANCE, DO NOT ATTEMPT TO START SYSTEM!
CALL LOCAL POWER COMPANY FOR ASSISTANCE.

CHECK INDOOR UNIT FAN SPEED AND RECORD. _____

CHECK OUTDOOR UNIT FAN SPEED AND RECORD. _____

AFTER AT LEAST 10 MINUTES RUNNING TIME, RECORD THE FOLLOWING MEASUREMENTS:

	COOLING	HEATING
VAPOR PRESSURE	_____	_____
SUCTION LINE TEMP	_____	_____ (AT COMPRESSOR)
LIQUID PRESSURE	_____	_____
LIQUID LINE TEMP	_____	_____
ENTERING OUTDOOR UNIT AIR TEMP	_____	_____
LEAVING OUTDOOR UNIT AIR TEMP	_____	_____
INDOOR UNIT ENTERING-AIR DB (dry bulb) TEMP	_____	_____
INDOOR UNIT ENTERING-AIR WB (wet bulb) TEMP	_____	_____
INDOOR UNIT LEAVING-AIR DB TEMP	_____	_____
INDOOR UNIT LEAVING-AIR wB TEMP	_____	_____
COMPRESSOR 1 AMPS (L1/L2/L3)	_____ / _____ / _____	
COMPRESSOR 2 AMPS (L1/L2/L3)	_____ / _____ / _____	

NOTES:

38AUQ

CARRIER INDOOR UNIT
DIG-HVC-07-541

40RU
Packaged Air-Handling Units
60 Hz
with Puron® (R-410A) Refrigerant
Sizes: 07 – 16



Installation, Start-Up and Service Instructions

TABLE OF CONTENTS

<p>SAFETY CONSIDERATIONS 1</p> <p>PRE-INSTALLATION 2</p> <p style="padding-left: 20px;">Moving and Storage 2</p> <p style="padding-left: 20px;">Rigging 2</p> <p>INSTALLATION 2-23</p> <p style="padding-left: 20px;">General 2</p> <p style="padding-left: 20px;">Uncrating 2</p> <p style="padding-left: 20px;">Accessories 2</p> <p style="padding-left: 20px;">Rated Indoor Airflow (cfm) 11</p> <p style="padding-left: 20px;">Unit Positioning 12</p> <p style="padding-left: 20px;">Unit Isolation 13</p> <p style="padding-left: 20px;">Refrigerant and Chilled Water Piping Access 13</p> <p style="padding-left: 20px;">Refrigerant Piping 13</p> <p style="padding-left: 20px;">Chilled Water Piping 17</p> <p style="padding-left: 20px;">Condensate Drain 18</p> <p style="padding-left: 20px;">Fan Motors and Drives 18</p> <p style="padding-left: 20px;">Power Supply and Wiring 19</p> <p style="padding-left: 20px;">Connecting Ductwork 23</p> <p style="padding-left: 20px;">Return-Air Filters 23</p> <p>START-UP 24</p> <p>SERVICE 24-38</p> <p style="padding-left: 20px;">Panels 24</p> <p style="padding-left: 20px;">Fan Motor Lubrication 24</p> <p style="padding-left: 20px;">Fan Shaft Bearings 25</p> <p style="padding-left: 20px;">Centering Fan Wheel 25</p> <p style="padding-left: 20px;">Fan Shaft Position Adjustment 25</p> <p style="padding-left: 20px;">Individual Fan Wheel Adjustment 26</p> <p style="padding-left: 20px;">Fan Belts 26</p> <p style="padding-left: 20px;">Fan Rotation 26</p> <p style="padding-left: 20px;">Fan Pulley Alignment 26</p> <p style="padding-left: 20px;">Pulley and Drive Adjustment 26</p> <p style="padding-left: 20px;">Condensate Drains 26</p> <p style="padding-left: 20px;">Return-Air Filters 26</p>	<p style="padding-left: 20px;">Chilled Water Coil Freeze Protection 27</p> <p style="padding-left: 20px;">Coil Removal 27</p> <p style="padding-left: 20px;">Cleaning Cooling Coil 27</p> <p style="padding-left: 20px;">Cleaning Insulation 27</p> <p style="padding-left: 20px;">Replacing Filters 27</p> <p>START-UP CHECKLIST 39-40</p>
---	---

SAFETY CONSIDERATIONS

Improper installation, adjustment, alteration, service, maintenance, or use can cause explosion, fire, electrical shock or other conditions which may cause personal injury or property damage. Consult a qualified installer, service agency, or your distributor or branch for information or assistance. The qualified installer or agency must use factory-authorized kits or accessories when modifying this product. Refer to the individual instructions package

Follow all safety codes. Wear safety glasses and work gloves. Use quenching cloths for brazing operations and have a fire extinguisher available. Read these instructions thoroughly and follow all warnings or cautions attached to the unit. Consult local building codes and appropriate national electrical codes (in USA, ANSI/NFPA70, National Electrical Code (NEC); in Canada, CSA C22.1) for special requirements.

It is important to recognize safety information. This is the safety-alert symbol . When you see this symbol on the unit and in instructions or manuals, be alert to the potential for personal injury.

Understand the signal words DANGER, WARNING, CAUTION, and NOTE. These words are used with the safety-alert symbol. DANGER identifies the most serious hazards which **will** result in severe personal injury or death. WARNING signifies hazards which **could** result in personal injury or death. CAUTION is used to identify unsafe practices, which **may** result in minor personal injury or product and property damage. NOTE is used to highlight suggestions which **will** result in enhanced installation, reliability, or operation.

⚠ WARNING**ELECTRICAL SHOCK HAZARD**

Failure to follow this warning could cause personal injury or death.

Before performing service or maintenance operations on unit, turn off main power switch to unit and install lock(s) and lockout tag(s). Ensure electrical service to rooftop unit agrees with voltage and amperage listed on the unit rating plate. Unit may have more than one power switch.

⚠ WARNING**UNIT OPERATION AND SAFETY HAZARD**

Failure to follow this warning could cause in personal injury, death and/or equipment damage.

Puron® (R-410A) refrigerant systems operate at higher pressures than standard R-22 systems. Do not use R-22 service equipment or components on Puron refrigerant equipment.

⚠ WARNING**PERSONAL INJURY AND ENVIRONMENTAL HAZARD**

Failure to follow this warning could cause in personal injury or death.

Relieve pressure and recover all refrigerant before system repair or final unit disposal.

Wear safety glasses and gloves when handling refrigerants. Keep torches and other ignition sources away from refrigerants and oils.

⚠ CAUTION**CUT HAZARD**

Failure to follow this caution may result in personal injury.

Sheet metal parts may have sharp edges or burrs. Use care and wear appropriate protective clothing, safety glasses and gloves when handling parts and servicing 40RU units.

⚠ CAUTION**UNIT OPERATION HAZARD**

Failure to follow this caution could cause equipment damage.

Ensure voltage listed on unit data plate agrees with electrical supply provided for the unit.

PRE-INSTALLATION

1. The power supply (v, ph, and Hz) must correspond to that specified on unit rating plate.
2. The electrical supply provided by the utility must be sufficient to handle load imposed by this unit.
3. Refer to Installation, General section (page 2) and Fig. 1 and Fig. 2 for locations of electrical inlets, condensate drain, duct connections, and required clearances before setting unit in place.
4. This installation must conform with local building codes and with the NEC (National Electrical Code) or ANSI (American National Standards Institute)/NFPA (National Fire Protection Association) latest revision. Refer to provincial and local plumbing or wastewater codes and other applicable local codes.

Moving and Storage - To transfer unit from truck to storage site, use a fork truck. Do not stack units more than 2 high during storage. If unit is to be stored for more than 2 weeks before installation, choose a level, dry storage site free from vibration. Do not remove plastic wrap or skid from unit until final installation.

Rigging - All 40RU Series units can be rigged by using the shipping skid. Units are shipped fully assembled. Do not remove shipping skids or protective covering until unit is ready for final placement; damage to bottom panels can result. Use slings and spreader bars as applicable to lift unit.

INSTALLATION

General - Allow the following clearances for service access and airflow:

- Rear: 3 ft (914 mm) [2¹/₂ ft (762 mm) with electric heat accessory]
- Front: 2¹/₂ ft (762 mm)
- Right Side: 3¹/₂ ft (1067 mm)
- Left Side: 2¹/₂ ft (762 mm)

For units equipped with an economizer, refer to the accessory installation instructions for additional clearance requirements. Be sure floor, wall, or ceiling can support unit weight (Tables 1A – 1F). See Fig. 1 and Fig. 2 for dimensions.

Uncrating - Move unit as near as possible to final location before removing shipping skid.

Remove metal banding, top skid, and plastic wrap. Examine unit for shipping damage. If shipping damage is evident, file claim with transportation agency. Remove base skid just prior to actual installation.

Check nameplate information against available power supply and model number description in Fig. 3.

NOTE: Be sure to remove the styrofoam shipping pad from the thermostatic expansion valve (TXV). Verify that it has been removed. See Fig. 4.

Accessories - Refer to instructions shipped with each accessory for specific information.

Table 1A — 40RUA Physical Data, English — Cooling Units

UNIT 40RUA*	07	08	12	14	16
NOMINAL CAPACITY (Tons)	6	7 ¹ / ₂	10	12 ¹ / ₂	15
OPERATING WEIGHT (lb)					
Base Unit with TXV	399	404	425	695	713
Plenum	175	175	175	225	225
FANS					
Qty...Diam. (in.)	1...15	1...15	1...15	2...15	2...15
Nominal Airflow (cfm)	2400	3000	4000	5000	6000
Airflow Range (cfm)	1800–3000	2250–3750	3000–5000	3750–6250	4500–7500
Nominal Motor Hp (Standard Motor)					
208/230–1–60	1.3	2.4	—	—	—
208/230–3–60 and 460–3–60	2.4	2.4	2.4	2.9	3.7
575–3–60	1.0	2.0	2.0	3.0	3.0
Motor Speed (rpm)					
208/230–1–60	1725	1725	—	—	—
208/230–3–60 and 460–3–60	1725	1725	1725	1725	1725
575–3–60	1725	1725	1725	1725	1725
REFRIGERANT	R–410A	R–410A	R–410A	R–410A	R–410A
Operating charge (lb) (approx per circuit) [†]	3.0	3.0	1.5/1.5	2.0/2.0	2.5/2.5
DIRECT–EXPANSION COIL		Enhanced Copper Tubes, Aluminum Sine–Wave Fins			
Max Working Pressure (psig)	650	650	650	650	650
Face Area (sq ft)	6.67	8.33	10.0	13.25	17.67
No. of Splits	1	1	2	2	2
No. of Circuits per Split	12	15	9	12	16
Split Type...Percentage	—	—	Face...50/50	Face...50/50	Face...50/50
Rows...Fins/in.	4...15	4...15	4...15	4...15	4...15
PIPING CONNECTIONS,					
Quantity...Size (in.)					
DX Coil — Suction (ODF)	1...1 ¹ / ₈	1...1 ¹ / ₈	2...1 ¹ / ₈	2...1 ¹ / ₈	2...1 ¹ / ₈
DX Coil — Liquid Refrigerant (ODF)	1... ⁵ / ₈	1... ⁵ / ₈	2... ⁵ / ₈	2... ⁵ / ₈	2... ⁵ / ₈
Steam Coil, In (MPT)	1...2 ¹ / ₂	1...2 ¹ / ₂	1...2 ¹ / ₂	1...2 ¹ / ₂	1...2 ¹ / ₂
Steam Coil, Out (MPT)	1...1 ¹ / ₂	1...1 ¹ / ₂	1...1 ¹ / ₂	1...1 ¹ / ₂	1...1 ¹ / ₂
Hot Water Coil, In (MPT)	1...1 ¹ / ₂	1...1 ¹ / ₂	1...1 ¹ / ₂	1...2	1...2
Hot Water Coil, Out (MPT)	1...1 ¹ / ₂	1...1 ¹ / ₂	1...1 ¹ / ₂	1...2	1...2
Condensate (PVC)			1...1 ⁵ / ₈ ODM / 1 ¹ / ₄ IDF		
FILTERS		Throwaway — Factory Supplied			
Quantity...Size (in.)	4...16 x 24 x 2	4...16 x 24 x 2	4...16 x 24 x 2	4...16 x 20 x 2 4...16 x 24 x 2	4...16 x 20 x 2 4...16 x 24 x 2
Access Location	Either Side	Either Side	Either Side	Either Side	Either Side
STEAM COIL[‡]					
Max Working Pressure (psig at 260° F)	20	20	20	20	20
Total Face Area (sq ft)	6.67	6.67	6.67	13.33	13.33
Rows...Fins/in.	1...9	1...9	1...9	1...10	1...10
HOT WATER COIL[‡]					
Max Working Pressure (psig)	150	150	150	150	150
Total Face Area (sq ft)	6.67	6.67	6.67	13.33	13.33
Rows...Fins/in.	2...8.5	2...8.5	2...8.5	2...8.5	2...8.5
Water Volume					
(gal)	8.3	8.3	8.3	13.9	13.9
(ft ³)	1.1	1.1	1.1	1.85	1.85

LEGEND

- DX — Direct Expansion
- TXV — Thermostatic Expansion Valve
- † Units are shipped without refrigerant charge.
- ‡ Field installed accessory only.

40RU

Table 1B — 40RUA Physical Data, SI — Cooling Units

40RU

UNIT 40RUA*	07	08	12	14	16
NOMINAL CAPACITY (kW)	21	26	35	43	52
OPERATING WEIGHT (kg)					
Base Unit with TXV	181	183	193	315	323
Plenum	80	80	80	102	102
FANS					
Qty...Diam. (mm)	1...381	1...381	1...381	2...381	2...381
Nominal Airflow (L/s)	1133	1604	1888	2360	2831
Airflow Range (L/s)	850–1416	1203–2006	1416–2360	1770–2949	2124–3539
Nominal Motor kW (Standard Motor)					
208/230–1–60	0.97	1.79	—	—	—
208/230–3–60 and 460–3–60	1.79	1.79	1.79	2.16	2.16
575–3–60	0.75	1.49	1.49	2.24	2.24
Motor Speed (r/s)					
208/230–1–60	28.8	28.8	—	—	—
208/230–3–60 and 460–3–60	28.8	28.8	28.8	28.8	28.8
575–3–60	28.8	28.8	28.8	28.8	28.8
REFRIGERANT	R–410A	R–410A	R–410A	R–410A	R–410A
Operating charge (kg) (approx per circuit) [†]	1.36	1.36	0.68/0.68	0.90/0.90	1.13/1.13
DIRECT–EXPANSION COIL	Enhanced Copper Tubes, Aluminum Sine–Wave Fins				
Max Working Pressure (kPag)	4481	4481	4481	4481	4481
Face Area (sq m)	0.62	0.77	0.93	0.93	1.64
No. of Splits	1	1	2	2	2
No. of Circuits per Split	12	15	9	12	16
Split Type...Percentage	—	—	Face...50/50	Face...50/50	Face...50/50
Rows...Fins/m	4...591	4...591	4...591	4...591	4...591
PIPING CONNECTIONS,					
Quantity...Size (in.)					
DX Coil — Suction (ODF)	1...1 ¹ / ₈	1...1 ¹ / ₈	2...1 ¹ / ₈	2...1 ¹ / ₈	2...1 ¹ / ₈
DX Coil — Liquid Refrigerant (ODF)	1... ⁵ / ₈	1... ⁵ / ₈	2... ⁵ / ₈	2... ⁵ / ₈	2... ⁵ / ₈
Steam Coil, In (MPT)	1...2 ¹ / ₂	1...2 ¹ / ₂	1...2 ¹ / ₂	1...2 ¹ / ₂	1...2 ¹ / ₂
Steam Coil, Out (MPT)	1...1 ¹ / ₂	1...1 ¹ / ₂	1...1 ¹ / ₂	1...1 ¹ / ₂	1...1 ¹ / ₂
Hot Water Coil, In (MPT)	1...1 ¹ / ₂	1...1 ¹ / ₂	1...1 ¹ / ₂	1...2	1...2
Hot Water Coil, Out (MPT)	1...1 ¹ / ₂	1...1 ¹ / ₂	1...1 ¹ / ₂	1...2	1...2
Condensate (PVC)	1...1 ⁵ / ₈ ODM / 1 ¹ / ₄ IDF				
FILTERS	Throwaway — Factory Supplied				
Quantity...Size (mm)	4...406 x 610 x 51			4...406 x 508 x 51 4...406 x 610 x 51	
Access Location	Either Side			Either Side	
STEAM COIL[‡]					
Max Working Pressure (kPag at 126° C)	138	138	138	138	138
Total Face Area (sq m)	0.62	0.62	0.62	1.24	1.24
Rows...Fins/m	1...355	1...355	1...355	1...394	1...394
HOT WATER COIL[‡]					
Max Working Pressure (kPag)	1034	1034	1034	1034	1034
Total Face Area (sq m)	0.62	0.62	0.62	1.24	1.24
Rows...Fins/m	2...335	2...335	2...335	2...335	2...335
Water Volume					
(L)	31.4	31.4	31.4	52.6	52.6
(m ³)	0.031	0.031	0.031	0.052	0.052

LEGEND

- DX — Direct Expansion
- TXV — Thermostatic Expansion Valve
- † Units are shipped without refrigerant charge.
- ‡ Field installed accessory only.

Table 1C — 40RUQ Physical Data, English — Heat Pump Units

UNIT 40RUQ*	07	07T	08	12	16
NOMINAL CAPACITY (Tons)	6	6	7 ¹ / ₂	10	15
OPERATING WEIGHT (lb)					
Base Unit with TXV	381	381	385	427	713
Plenum	175	175	175	175	225
FANS					
Qty...Diam. (in.)	1...15	1...15	1...15	1...15	2...15
Nominal Airflow (cfm)	2400	2400	3000	4000	6000
Airflow Range (cfm)	1800–3000	1800–3000	2250–3750	3000–5000	4500–7500
Nominal Motor Hp (Standard Motor)					
208/230–1–60	1.3	1.3	2.4	—	—
208/230–3–60 and 460–3–60	2.4	2.4	2.4	2.4	3.7
575–3–60	1.0	1.0	2.0	2.0	3.0
Motor Speed (rpm)					
208/230–1–60	1725	1725	1725	—	—
208/230–3–60 and 460–3–60	1725	1725	1725	1725	1725
575–3–60	1725	1725	1725	1725	1725
REFRIGERANT	R–410A	R–410A	R–410A	R–410A	R–410A
Operating charge (lb) (approx per circuit) [†]	3.0	3.0	3.0	2.0/2.0	3.0/3.0
DIRECT–EXPANSION COIL	Enhanced Copper Tubes, Aluminum Sine–Wave Fins				
Max Working Pressure (psig)	650	650	650	650	650
Face Area (sq ft)	8.33	8.33	8.33	10.0	16.56
No. of Splits	1	1	1	2	2
No. of Circuits per Split	15	12	12	9	10
Split Type...Percentage	—	—	—	Face...50/50	Face...50/50
Rows...Fins/in.	3...15	4...15	4...15	4...15	4...15
PIPING CONNECTIONS,					
Quantity...Size (in.)					
DX Coil — Suction (ODF)	1...1 ¹ / ₈	1...1 ¹ / ₈	1...1 ¹ / ₈	2...1 ¹ / ₈	2...1 ¹ / ₈
DX Coil — Liquid Refrigerant (ODF)	1... ⁵ / ₈	1... ⁵ / ₈	1... ⁵ / ₈	2... ⁵ / ₈	2... ⁵ / ₈
Steam Coil, In (MPT)	1...2 ¹ / ₂	1...2 ¹ / ₂	1...2 ¹ / ₂	1...2 ¹ / ₂	1...2 ¹ / ₂
Steam Coil, Out (MPT)	1...1 ¹ / ₂	1...1 ¹ / ₂	1...1 ¹ / ₂	1...1 ¹ / ₂	1...1 ¹ / ₂
Hot Water Coil, In (MPT)	1...1 ¹ / ₂	1...1 ¹ / ₂	1...1 ¹ / ₂	1...1 ¹ / ₂	1...2
Hot Water Coil, Out (MPT)	1...1 ¹ / ₂	1...1 ¹ / ₂	1...1 ¹ / ₂	1...1 ¹ / ₂	1...2
Condensate (PVC)	1...1 ⁵ / ₈ ODM / 1 ¹ / ₄ IDF				
FILTERS	Throwaway — Factory Supplied				
Quantity...Size (in.)	4...16 x 24 x 2	4...16 x 24 x 2	4...16 x 24 x 2	4...16 x 24 x 2	4...16 x 20 x 2 4...16 x 24 x 2
Access Location	Either Side	Either Side	Either Side	Either Side	Either Side
STEAM COIL[‡]					
Max Working Pressure (psig at 260° F)	20	20	20	20	20
Total Face Area (sq ft)	6.67	6.67	6.67	6.67	13.33
Rows...Fins/in.	1...9	1...9	1...9	1...9	1...10
HOT WATER COIL[‡]					
Max Working Pressure (psig)	150	150	150	150	150
Total Face Area (sq ft)	6.67	6.67	6.67	6.67	13.33
Rows...Fins/in.	2...8.5	2...8.5	2...8.5	2...8.5	2...8.5
Water Volume					
(gal)	8.3	8.3	8.3	8.3	13.9
(ft ³)	1.1	1.1	1.1	1.1	1.85

40RU

LEGEND

- DX — Direct Expansion
- TXV — Thermostatic Expansion Valve
- † Units are shipped without refrigerant charge.
- ‡ Field installed accessory only.

Table 1D — 40RUQ Physical Data, SI — Heat Pump Units

40RU

UNIT 40RUQ*	07	07T	08	12	16
NOMINAL CAPACITY (kW)	21	21	26	35	52
OPERATING WEIGHT (kg)					
Base Unit with TXV	173	173	175	194	323
Plenum	80	80	80	80	102
FANS					
Qty...Diam. (mm)	1...381	1...381	1...381	1...381	2...381
Nominal Airflow (L/s)	1133	1133	1604	1888	2831
Airflow Range (L/s)	850–1416	850–1416	1203–2006	1416–2360	2124–3539
Nominal Motor kW (Standard Motor)					
208/230–1–60	0.97	0.97	1.79	—	—
208/230–3–60 and 460–3–60	1.79	1.79	1.79	1.79	2.76
575–3–60	0.75	0.75	1.49	1.49	2.24
Motor Speed (r/s)					
208/230–1–60	28.8	28.8	28.8	—	—
208/230–3–60 and 460–3–60	28.8	28.8	28.8	28.8	28.8
575–3–60	28.8	28.8	28.8	28.8	28.8
REFRIGERANT	R-410A	R-410A	R-410A	R-410A	R-410A
Operating charge (kg) (approx per circuit) [†]	1.36	1.36	1.36	0.91/0.91	1.36/1.36
DIRECT-EXPANSION COIL	Enhanced Copper Tubes, Aluminum Sine-Wave Fins				
Max Working Pressure (kPag)	4482	4482	4482	4482	4482
Face Area (sq m)	0.77	0.77	0.77	0.93	1.54
No. of Splits	1	1	1	2	2
No. of Circuits per Split	15	12	12	9	10
Split Type...Percentage	—	—	—	Face...50/50	Face...50/50
Rows...Fins/m	3...591	4...591	4...591	3...591	4...591
PIPING CONNECTIONS,					
Quantity...Size (in.)					
DX Coil — Suction (ODF)	1...1 ¹ / ₈	1...1 ¹ / ₈	1...1 ¹ / ₈	2...1 ¹ / ₈	2...1 ¹ / ₈
DX Coil — Liquid Refrigerant (ODF)	1... ⁵ / ₈	1... ⁵ / ₈	1... ⁵ / ₈	2... ⁵ / ₈	2... ⁵ / ₈
Steam Coil, In (MPT)	1...2 ¹ / ₂	1...2 ¹ / ₂	1...2 ¹ / ₂	1...2 ¹ / ₂	1...2 ¹ / ₂
Steam Coil, Out (MPT)	1...1 ¹ / ₂	1...1 ¹ / ₂	1...1 ¹ / ₂	1...1 ¹ / ₂	1...1 ¹ / ₂
Hot Water Coil, In (MPT)	1...1 ¹ / ₂	1...1 ¹ / ₂	1...1 ¹ / ₂	1...1 ¹ / ₂	1...2
Hot Water Coil, Out (MPT)	1...1 ¹ / ₂	1...1 ¹ / ₂	1...1 ¹ / ₂	1...1 ¹ / ₂	1...2
Condensate (PVC)				1...1 ⁵ / ₈ ODM / 1 ¹ / ₄ IDF	
FILTERS	Throwaway — Factory Supplied				
Quantity...Size (mm)	4...406 x 610 x 51	4...406 x 610 x 51	4...406 x 610 x 51	4...406 x 610 x 51	4...406 x 508 x 51 4...406 x 610 x 51
Access Location	Either Side	Either Side	Either Side	Either Side	Either Side
STEAM COIL[‡]					
Max Working Pressure (kPag at 126° C)	138	138	138	138	138
Total Face Area (sq m)	0.62	0.62	0.62	0.62	1.24
Rows...Fins/m	1...355	1...355	1...355	1...355	1...394
HOT WATER COIL[‡]					
Max Working Pressure (kPag)	1034	1034	1034	1034	1034
Total Face Area (sq m)	0.62	0.62	0.62	0.62	1.24
Rows...Fins/m	2...335	2...335	2...335	2...335	2...335
Water Volume					
(L)	31.4	31.4	31.4	31.4	52.6
(m ³)	0.031	0.031	0.031	0.031	0.052

LEGEND

- DX — Direct Expansion
- TXV — Thermostatic Expansion Valve
- † Units are shipped without refrigerant charge.
- ‡ Field installed accessory only.

Table 1E — 40RUS Physical Data, English — Chilled Water Units

UNIT 40RUS*	08	10	12	14	16
NOMINAL CAPACITY (Tons)	7 ¹ / ₂	8 ¹ / ₂	10	12 ¹ / ₂	15
OPERATING WEIGHT (lb)					
Base Unit	390	391	391	661	677
Plenum	175	175	175	225	225
FANS					
Qty...Diam. (in.)	1...15	1...15	1...15	2...15	2...15
Nominal Airflow (cfm)	3000	3400	4000	5000	6000
Airflow Range (cfm)	2250–3750	2250–4250	3000–5000	3750–6250	4500–7500
Nominal Motor Hp (Standard Motor)					
208/230–1–60	2.4	2.4	—	—	—
208/230–3–60 and 460–3–60	2.4	2.4	2.4	2.9	3.7
575–3–60	2.0	2.0	2.0	3.0	3.0
Motor Speed (rpm)					
208/230–1–60	1725	1725	—	—	—
208/230–3–60 and 460–3–60	1725	1725	1725	1725	1725
575–3–60	1725	1725	1725	1725	1725
CHILLED WATER COIL	Enhanced Copper Tubes, Aluminum Sine-Wave Fins				
Max Working Pressure (psig)	435	435	435	435	435
Face Area (sq ft) – Upper	8.3	9.0	9.9	8.3	8.3
Face Area (sq ft) – Lower	—	—	—	5.5	8.3
Rows...Fins/in.	3...15	3...15	3...15	3...15	3...15
PIPING CONNECTIONS, Quantity...Size (in.)					
Chilled Water — In	1...1 ³ / ₈ ODF	1...1 ³ / ₈ ODF	1...1 ³ / ₈ ODF	2...1 ³ / ₈ ODM	2...1 ³ / ₈ ODM
Chilled Water — Out	1...1 ³ / ₈ ODF	1...1 ³ / ₈ ODF	1...1 ³ / ₈ ODF	2...1 ³ / ₈ ODM	2...1 ³ / ₈ ODM
Steam Coil, In (MPT)	1...2 ¹ / ₂	1...2 ¹ / ₂	1...2 ¹ / ₂	1...2 ¹ / ₂	1...2 ¹ / ₂
Steam Coil, Out (MPT)	1...1 ¹ / ₂	1...1 ¹ / ₂	1...1 ¹ / ₂	1...1 ¹ / ₂	1...1 ¹ / ₂
Hot Water Coil, In (MPT)	1...1 ¹ / ₂	1...1 ¹ / ₂	1...1 ¹ / ₂	1...2	1...2
Hot Water Coil, Out (MPT)	1...1 ¹ / ₂	1...1 ¹ / ₂	1...1 ¹ / ₂	1...2	1...2
Condensate (PVC)	1...1 ⁵ / ₈ ODM / 1 ¹ / ₄ IDF				
FILTERS	Throwaway — Factory Supplied				
Quantity...Size (in.)	4...16 x 24 x 2	4...16 x 24 x 2	4...16 x 24 x 2	4...16 x 20 x 2 4...16 x 24 x 2	4...16 x 20 x 2 4...16 x 24 x 2
Access Location	Either Side	Either Side	Either Side	Either Side	Either Side
STEAM COIL[‡]					
Max Working Pressure (psig at 260°F)	20	20	20	20	20
Total Face Area (sq ft)	6.67	6.67	6.67	13.33	13.33
Rows...Fins/in.	1...9	1...9	1...9	1...9	1...10
HOT WATER COIL[‡]					
Max Working Pressure (psig)	150	150	150	150	150
Total Face Area (sq ft)	6.67	6.67	6.67	13.33	13.33
Rows...Fins/in.	2...8.5	2...8.5	2...8.5	2...8.5	2...8.5
Water Volume					
(gal)	8.3	8.3	8.3	13.9	13.9
(ft ³)	1.1	1.1	1.1	1.85	1.85

LEGEND
[‡] Field installed accessory only.

40RU

Table 1F — 40RUS Physical Data, SI — Chilled Water Units

40RU

UNIT 40RUS*	08	10	12	14	16
NOMINAL CAPACITY (kW)	26	29	35	43	52
OPERATING WEIGHT (kg)					
Base Unit	177	177	177	300	307
Plenum	80	80	80	102	102
FANS					
Qty...Diam. (mm)	1...381	1...381	1...381	2...381	2...381
Nominal Airflow (L/s)	1416	1605	1888	2360	2831
Airflow Range (L/s)	1062–1770	1204–2006	1416–2360	1770–2949	2124–3539
Nominal Motor kW (Standard Motor)					
208/230–1–60	1.79	1.79	—	—	—
208/230–3–60 and 460–3–60	1.79	1.79	1.79	1.79	2.76
575–3–60	1.49	1.49	1.49	1.49	2.24
Motor Speed (r/s)					
208/230–1–60	28.8	28.8	—	—	—
208/230–3–60 and 460–3–60	28.8	28.8	28.8	28.8	28.8
575–3–60	28.8	28.8	28.8	28.8	28.8
CHILLED WATER COIL	Enhanced Copper Tubes, Aluminum Sine-Wave Fins				
Max Working Pressure (kPag)	2999	2999	2999	2999	2999
Face Area (sq m) – Upper	0.77	0.84	0.91	0.77	0.77
Face Area (sq m) – Lower	—	—	—	0.51	0.77
Rows...Fins/m	3...591	3...591	3...591	3...591	3...591
PIPING CONNECTIONS, Quantity...Size (in.)					
Chilled Water — In	1...1 ³ / ₈ ODF	1...1 ³ / ₈ ODF	1...1 ³ / ₈ ODF	2...1 ³ / ₈ ODM	2...1 ³ / ₈ ODM
Chilled Water — Out	1...1 ³ / ₈ ODF	1...1 ³ / ₈ ODF	1...1 ³ / ₈ ODF	2...1 ³ / ₈ ODM	2...1 ³ / ₈ ODM
Steam Coil, In (MPT)	1...2 ¹ / ₂	1...2 ¹ / ₂	1...2 ¹ / ₂	1...2 ¹ / ₂	1...2 ¹ / ₂
Steam Coil, Out (MPT)	1...1 ¹ / ₂	1...1 ¹ / ₂	1...1 ¹ / ₂	1...1 ¹ / ₂	1...1 ¹ / ₂
Hot Water Coil, In (MPT)	1...1 ¹ / ₂	1...1 ¹ / ₂	1...1 ¹ / ₂	1...2	1...2
Hot Water Coil, Out (MPT)	1...1 ¹ / ₂	1...1 ¹ / ₂	1...1 ¹ / ₂	1...2	1...2
Condensate (PVC)	1...1 ⁵ / ₈ ODM / 1 ¹ / ₄ IDF				
FILTERS	Throwaway — Factory Supplied				
Quantity...Size (mm)	4...406 x 610 x 51			4...406 x 508 x 51 4...406 x 610 x 51	
Access Location	Either Side			Either Side	
STEAM COIL[‡]					
Max Working Pressure (kPag at 125° C)	138	138	138	138	138
Total Face Area (sq m)	0.62	0.62	0.62	1.24	1.24
Rows...Fins/m	1...355	1...355	1...355	1...355	1...394
HOT WATER COIL[‡]					
Max Working Pressure (kPag)	1034	1034	1034	1034	1034
Total Face Area (sq m)	0.62	0.62	0.62	1.24	1.24
Rows...Fins/m	2...335	2...335	2...335	2...335	2...335
Water Volume					
(L)	31.4	31.4	31.4	52.6	52.6
(m ³)	0.031	0.031	0.031	0.052	0.052

LEGEND
[‡] Field installed accessory only.

UNIT	UNIT WEIGHT (W/TXV)
40RUA-07	399 lbs [181 kg]
40RUA-08	404 lbs [183 kg]
40RUA-12	425 lbs [193 kg]
40RUO-07	381 lbs [173 kg]
40RUO-08	385 lbs [175 kg]
40RUO-12	427 lbs [194 kg]
40RUS-08	390 lbs [177 kg]
40RUS-10	391 lbs [177 kg]
40RUS-12	391 lbs [177 kg]



UNITED TECHNOLOGIES SYRACUSE, NY
CARRIER P.O. BOX 4808 13221

THIS DOCUMENT IS THE PROPERTY OF CARRIER CORPORATION AND IS DELIVERED UPON THE EXPRESS CONDITION THAT THE CONTENTS WILL NOT BE DISCLOSED OR USED WITHOUT CARRIER CORPORATION'S WRITTEN CONSENT.

SUBMISSION OF THESE DRAWINGS OR DOCUMENTS DOES NOT CONSTITUTE PART PERFORMANCE OR ACCEPTANCE OF CONTRACT.

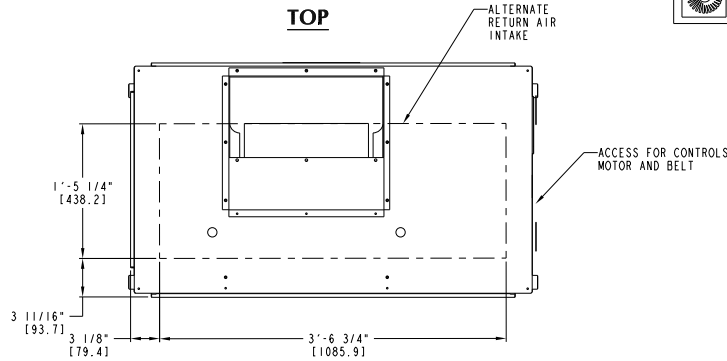

- NOTES:
1. DIMENSIONS IN [] ARE IN MILLIMETERS.
 2. DIRECTIONS OF AIRFLOW.
 3. RECOMMENDED CLEARANCE:
REAR: 2 ft 6 in. [762 mm]
FRONT: 2 ft 6 in. [762 mm]
RIGHT SIDE: 2 ft 6 in. [762 mm]
LEFT SIDE: 2 ft 6 in. [762 mm]
LOCAL CODES OR JURISDICTION MAY PREVAIL.
 4. LIQUID PIPING NOT SUPPLIED BY CARRIER.
 5. DUCT FLANGE IS FACTORY SUPPLIED AND FIELD INSTALLED.

ACCESSORY	SEE DRAWING
DISCHARGE PLENUM	40RM500996
ECONOMIZER	40RM500999
STEAM COIL	40RM500999
HOT WATER COIL	40RM500999
RETURN AIR GRILLE	40RM500996
OVERHEAD SUSPENSION	40RM500996
SUBBASE	40RM500996
ELECTRIC HEAT	40RM501002

UNRELEASED DATA

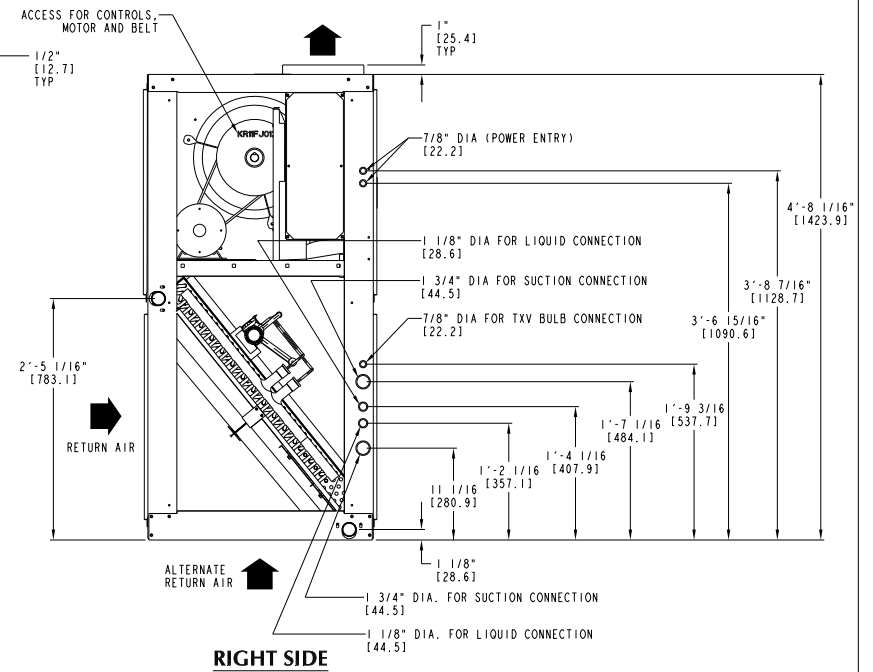
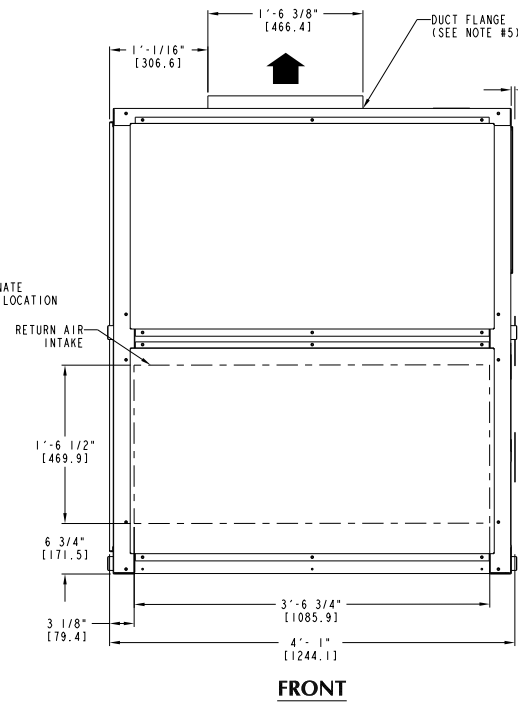
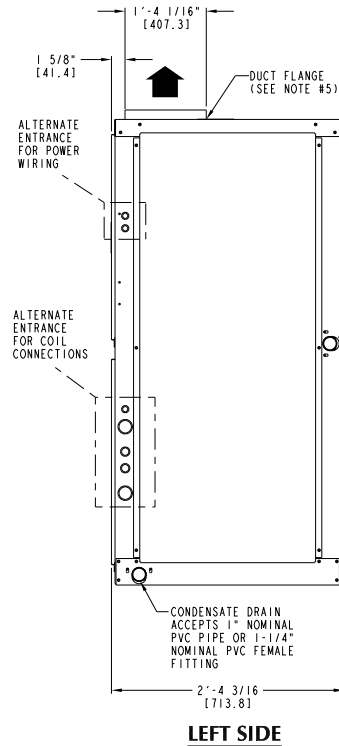

DATE	SUPERCEDES	FAN COIL UNITS	REV
01/23/12	04/21/10	40RU A / Q / S - 07 / 08 / 10 / 12	F

Fig. 1 - Dimensions - Sizes 07 - 12





UNITED TECHNOLOGIES CARRIER P.O. BOX 4808 SYRACUSE, NY 13221

THIS DOCUMENT IS THE PROPERTY OF CARRIER CORPORATION AND IS DELIVERED UPON THE EXPRESS CONDITION THAT THE CONTENTS WILL NOT BE DISCLOSED OR USED WITHOUT CARRIER CORPORATION'S WRITTEN CONSENT.

SUBMISSION OF THESE DRAWINGS OR DOCUMENTS DOES NOT CONSTITUTE PART PERFORMANCE OR ACCEPTANCE OF CONTRACT.

UNIT	UNIT WEIGHT (W/TXV)
40RUA-14	695 lbs [315 kg]
40RUA-16	713 lbs [323 kg]
40RUA-25	730 lbs [331 kg]
40RUO-16	713 lbs [323 kg]
40RUO-25	720 lbs [327 kg]
40RUS-14	661 lbs [300 kg]
40RUS-16	677 lbs [307 kg]
40RUS-25	683 lbs [310 kg]

TOP

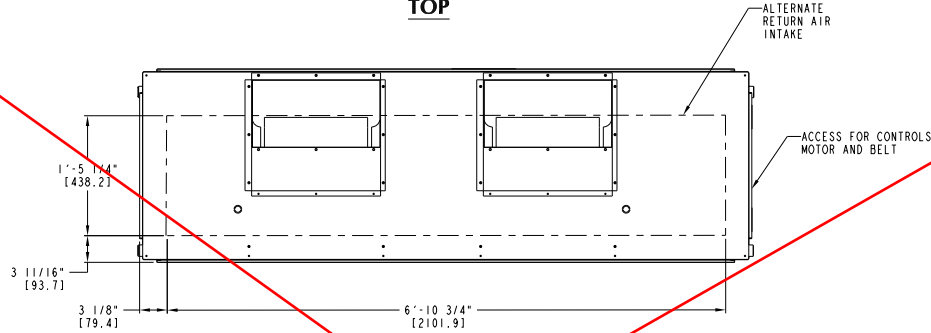

- NOTES:
1. DIMENSIONS IN [] ARE IN MILLIMETERS.
 2. DIRECTIONS OF AIRFLOW.
 3. RECOMMENDED CLEARANCE:
 REAR: 2 ft 6 in. [762 mm]
 FRONT: 2 ft 6 in. [762 mm]
 RIGHT SIDE: 2 ft 6 in. [762 mm]
 LEFT SIDE: 2 ft 6 in. [762 mm]
 LOCAL CODES OR JURISDICTION MAY PREVAIL.
 4. LIQUID PIPING NOT SUPPLIED BY CARRIER.
 5. DUCT FLANGE IS FACTORY SUPPLIED AND FIELD INSTALLED.

ACCESSORY	SEE DRAWING
DISCHARGE PLENUM	40RMS00997
ECONOMIZER	40RMS01000
STEAM COIL	40RMS01000
HOT WATER COIL	40RMS01000
RETURN AIR GRILLE	40RMS00997
OVERHEAD SUSPENSION	40RMS00997
SUBBASE	40RMS00997
ELECTRIC HEAT	40RMS01002

UNRELEASED DATA

FRONT

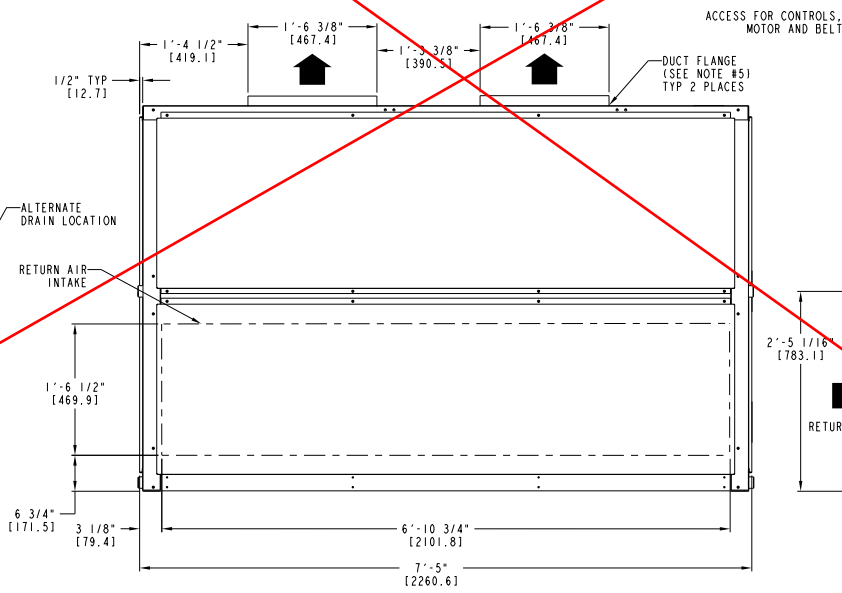

LEFT SIDE

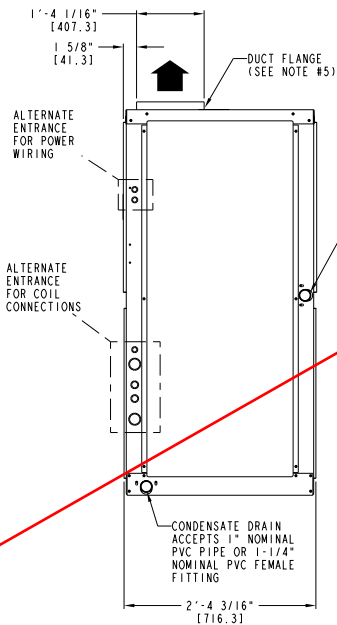

RIGHT SIDE

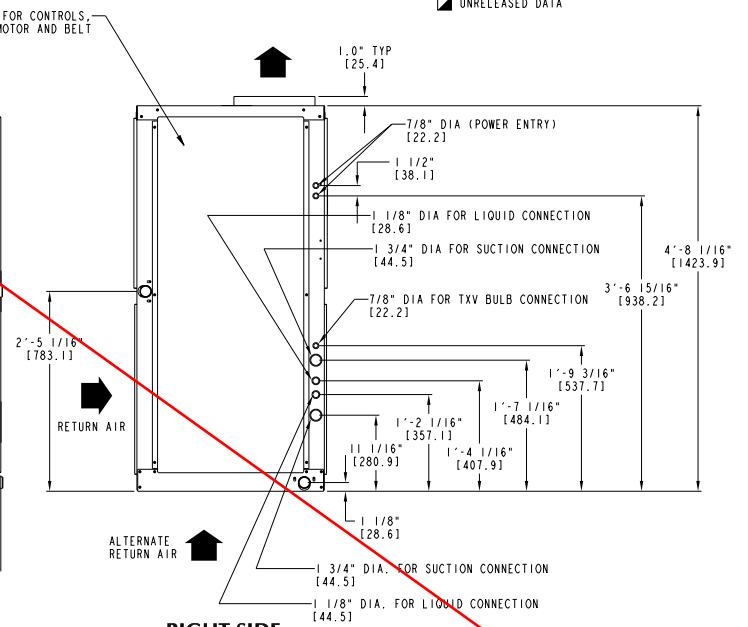

DATE	SUPERCEDES	FAN COIL UNITS	REV
01/23/12	04/21/10	40RU A / O / S - 14 / 16 / 25	F

Fig. 2 - Dimensions - Sizes 14 and 16

Rated Indoor Airflow (cfm)

The following tables list the rated indoor airflow used for the AHRI efficiency rating for the units covered in this document.

38AUZ with 40RUA

Model Number	Full Load Airflow (cfm)
38AUZA/B07 – 40RUA*07	2400
38AUZD/E07 – 40RUA*07	2625
38AUZA/B08 – 40RUA*08	3000
38AUZD/E08 – 40RUA*08	3000
38AUZ*12 – 40RUA*12	4000
38AUZ*14 – 40RUA*14	4375
38AUZ*16 – 40RUA*16	6000

38AUD with 40RUA

Model Number	Full Load Airflow (cfm)
38AUD*12 – 40RUA*12	4000
38AUD*14 – 40RUA*14	4400
38AUD*16 – 40RUA*16	6000

38AUQ with 40RUQ

Model Number	Full Load Airflow (cfm)
38AUQA/B07 – 40RUQ*07	2400
38AUQD/E07 – 40RUQ*07	2400
38AUQA/B08 – 40RUQ*08	3000
38AUQD/E08 – 40RUQ*08	2625
38AUDA/B12 – 40RUQ*12	3000
38AUDD/E12 – 40RUQ*12	3000
38AUQ*6 – 40RUQ*16	6000

Position	1	2	3	4	5	6	7	8	9	10	11	12	13	14	15	16	17	18
Example	4	0	R	U	A	A	1	2	A	1	A	6	-	0	A	0	A	0

<p>Model Type 40RU = Packaged Air Handling Unit with Puron® R-410A Refrigerant</p>	<p>Packaging 0 = Standard</p>
<p>Type of Coil A = Standard DX Coil Q = DX Coil for Heat Pump Duty S = Chilled Water Coil</p>	<p>Future Use A = Standard</p>
<p>Refrigerant Options A = None</p>	<p>Cabinet Paint 0 = None 1 = Painted</p>
<p>Nominal Tonnage 07 = 6 Tons (40RUA and 40RUQ only) 08 = 7.5 Tons 10 = 8.5 Tons (40RUS only) 12 = 10 Tons 14 = 12.5 Tons (40RUA and 40RUS only) 16 = 15 Tons</p>	<p>Future Use A = Standard</p>
<p>Fan Motor Speed Controller A = None - Standard T = 2 Speed Fan Controller (VFD) - Staged Air Volume (SAV™)</p>	<p>Future Use 0 = Standard</p>
<p>Indoor Fan Motor Options - Belt Drive 1 = Standard Motor / Standard Drive 2 = Standard/Alternate Motor / Medium Drive 3 = High Motor / High Drive ** 6 = High Static, High Efficient Motor / High Drive (16 size only)</p>	<p>Revision Number - = Standard</p>
	<p>Voltage* 1 = 575/3/60 3 = 208/230-1-60 (07, 08 and 10 sizes only) 5 = 208/230/3/60 6 = 460/3/60</p>
	<p>Coil Options A = Standard Aluminum Fin / Copper Tube</p>

Notes:

** Single-phase 07, 08 and 10 sizes designate standard motor and high static drive.

* All 40RU*07 through 14 units and 40RUQ07 through 16 units with a "6" voltage designation are triple voltage; i.e., 308/230/460-3-60. Size 40RU*16 is also triple voltage in the "6" configuration unless the High Static motor option is used that is discrete 460-3-60.

Units that require 2-Speed indoor fan motor must use dedicated voltage models listed. The VFD used is not multi voltage.

Fig. 3 - Model Number Nomenclature

C160030

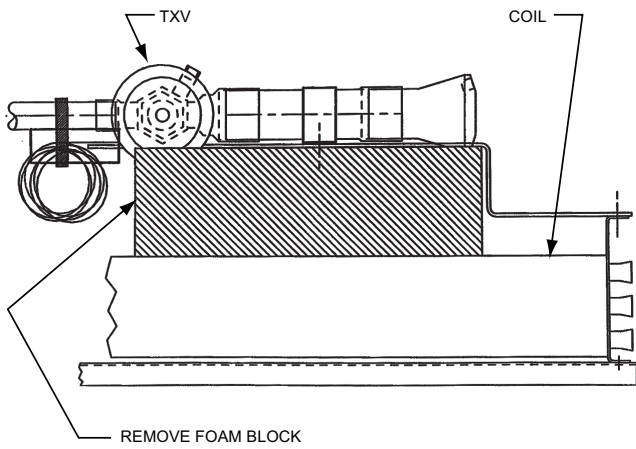

LEGEND
TXV — Thermostatic Expansion Valve

Fig. 4 - Foam Block Location

C10683

Unit Positioning - The unit can be mounted on the floor for vertical application with return air entering the face of the unit and supply air discharging vertically through the top of the unit. The unit can also be applied in a horizontal arrangement with return air entering horizontally and the supply air discharging horizontally. When applying the unit in a horizontal arrangement, ensure the condensate drain pan is located at the bottom center of the unit for adequate condensate disposal. See Fig. 5 for condensate connections for each unit position.

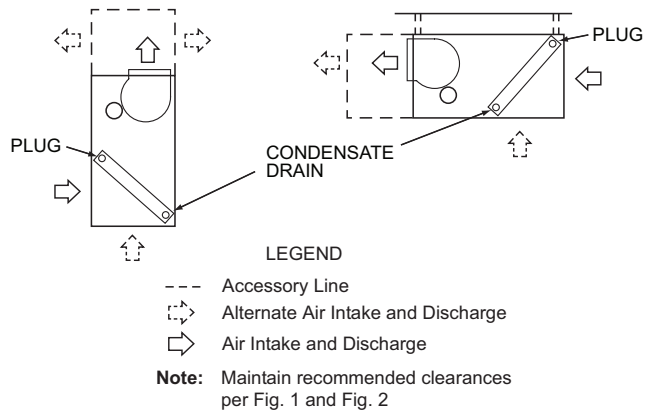

Fig. 5 - Typical Unit Positioning

C10684

IMPORTANT: Do NOT attempt to install unit with return air entering top panel of unit. Condensate will not drain from unit.

Typical positioning and alternate return air locations are shown in Fig. 5. Alternate return air locations can be used by moving the unit panel from the alternate return air location to the standard return air location. Refer to overhead suspension accessory drawing (Fig. 6) for preferred suspension technique. The unit needs support underneath to prevent sagging.

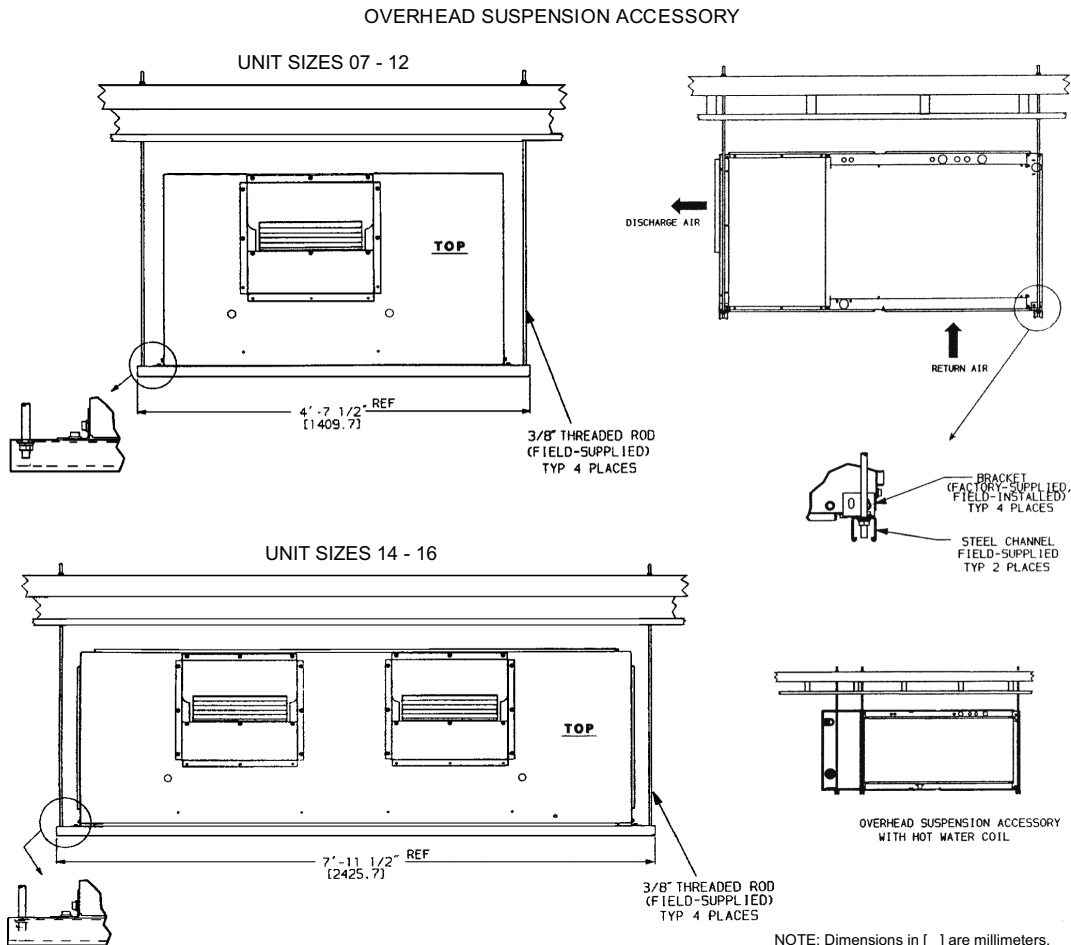

Fig. 6 - Preferred Suspension Technique

C10685

Unit Isolation - Where extremely quiet operation is essential, install isolators between floor and base of unit, or between ceiling and top section of unit.

Be sure that unit is level and adequately supported. Use channels at front and sides of unit for reference points when leveling.

IMPORTANT: Do not bury refrigerant piping underground.

Refrigerant Piping - See Tables 1A–1F for refrigerant pipe connection sizes. For ease in brazing, it is recommended that all internal solder joints be made before unit is placed in final position.

The 40RU direct-expansion units have internal factory-installed thermostatic expansion valves (TXVs), distributors, and nozzles for use with R-410A. See Table 2 for part numbers. Knockouts are provided in the unit corner posts for 40RU refrigerant piping. See Fig. 7, which also lists recommended knockouts and access holes to use for each 40RU unit size. Recommended fittings are listed in Table 3.

The sensor bulb capillary tubes must be routed from the TXVs inside the unit through one of the piping access holes. Clamp the TXV sensor bulb on a vertical portion of the suction line, outside the unit. See Fig. 8.

Refrigerant and Chilled Water Piping Access - The 40RU Series units come with standard knockouts for refrigerant and chilled water piping. These knockouts are

located on both sides of the unit for installation flexibility. The standard knockouts provide sufficient access to the unit's coils for all 40RUA*07, 08, 12, 14, 16 and 40RUQ*07, 08, 12 units. 40RUQ*16 units, as well as 40RUS*08, 12, 14, and 16 units require additional holes which must be field-fabricated to accommodate the piping. See Fig. 7 for positions and dimensions of the additional access holes required for the 40RUQ*16 and 40RUS units. Recommended access hole use is also listed for all units. Note that Fig. 7 shows the access holes on the control-box side of the unit; this is the side of the unit with the coil headers, so it is used most often for piping access.

NOTE: Be sure to remove the styrofoam shipping pad from the TXV. Verify that it has been removed. See Fig. 4.

IMPORTANT: Never attach the sensor to the suction manifold. Do NOT mount the sensor on a trapped portion of the suction line.

The 40RU Series evaporator coils have a face-split design. Ensure that lower circuit of coil is first on/last off when connected to the condensing unit and/or system controls. See Fig. 9.

External TXV equalizer connections are provided and factory-brazed into the coil suction manifolds.

If suction line must be horizontal, clamp bulb to suction line at least 45 degrees above bottom, at approximately the 4 o'clock or 8 o'clock position. See Fig. 10.

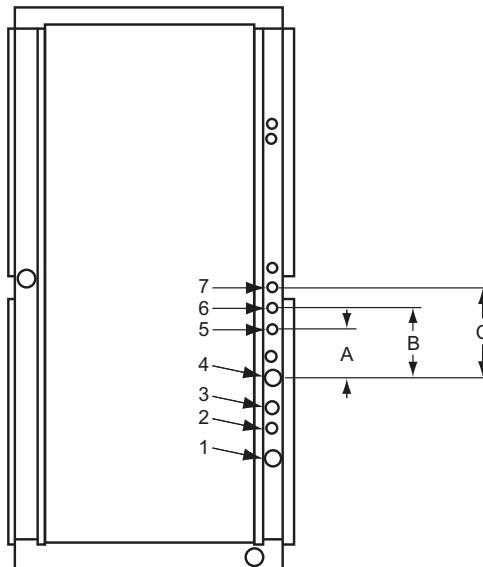

C10686

UNIT	USE HOLE NUMBERS	FIELD-FABRICATED HOLE DIAMETERS in. (mm)			FIELD-FABRICATED HOLE POSITION DIMENSIONS. in. (mm)		
		No. 5	No. 6	No. 7	A	B	C
40RUA*07, 08 40RUQ*07, 08	1, 3	—	—	—	—	—	—
40RUA*12, 14, 16 40RUQ12	1, 2, 3, 4	—	—	—	—	—	—
40RUS*08, 10, 12	4, 5	1 ³ / ₄ (44.5)	—	—	6.25 (158.8)	—	—
40RUS*14, 16	4, 5, 6, 7	1 ³ / ₄ (44.5)	1 ³ / ₄ (44.5)	1 ³ / ₄ (44.5)	3.0 (76.2)	6.0 (152.5)	10.5 (266.7)
40RUQ*16	3 [†] , 5, 6, 7	1 ¹ / ₈ (28.6)	1 ¹ / ₈ (28.6)	1 ³ / ₄ (44.5)	3.25 (82.6)	6.125 (155.6)	10.38 (263.7)

[†] Must be enlarged from 1¹/₈ in. (28.6mm) to 1³/₄ in. (44.5mm)

NOTE: Access hole knockouts 1–4 are factory-supplied.

Fig. 7 - Refrigerant and Chilled Water Piping Access Holes

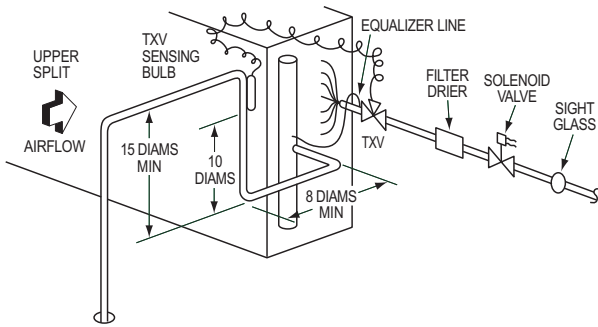

Single Circuit Coil Piping Configuration - RU*07, 08
For single compressor condensing units.

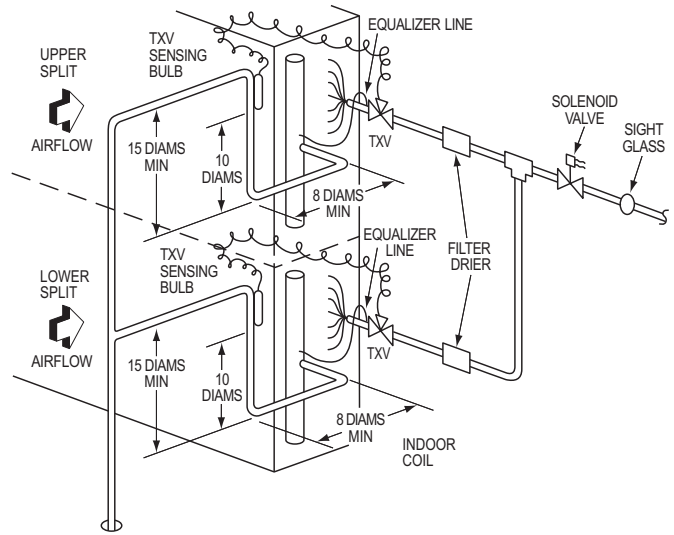

Dual Circuit Coil Piping Configuration - RU*12-16
For single compressor condensing units

LEGEND:

TXV – Thermostatic Expansion Valve

NOTE: Component location arrangement shown for field installation of sight glasses, solenoid valves, filter driers, and TXV sensing bulbs. The TXVs and equalizer lines are factory installed.

Fig. 8 - Face-Split Coil Suction and Liquid Line Piping (Typical)

C10687

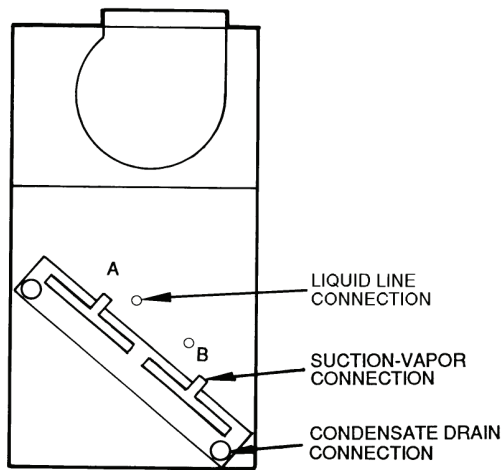

FIRST ON/LAST OFF = B
VERTICAL INSTALLATION

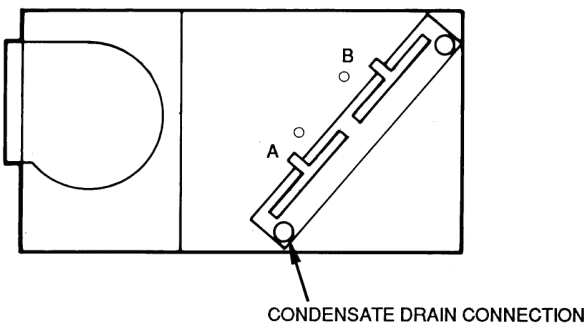

FIRST ON/LAST OFF = A
HORIZONTAL INSTALLATION

C10688

Fig. 9 - Typical Evaporator Coil Connections (40RU)

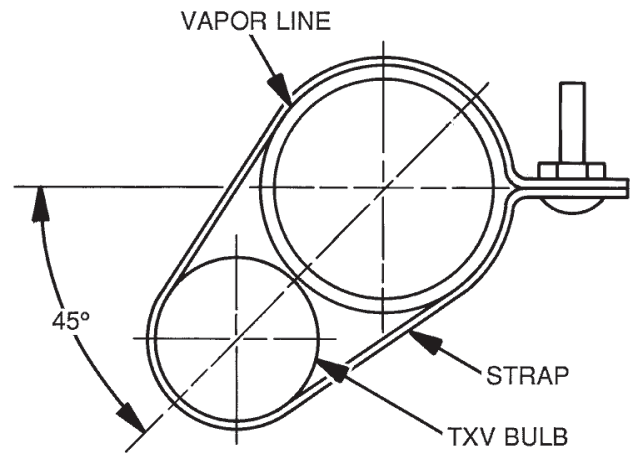

LEGEND

TXV — Thermostatic Expansion Valve

NOTE: The 8 o'clock position is shown above.

C10689

Fig. 10 - TXV Sensing Bulb Location

Table 2 – Factory-Installed Nozzle and Distributor Data

UNIT	COIL TYPE STD	TXV Qty...Part No.	DISTRIBUTOR Qty...Part No.	FEEDER TUBES PER DISTRIBUTOR† Qty...Size (in.)	NOZZLE Qty...Part No.
40RUA*07	4 Row	1...BBIZE-5-GA	1...1135	12... ¹ / ₄	1...G4
40RUQ*07	3 Row	1...BBIZE-5-GA	1...1136	15... ¹ / ₄	1...G5
40RUQ*07T	4 Row	1...BBIZE-8-GA	1...1113	12... ³ / ₁₆	1...G5
40RUA*08	4 Row	1...BBIZE-6-GA	1...1136	15... ¹ / ₄	1...G5
40RUQ*08	4 Row	1...BBIZE-8-GA	1...1113	12... ³ / ₁₆	1...G5
40RUA*12	4 Row	2...BBIZE-4-GA	2...1135	9... ¹ / ₄	2...G3
40RUQ*12	4 Row	2...BBIZE-5-GA	2...1113	9... ³ / ₁₆	2...G3
40RUA*14	4 Row	2...BBIZE-5-GA	2...1113	12... ³ / ₁₆	2...G3
40RUA*16	4 Row	2...BBIZE-6-GA	2...1136	16... ³ / ₁₆	2...G4
40RUQ*16	4 Row	2...BBIZE-8-GA	2...1113	10... ³ / ₁₆	2...G5

† Feeder tube size is ¹/₄ in. (6.35 mm).

NOTE: Hot gas bypass applications require field-supplied auxiliary side connector.

Table 3 – Fitting Requirements

UNIT	ACCESS HOLE NO.‡	CONNECTION TYPE	CIRCUIT	FITTINGS REQUIRED† (in.)
40RUA*07 40RUQ*07	1	Suction	—	1 ¹ / ₈ Street Elbow 1 ¹ / ₈ Nipple, 10 ⁵ / ₈ L 1 ¹ / ₈ Long Radius Elbow
	3	Liquid	—	5 ⁸ / ₈ Street Elbow 5 ⁸ / ₈ Nipple, 8 ⁵ / ₈ L 5 ⁸ / ₈ Long Radius Elbow
40RUA*08 40RUQ*08	1	Suction	—	1 ¹ / ₈ Street Elbow 1 ¹ / ₈ Nipple, 8 ⁵ / ₈ L 1 ¹ / ₈ Long Radius Elbow
	3	Liquid	—	5 ⁸ / ₈ Street Elbow 5 ⁸ / ₈ Nipple, 8 ⁵ / ₈ L 5 ⁸ / ₈ Long Radius Elbow
40RUS*08 40RUS*10 40RUS*12	4	Return	—	1 ³ / ₈ Nipple, 4 ³ / ₈ L 1 ³ / ₈ Long Radius Elbow 1 ³ / ₈ Nipple, 7 ³ / ₈ L 1 ³ / ₈ Long Radius Elbow
	5	Supply	—	1 ³ / ₈ Nipple, 6 ⁵ / ₈ L 1 ³ / ₈ Long Radius Elbow
40RUA*12	1	Suction	Lower	(2) 1 ¹ / ₈ Street Elbow
	2	Liquid	Lower	5 ⁸ / ₈ Street Elbow 5 ⁸ / ₈ Nipple, 8 ¹ / ₂ L 5 ⁸ / ₈ Long Radius Elbow
	3	Liquid	Upper	5 ⁸ / ₈ Street Elbow 5 ⁸ / ₈ Nipple, 13 ¹ / ₂ L 5 ⁸ / ₈ Long Radius Elbow
	4	Suction	Upper	1 ¹ / ₈ Nipple, 5 ³ / ₄ L 1 ¹ / ₈ Long Radius Elbow 1 ¹ / ₈ Nipple, 12 L 1 ¹ / ₈ Long Radius Elbow

‡ See Fig. 7 for access hole location by number.

† Fittings are listed in order from header or tee stub connection out to access hole in corner support post.

40RU

Table 3 - Fitting Requirement (cont)

40RU

UNIT	ACCESS HOLE NO.‡	CONNECTION TYPE	CIRCUIT	FITTINGS REQUIRED† (in.)
40RUQ*12	1	Suction	Lower	(2) 1 1/8 Street Elbow
	2	Liquid	Lower	5/8 Street Elbow
				5/8 Nipple, 5 1/2 L 5/8 Long Radius Elbow
	3	Liquid	Upper	5/8 Street Elbow 5/8 Nipple, 10 1/2 L 5/8 Long Radius Elbow
4	Suction	Upper	1 1/8 Nipple, 5 5/8 L 1 1/8 Long Radius Elbow 1 1/8 Nipple, 12 L 1 1/8 Long Radius Elbow	
40RUA*14	1	Suction	Lower	1 1/8 Street Elbow 1 1/8 Nipple, 7 5/8 L 1 1/8 Long Radius Elbow
	2	Liquid	Lower	5/8 Street Elbow 5/8 Nipple, 1 7/16 L 5/8 Long Radius Elbow
				5/8 Street Elbow 5/8 Nipple, 11 1/2 L 5/8 Long Radius Elbow
	4	Suction	Upper	1 1/8 Nipple, 5 5/8 L 1 1/8 Long Radius Elbow 1 1/8 Nipple, 13 L 1 1/8 Long Radius Elbow
40RUA*16	1	Suction	Lower	1 1/8 Street Elbow 1 1/8 Nipple, 7 3/4 L 1 1/8 Long Radius Elbow
	2	Liquid	Lower	5/8 Street Elbow 5/8 Nipple, 1 3/8 L 5/8 Long Radius Elbow
				5/8 Street Elbow 5/8 Nipple, 11 1/2 L 5/8 Long Radius Elbow
	4	Suction	Upper	1 1/8 Nipple, 5 5/8 L 1 1/8 Long Radius Elbow 1 1/8 Nipple, 13 L 1 1/8 Long Radius Elbow
40RUQ*16	3	Suction	Lower	1 1/8 Nipple, 3 L 1 1/8 Long Radius Elbow
	5	Suction	Lower	5/8 Nipple, 2 7/8 L 5/8 45° Elbow 5/8 Nipple, 1 5/8 L 5/8 Long Radius Elbow
				5/8 Nipple, 2 7/8 L 5/8 45° Elbow 5/8 Nipple, 4 1/4 L 5/8 Long Radius Elbow
	7	Suction	Upper	1 1/8 Nipple, 5 L 1 1/8 45° Elbow 1 1/8 Nipple, 8 3/4 L 1 1/8 Long Radius Elbow

‡ See Fig. 7 for access hole location by number.

† Fittings are listed in order from header or tee stub connection out to access hole in corner support post.

Table 3 - Fitting Requirement (cont)

UNIT	ACCESS HOLE NO.‡	CONNECTION TYPE	CIRCUIT	FITTINGS REQUIRED† (in.)
40RUS*14 40RUS*16	4	Supply	Lower	1 ³ / ₈ Long Radius Elbow 1 ³ / ₈ Nipple, 3 ³ / ₄ L 1 ³ / ₈ Long Radius Elbow
	5	Return	Lower	1 ³ / ₈ Long Radius Elbow 1 ³ / ₈ Nipple, 3 ³ / ₈ L 1 ³ / ₈ Long Radius Elbow
	6	Return	Upper	1 ³ / ₈ Long Radius Elbow 1 ³ / ₈ Nipple, 7 L 1 ³ / ₈ Long Radius Elbow
	7	Supply	Upper	1 ³ / ₈ Long Radius Elbow 1 ³ / ₈ Nipple, 11 ³ / ₄ L 1 ³ / ₈ Long Radius Elbow

‡ See Fig. 7 for access hole location by number.

† Fittings are listed in order from header or tee stub connection out to access hole in corner support post.

Chilled Water Piping - See Tables 1E and 1F for chilled water connection sizes. For ease in brazing, it is recommended that all internal solder joints be made before unit is placed in final position.

Knockouts are provided in the unit corner posts for 40RUS refrigerant piping. Additional field-fabricated access holes are required for 40RUS chilled water piping. See Fig. 7, which lists recommended knockouts and access holes to use for each 40RUS unit size.

To size, design, and install chilled water piping, consult the Carrier System Design manual. See Fig. 11 for an example of a typical installation. Recommended fittings are listed in Table 3.

To access 40RUS coil vents and drains, remove the unit side panel over the coil header. Vent and drain plugs are on the top and bottom of header, respectively. See the Service section for information on preventing coil freeze-up during winter.

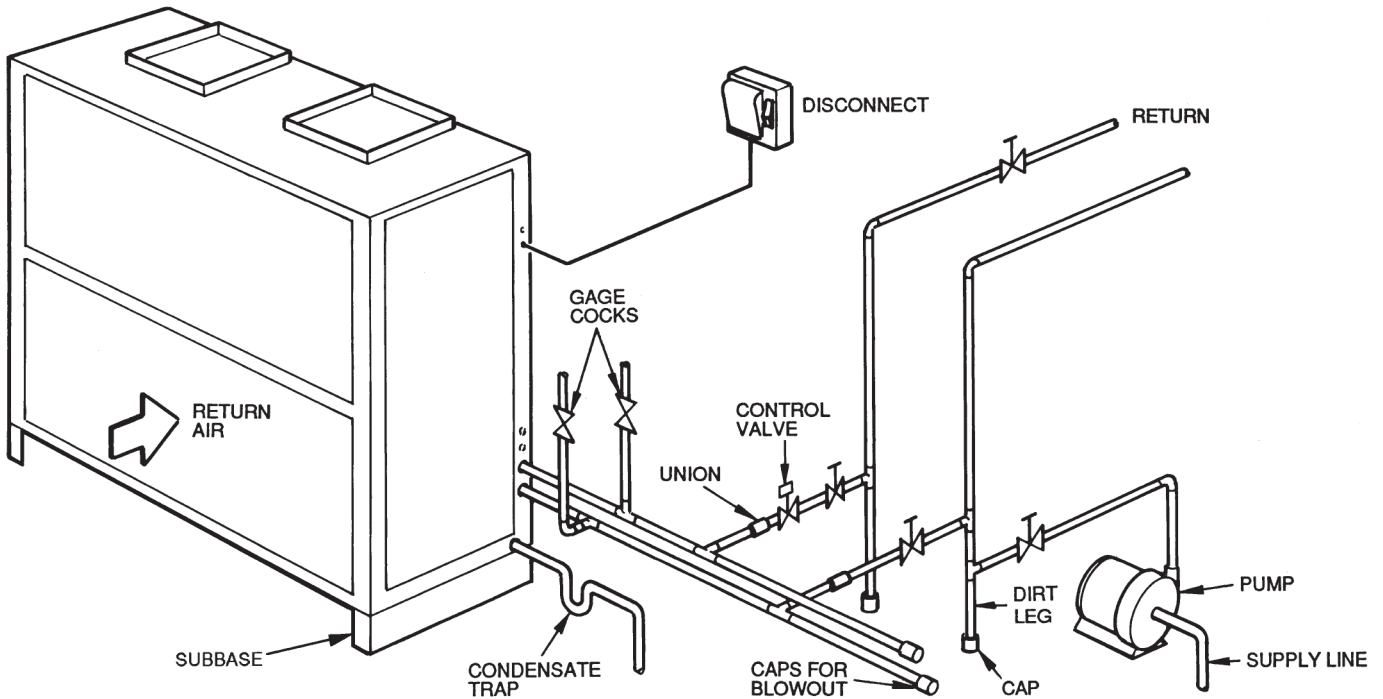

Fig. 11 - Typical 40RUS Chilled Water Piping

C10690

40RU

Condensate Drain — Install a trapped condensate drain line to unit connection as shown in Fig. 12. The unit drain connection is a PVC stub. See Fig. 13. Some areas may require an adapter to connect to either galvanized steel or copper pipe. For these applications, install a field-supplied threaded PVC adapter.

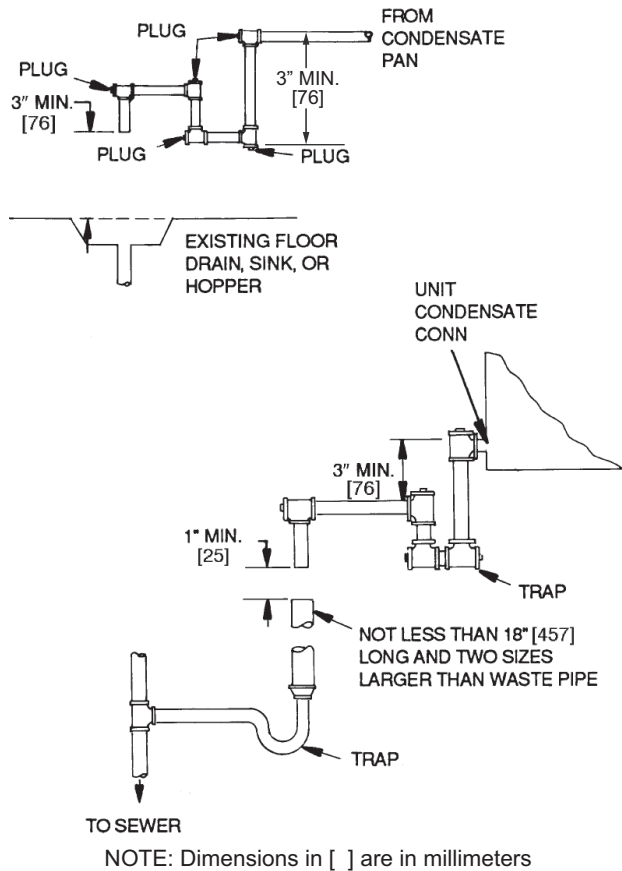

Fig. 12 - Condensate Drains

NOTE: A trap must be installed in the condensate drain line to ensure that the static pressure of fans is balanced with the water column in the drain line and that condensate can drain completely from pan. Without a trap, air can be drawn up drain line until water level in condensate pan becomes equal to static pressure created by fans, preventing complete drainage. Conditions will worsen as filters become dirty.

Install clean-out plugs in trap. Pitch drain line downward to an open floor drain or sump. Provide service clearance around drain line to permit removal of unit panels. Observe all local sanitary codes.

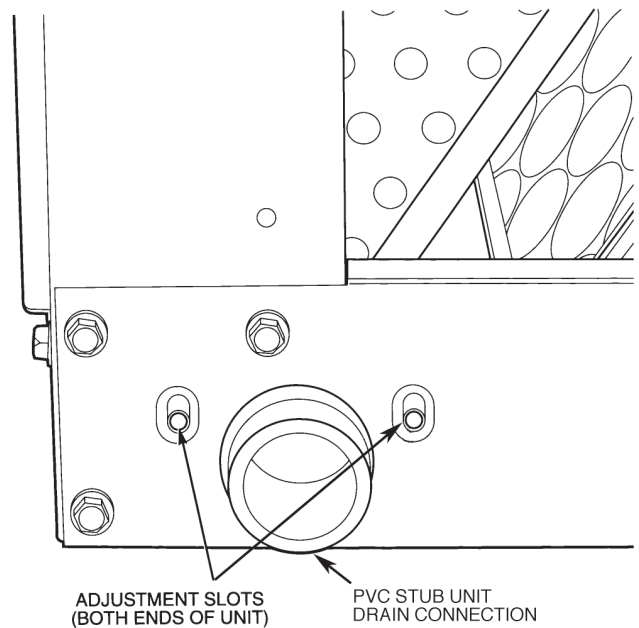

Fig. 13 - Drain Pan Slope Adjustment

As shipped, the unit's condensate drain pan is NOT sloped towards the drain connection. The pan slope must be changed to pitch towards the side of the unit with the drain connection. See Fig. 13. Loosen the 2 screws next to the drain outlet at both ends of the unit, push drain pan down in the slots near the drain connection, and up in the slots on the opposite end. Re-tighten screws. The pan should have a pitch of at least $\frac{1}{4}$ -in. over its length toward the drain connection.

Fan Motor and Drives - Motor and drive packages are factory installed in all units. The motor and drive packages consist of the following items:

- 1 — fan motor
- 1 — adjustable motor pulley
- 1 — fan pulley
- 1 — fan belt
(40RUA*07-12, 40RUQ*07-12, 40RUS*08-12 units)
- 2 — matched fan belts
(40RUA*14-16, 40RUQ*16, 40RUS*14-16 units)

For instructions on changing fan rotation, changing drive speeds and adjusting drives, see Pulley and Drive Adjustment in the Service section.

Power Supply and Wiring - Check the unit data plate to ensure that available power supply matches electrical characteristics of the unit. Provide a disconnect switch with an integrated lock-out feature of size required to provide adequate fan motor starting current. See Tables 4-8 for unit electrical data.

⚠ WARNING

ELECTRICAL SHOCK HAZARD

Failure to follow this warning could result in personal injury or death.

Do not use gas piping as an electrical ground. Unit cabinet must have an uninterrupted, unbroken electrical ground to minimize the possibility of personal injury if an electrical fault should occur. This ground may consist of electrical wire connected to unit ground lug in control compartment, or conduit approved for electrical ground when installed in accordance with NEC (National Electrical Code); ANSI/NFPA 70, latest edition (in Canada, Canadian Electrical Code CSA [Canadian Standards Association] C22.1), and local electrical codes.

⚠ WARNING

FIRE HAZARD

Failure to follow this warning could result in intermittent operation or performance satisfaction.

Do not connect aluminum wire between disconnect switch and fan coil unit. Use only copper wire.

(See Fig. 14)

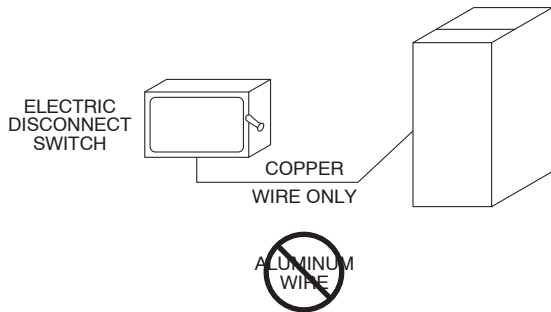

Fig. 14 - Disconnect Switch and Unit

Install disconnect switch and power wiring in accordance with all applicable local codes. See Fig. 14-16 and the unit label diagram. For units with motor sizes less than 5 Hp (3.7 kW), connect power wiring to unit with no. 10 ring terminal. For units with motor sizes of 5 Hp (3.7 kW) or more, connect power wiring with 1/4-in. ring terminal.

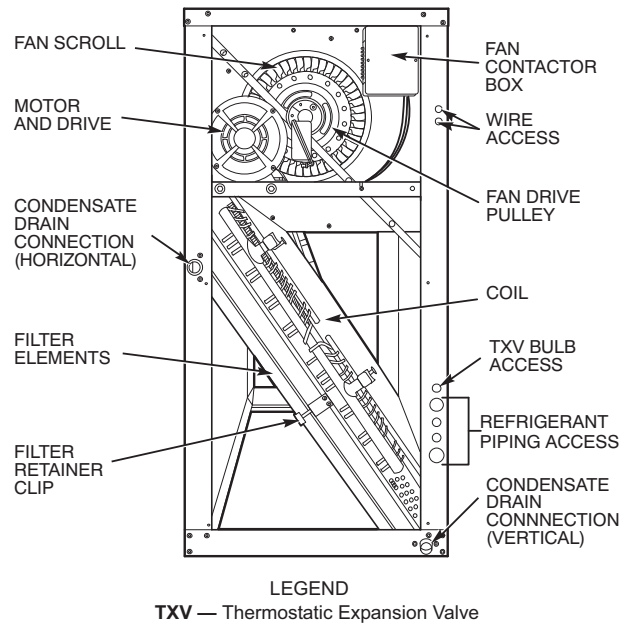

Fig. 15 - Wiring and Service Access (Side Panel Removed)

The 40RU size 07-16 units that have motors wired for 460-v, 3-ph, 60 Hz operation can be field-converted to 208/230-v, 3-ph, 60 Hz operation. Rewire the motor according to the diagram plate on the motor. After reconfiguring the motor, mark the motor specifying 208-v or 230-v operation replacing the 460-v sticker information on the units' corner post.

Fan motors are factory-installed on all units. Indoor-fan contactors are located in the fan contactor box behind the side access panel (see Fig. 15 and 16). Wire the thermostat to the 24-v control circuit terminal block located in the side of the fan contactor control box, according to Fig. 17 or the unit label diagram. If the air handler is part of a split system, complete the wiring from the condensing unit to the thermostat shown in Fig. 17.

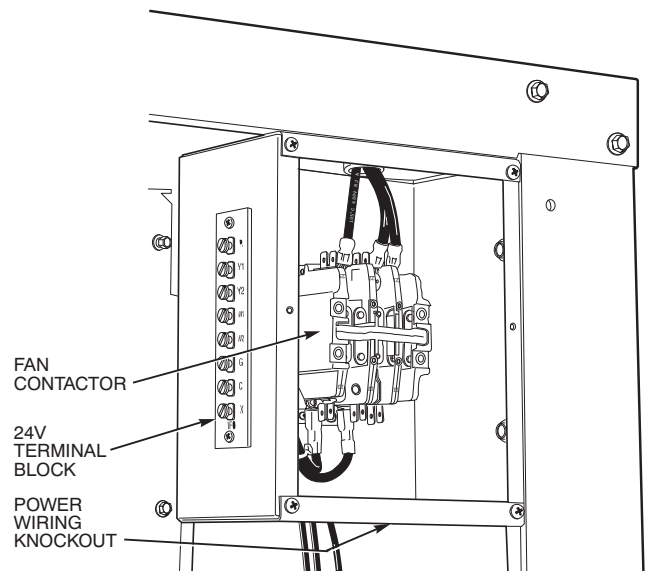

Fig. 16 - Fan Contactor Box and Terminal Block (Cover Removed) (Typical)

40RU

C10693

C10694

Table 4 – Electrical Data, Standard Motors - Single Speed

UNIT	V-PH-Hz†	VOLTAGE LIMITS	FAN MOTOR		POWER SUPPLY	
			Hp (kW)	FLA	Minimum Circuit Amps	MAX FUSE or HACR BRKR
40RUA*07 40RUQ*07	208/230-1-60	187-253	1.3 (0.97)	6.6	9.0	15
	208/230-3-60	187-253	2.4 (1.79)	5.2	7.0	15
	460-3-60	414-506	2.4 (1.79)	2.6	4.0	15
	575-3-60	518-632	1.0 (0.75)	1.4	2.0	15
40RUA*08 40RUS*08 40RUQ*08	208/230-1-60	187-253	2.4 (1.79)	11.0	13.8	20
	208/230-3-60	187-253	2.4 (1.79)	5.2	7.0	15
	460-3-60	414-506	2.4 (1.79)	2.6	4.0	15
	575-3-60	518-632	2.0 (1.49)	2.4	3.0	15
40RUS*10	208/230-1-60	187-253	2.4 (1.79)	11.0	13.8	20
	208/230-3-60	187-253	2.4 (1.79)	5.2	7.0	15
	460-3-60	414-506	2.4 (1.79)	2.6	4.0	15
	575-3-60	518-632	2.0 (1.49)	2.3	3.0	15
40RUA*12 40RUS*12 40RUQ*12	208/230-3-60	187-253	2.4 (1.79)	5.2	7.0	15
	460-3-60	414-506	2.4 (1.79)	2.6	4.0	15
	575-3-60	518-632	2.0 (1.49)	2.4	3.0	15
40RUA*14 40RUS*14	208/230-3-60	187-253	2.9 (2.16)	7.5	10.0	15
	460-3-60	414-506	2.9 (2.16)	3.4	5.0	15
	575-3-60	518-632	3.0 (2.24)	3.8	5.0	15
40RUA*16 40RUS*16 40RUQ*16	208/230-3-60	187-253	3.7 (2.76)	10.2	13.0	20
	460-3-60	414-506	3.7 (2.76)	4.8	6.0	15
	575-3-60	518-632	3.0 (2.24)	3.8	5.0	15

See Legend and Notes on page 22.

Table 5 – Electrical Data, Alternate Motors - Single Speed

UNIT	V-PH-Hz†	VOLTAGE LIMITS	FAN MOTOR		POWER SUPPLY	
			Hp (kW)	FLA	Minimum Circuit Amps	MAX FUSE or HACR BRKR
40RUA*07 40RUQ*07	208/230-1-60	187-253	2.4 (1.79)	11.0	13.8	20
	208/230-3-60	187-253	2.9 (2.16)	7.5	10.0	15
	460-36-0	414-506	2.9 (2.16)	3.4	5.0	15
	575-3-60	518-632	2.0 (1.49)	2.4	3.0	15
40RUA*08 40RUS*08 40RUQ*08	208/230-1-60	187-253	2.4 (1.79)	11.0	13.8	15
	208/230-3-60	187-253	2.9 (2.16)	7.5	10.0	15
	460-3-60	414-506	2.9 (2.16)	3.4	5.0	15
	575-3-60	518-632	3.0 (2.24)	3.8	5.0	15
40RUS*10	208/230-1-60	187-253	2.4 (1.79)	11.0	13.8	20
	208/230-3-60	187-253	2.9 (2.16)	7.5	10.0	15
	460-3-60	414-506	2.9 (2.16)	3.4	5.0	15
	575-3-60	518-632	3.0 (2.24)	3.8	5.0	15
40RUA*12 40RUS*12 40RUQ*12	208/230-3-60	187-253	3.7 (2.76)	10.2	13.0	20
	460-3-60	414-506	3.7 (2.76)	4.8	6.0	15
	575-3-60	518-632	3.0 (2.24)	3.8	5.0	15
40RUA*14 40RUS*14	208/230-3-60	187-253	3.7 (2.76)	10.2	13.0	20
	460-3-60	414-506	3.7 (2.76)	4.8	6.0	15
	575-3-60	518-632	5.0 (3.73)	8.0	10.0	15
40RUA*16 40RUS*16 40RUQ*16	208/230-3-60	187-253	5.0 (3.73)	18.0	23.0	40
	460-3-60	414-506	5.0 (3.73)	9.1	12.0	20
	575-3-60	518-632	5.0 (3.73)	8.0	10.0	15

See Legend and Notes on page 22.

40RU

Table 6 – Electrical Data, Standard Motors - Two Speed

UNIT	V-PH-Hz†	VOLTAGE LIMITS	FAN MOTOR		POWER SUPPLY	
			Hp (kW)	FLA	Minimum Circuit Amps	MAX FUSE or HACR BRKR
40RUA*07 40RUQ*07	208/230-3-60	187-253	2.4 (1.79)	7.1	9.0	15
	460-3-60	414-506	2.4 (1.79)	3.8	5.0	15
	575-3-60	518-632	2.4 (1.79)	3.5	5.0	15
40RUA*08 40RUS*08 40RUQ*08	208/230-3-60	187-253	2.4 (1.79)	7.1	9.0	15
	460-3-60	414-506	2.4 (1.79)	3.8	5.0	15
	575-3-60	518-632	2.4 (1.79)	3.5	5.0	15
40RUS*10	208/230-3-60	187-253	2.4 (1.79)	7.1	9.0	15
	460-3-60	414-506	2.4 (1.79)	3.8	5.0	15
	575-3-60	518-632	2.4 (1.79)	3.5	5.0	15
40RUA*12 40RUS*12	208/230-3-60	187-253	2.4 (1.79)	7.1	9.0	15
	460-3-60	414-506	2.4 (1.79)	3.8	5.0	15
	575-3-60	518-632	2.4 (1.79)	3.5	5.0	15
40RUQ*12 Units Produced On or Prior to 02/28/2016	208/230-3-60	187-253	2.4 (1.79)	7.1	9.0	15
	460-3-60	414-506	2.4 (1.79)	3.8	5.0	15
	575-3-60	518-632	2.4 (1.79)	3.5	5.0	15
40RUQ*12 Units Produced On or After 02/29/2016	208/230-3-60	187-253	1.7 (1.27)	5.8	8.0	15
	460-3-60	414-506	1.7 (1.27)	2.9	4.0	15
	575-3-60	518-632	1.7 (1.27)	2.8	4.0	15
40RUA*14 40RUS*14	208/230-3-60	187-253	2.9 (2.16)	8.6	11.0	15
	460-3-60	414-506	2.9 (2.16)	3.8	5.0	15
	575-3-60	518-632	3.7 (2.76)	4.5	6.0	15
40RUA*16 40RUS*16 40RUQ*16	208/230-3-60	187-253	3.7 (2.76)	10.8	14.0	20
	460-3-60	414-506	3.7 (2.76)	4.9	7.0	15
	575-3-60	518-632	3.7 (2.76)	4.5	6.0	15

See Legend and Notes on page 22.

40RU

Table 7 – Electrical Data, Alternate Motors - Two Speed

UNIT	V-PH-Hz†	VOLTAGE LIMITS	FAN MOTOR		POWER SUPPLY	
			Hp (kW)	FLA	Minimum Circuit Amps	MAX FUSE or HACR BRKR
40RUA*07 40RUQ*07	208/230-3-60	187-253	3.7 (2.76)	10.8	14.0	20
	460-36-0	414-506	3.7 (2.76)	4.9	7.0	15
	575-3-60	518-632	3.7 (2.76)	4.5	6.0	15
40RUA*08 40RUS*08 40RUQ*08	208/230-3-60	187-253	3.7 (2.76)	10.8	14.0	20
	460-3-60	414-506	3.7 (2.76)	4.9	7.0	15
	575-3-60	518-632	3.7 (2.76)	4.5	6.0	15
40RUS*10	208/230-3-60	187-253	3.7 (2.76)	10.8	14.0	20
	460-3-60	414-506	3.7 (2.76)	4.9	7.0	15
	575-3-60	518-632	3.7 (2.76)	4.5	6.0	15
40RUA*12 40RUS*12	208/230-3-60	187-253	3.7 (2.76)	10.8	14.0	20
	460-3-60	414-506	3.7 (2.76)	4.9	7.0	15
	575-3-60	518-632	3.7 (2.76)	4.5	6.0	15
40RUQ*12 Units Produced On or Prior to 02/28/2016	208/230-3-60	187-253	3.7 (2.76)	10.8	14.0	20
	460-3-60	414-506	3.7 (2.76)	4.9	7.0	15
	575-3-60	518-632	3.7 (2.76)	4.5	6.0	15
40RUQ*12 Units Produced On or After 02/29/2016	208/230-3-60	187-253	3.7 (2.76)	10.6	14.0	20
	460-3-60	414-506	3.7 (2.76)	5.3	7.0	15
	575-3-60	518-632	3.7 (2.76)	4.5	6.0	15
40RUA*14 40RUS*14	208/230-3-60	187-253	3.7 (2.76)	10.8	14.0	20
	460-3-60	414-506	3.7 (2.76)	4.9	7.0	15
	575-3-60	518-632	5.0 (3.73)	8.0	10.0	15
40RUA*16 40RUS*16 40RUQ*16	208/230-3-60	187-253	5.0 (3.73)	18.0	23.0	40
	460-3-60	414-506	5.0 (3.73)	9.1	12.0	20
	575-3-60	518-632	5.0 (3.73)	8.0	10.0	15

See Legend and Notes on page 22.

Table 8 – Fan Contactor Coil Data

UNIT 40RU*	VOLTAGE (vac)	MAXIMUM HOLDING VA
07, 08, 12, 14, 16	24	10

Legend and Notes for Tables 4 – 7

LEGEND:

FLA – Full Load Amps

MOCOP – Maximum Overcurrent Protection

† Motors are designed for satisfactory operation within 10% of normal voltage shown. Voltages should not exceed the limits shown in the Voltage Limits column.

NOTES:

1. Minimum circuit amps (MCA) and MOCOP values are calculated in accordance with The NEC, Article 440.
2. Motor FLA values are established in accordance with Underwriters' Laboratories (UL), Standard 1995.
3. **Unbalanced 3-Phase Supply Voltage**
Never operate a motor where a phase imbalance in supply voltage is greater than 2%. Use the formula in the example (see column to the right) to determine the percentage of voltage imbalance.
4. **Installation with Accessory Electric Heaters**
Size the Field Power Wiring between the heater TB1 and the 40RU indoor fan motor per NEC Article 430-28 (1) or (2) (depends on length of conduit between heater enclosure and 40RU power entry location). Install wires in field-installed conduit.

Example: Supply voltage is 230-3-60

$$\% \text{ Voltage Imbalance} = 100 \times \frac{\text{max voltage deviation from average voltage}}{\text{average voltage}}$$



AB = 393 v
BC = 403 v
AC = 396 v

$$\text{Average Voltage} = \frac{(393 + 403 + 396)}{3} = \frac{1192}{3} = 397$$

Determine maximum deviation from average voltage.

(AB) 397 – 393 = 4 v

(BC) 403 – 397 = 6 v

(AC) 397 – 396 = 1 v

Maximum deviation is 4 v.

Determine percent of voltage imbalance.

$$\% \text{ Voltage Imbalance} = 100 \times \frac{6}{397} = 1.5\%$$

This amount of phase imbalance is satisfactory as it is below the maximum allowable 2%.

IMPORTANT: If the supply voltage phase imbalance is more than 2%, contact your local electric utility company immediately.

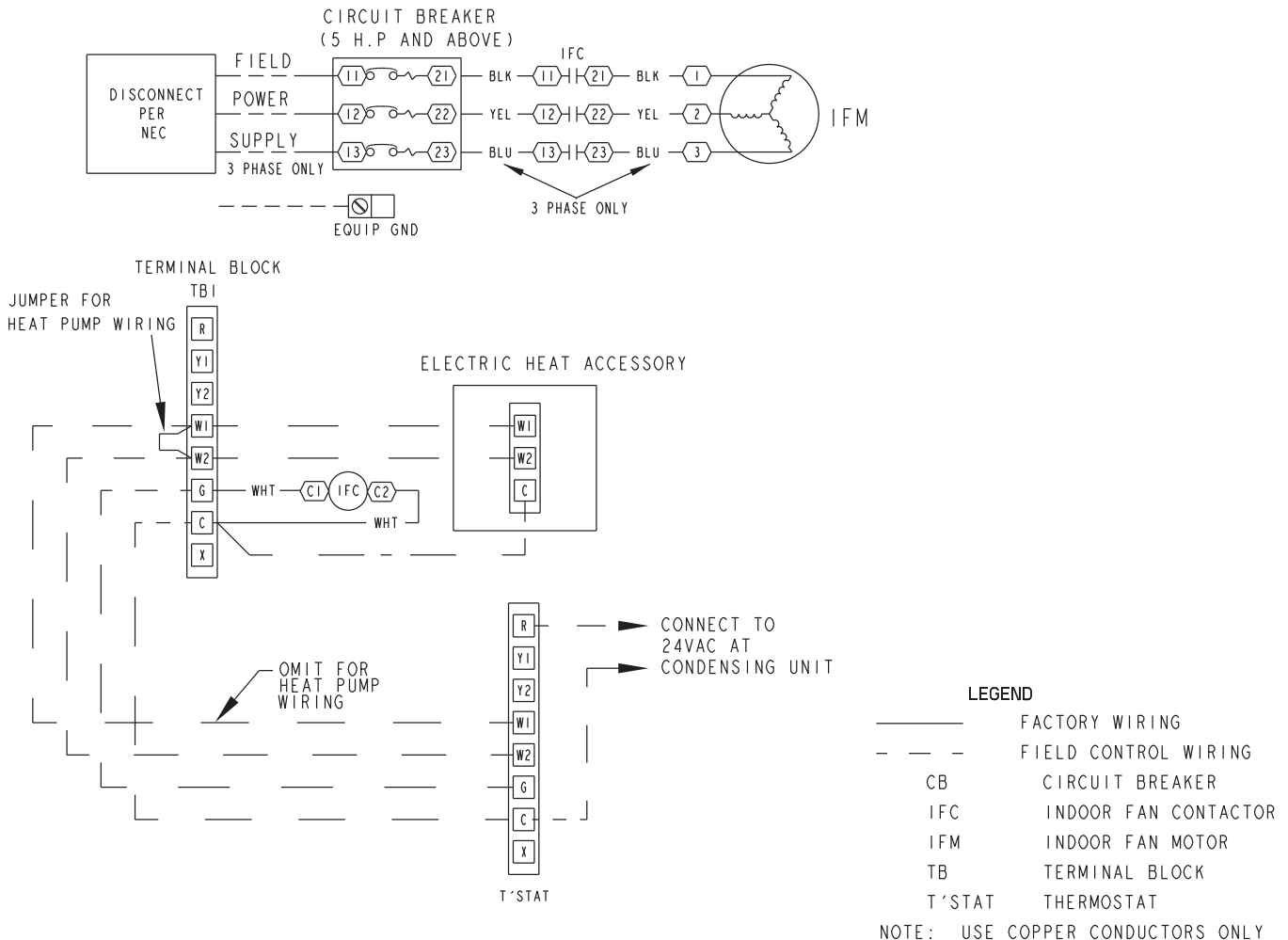

Fig. 17 - Unit Wiring

Connecting Ductwork - Refer to the Carrier System Design Manual for the recommended design and layout of ductwork. Fig. 18 shows recommended duct connection to units with 2 fans.

⚠ CAUTION

UNIT OPERATION HAZARD

Failure to follow this caution could cause equipment damage.

Do not operate unit without ductwork or discharge plenum unless fan speed has been adjusted for external static pressure of zero in. wg. Failure to do so may result in motor overload.

DISCHARGE CONNECTIONS — Duct flanges are factory-supplied; they are shipped inside the unit attached to the hairpin end of the coil tube sheet for field installation. Using the existing screws, install the duct flanges on the unit's fan deck. Each fan discharge requires 2 flanges; each flange must be bent in the middle to conform to the discharge opening. See Fig. 19. After flanges are installed, connect them to the supply duct using a canvas connection to prevent vibration. It is important that this connection be properly fabricated to prevent high air friction losses and air noise.

RETURN CONNECTIONS — When using return-air ductwork, route return-air duct to the unit's return air inlet near the filter rack, using a canvas connection to prevent transmission of unit vibration. If the duct blocks off the unit's access panel, provide a slip joint in the ductwork to permit removal for servicing.

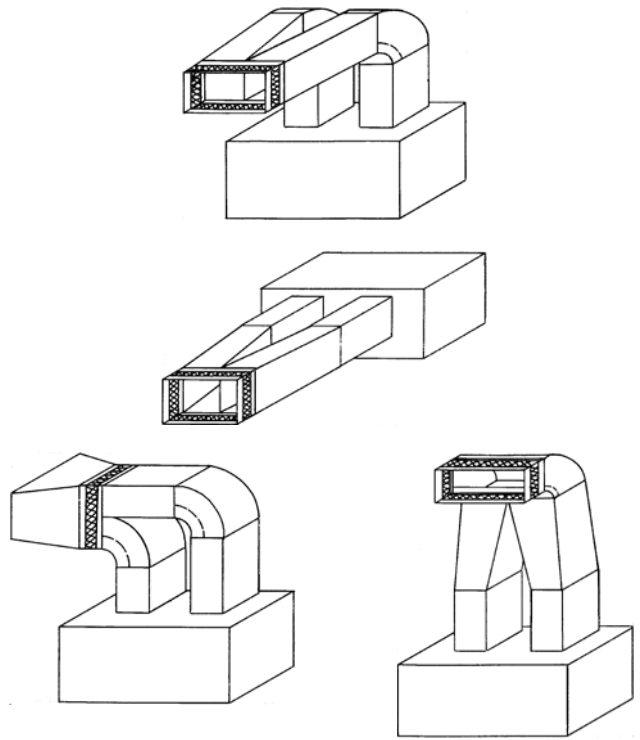

Fig. 18 - Typical Fan Discharge Connections for Multiple Fan Units

C10696

OUTDOOR-AIR INLET CONNECTIONS — Connect outdoor-air inlet to field-installed accessory economizer. Refer to Economizer Installation Instructions.

Return-Air Filters - Type and size of filters are shown in Tables 1A - 1F and are factory-supplied and factory-installed. In all units with 2 fans, a filter replacement tool (hook) is shipped inside the unit for field use when replacing filters. See the Service section for instructions on filter element replacement.

40RU

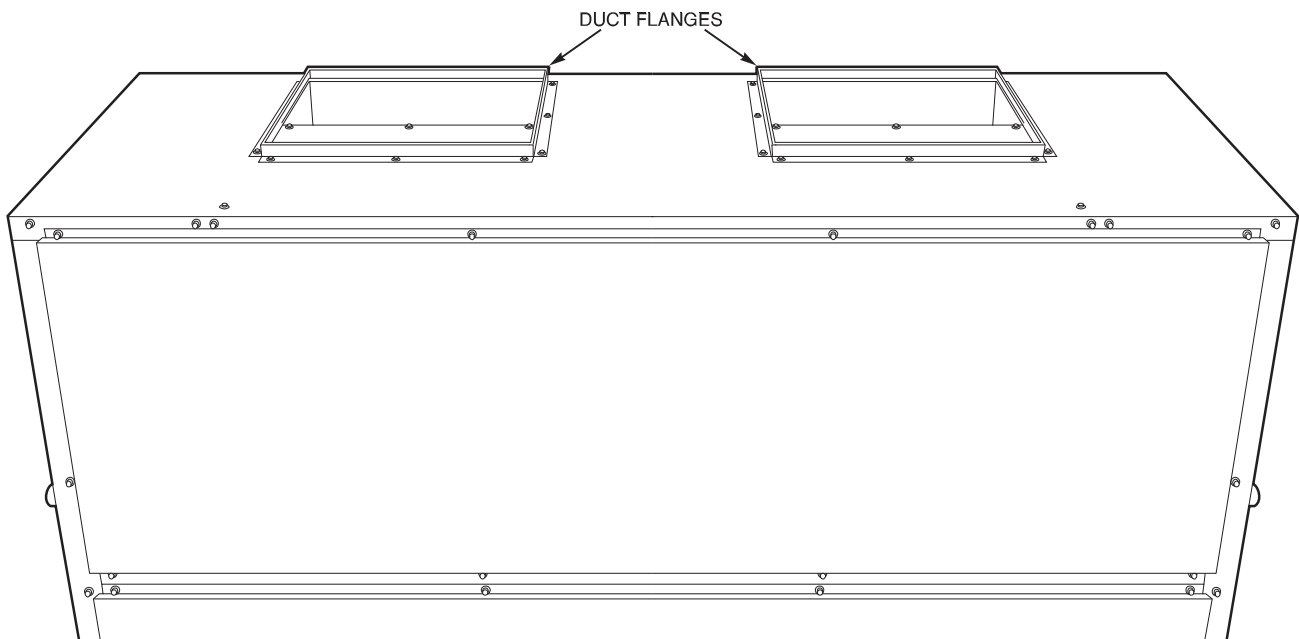

Fig. 19 - Duct Flange Installation

C10697

START-UP

Before starting unit, check the following and correct as necessary:

- Is unit solidly supported?
- Is fan adjusted for speed and pulley alignment?
- Are pulleys, motor, and bearings securely mounted?
- Are there any loose parts that will rattle or vibrate?
- Is condensate drain pan pitched for correct drainage?
- Are coil baffle plates tight against coil to prevent air bypass?
- Are all panels securely fastened?
- Are all electrical connections correct and tight?

40RUA and 40RUQ ONLY —

- Is TXV bulb located on suction tube per Fig. 20?
- Is the capillary tube to the bulb free of kinks and not subject to pinching?
- Is the bulb well secured to the suction tube with strap?

Also refer to condensing unit or outdoor heat pump section instructions before starting a split system. A split system start-up checklist is provided at the end of these instructions.

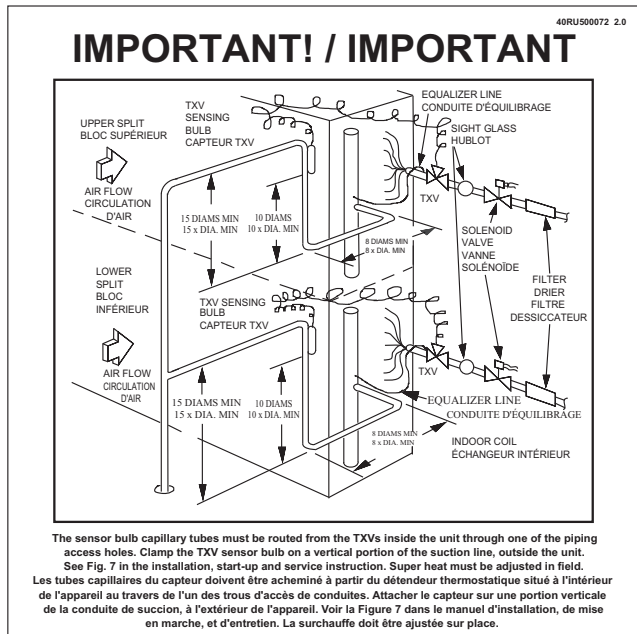

Fig. 20 - Label, TXV Bulb Location

Adjusting TXV for Superheat (40RUA and RUQ only) —

The unit-mounted thermostatic expansion valve(s) is/are factory set to provided superheat at the bulb location in 10°F to 15°F (5.5°C to 8.3°C) range. Actual system load conditions may require adjustment of the factory setting. To adjust the TXV superheat setting:

1. Remove the seal cap from the bottom of the TXV body.

2. To increase superheat, turn the stem clockwise. To decrease the superheat, turn the stem counterclockwise. Do not turn the stem more than one full turn.
3. Wait until suction pressure and superheat stabilize. This may take more than 30 minutes.
4. Continue adjustment until superheat reaches 10°F to 15°F (5.5°C to 8.3°C).
5. Replace the seal cap; tighten.



Fig. 21 - Label, TXV Adjustment

SERVICE

Inspection and maintenance should be performed at regular intervals and should include the following:

- Complete cleaning of cabinet, fan wheel, cooling coil, condensate pan and drain, heating coils, and return-air grille (if present).
- Inspection of panels and sealing of unit against air leakage.
- Adjustment of fan motor, belt, bearings, and wheels.
- Cleaning or replacement of filters.
- Testing for cooling/heating system leaks.
- Checking of all electrical connections.

WARNING

ELECTRICAL SHOCK HAZARD

Failure to follow this warning could result in personal injury or death.

Before performing service or maintenance operations on unit, always turn off main power switch to unit and install lockout tag. Unit may have more than one power switch.

Most unit service can be performed by removing one or both of the unit's side panels. Coil cleaning or removal or insulation cleaning may require removal of a rear, top, or bottom panel, depending on the unit's orientation. When service is completed, replace unit panels.

Panels - Panels are fastened to unit frame with sheet metal screws. Fan and coil compartment must be sealed tightly after service to prevent air from bypassing the cooling coil.

Fan Motor Lubrication - Fan motor supplied with unit is permanently lubricated and requires no further lubrication.

Fan Shaft Bearings - Bearings on size 07-12 units are sealed, permanently lubricated bearings that require no further lubrication. Size 14-16 units have pillow-block bearings (Fig. 22) that must be lubricated with suitable bearing grease approximately every 3 months. See Table 9 for suitable lubricants.

Table 9 – Lubricant Data

MANUFACTURER	LUBRICANT
Mobil	Mobilplex EP No. 2
Sunoco	Prestige 42
Texaco	Multifak 2
Texaco	Regal AFB-2*

*Preferred lubricant, contains rust and oxidation inhibitors.

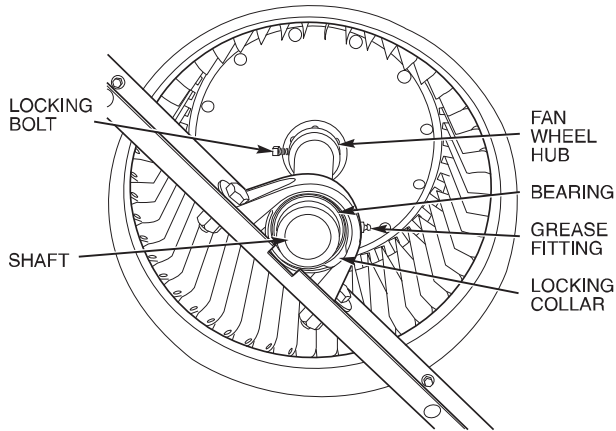

C10698

Fig. 22 - Fan Shaft, Bearings, and Fan Wheel (Typical)

Centering Fan Wheel - If fan and fan shaft assembly are not properly centered, blades may scrape against the blower side scroll plate or may create an objectionable whistling noise. It may be necessary to adjust individual fan wheels or move entire fan shaft. See the following two sections.

Fan Shaft Position Adjustment - Loosen setscrew or locking collar of each fan shaft bearing. Slide shaft into correct position and replace locking collar (Fig. 23). To replace locking collar, push collar up against inner face of bearing. Turn collar in direction of fan rotation until tight, and tighten setscrew. Tightening locking collar in direction of fan rotation results in further tightening of collar should setscrew work itself loose.

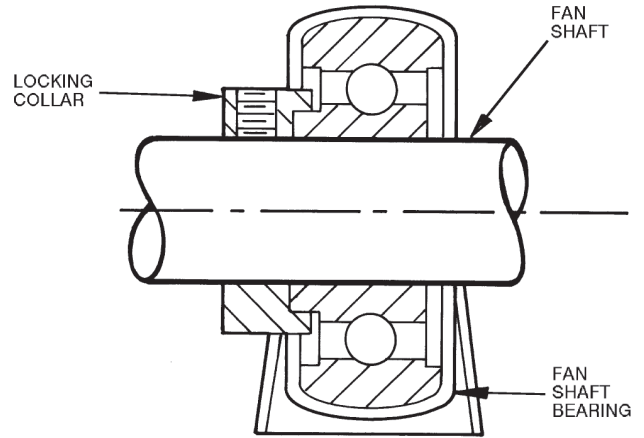

C10699

Fig. 23 - Fan Shaft Bearing

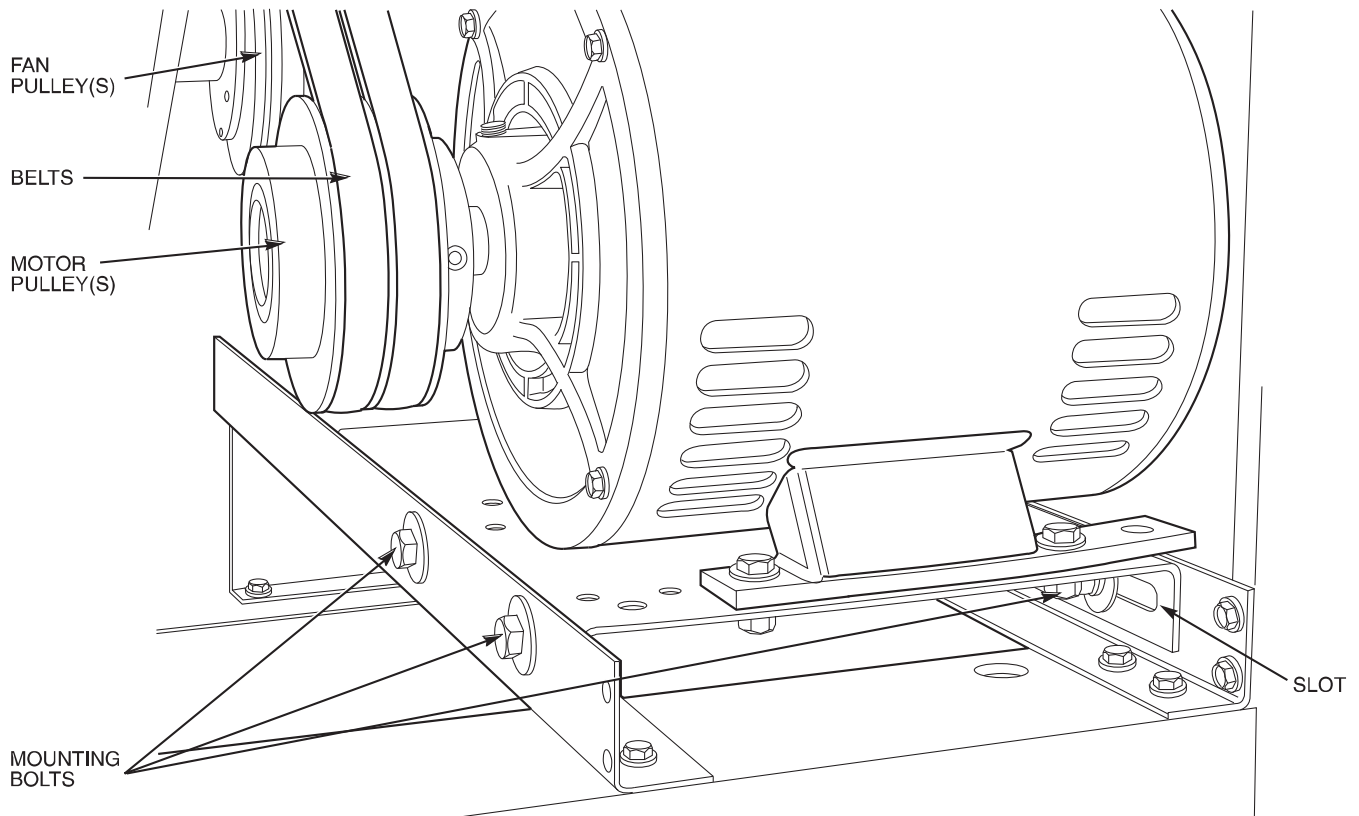

C10700

Fig. 24 - Fan Motor Mounting

40RU

Individual Fan Wheel Adjustment - Loosen the 2 locking bolts holding fan wheel hub to shaft. See Fig. 22. Position fan wheel in center of the fan housing and tighten locking bolts. Clearance between wheel and housing should be the same on both sides.

Fan Belts - Motor mounting plate and motor support angles are slotted to permit both vertical and horizontal adjustment. Adjust belt(s) for correct deflection by loosening motor plate mounting bolts, moving motor/plate assembly forward or back, and re tightening bolts. Press down on belt with one finger midway between fan and motor pulleys to check deflection. For units with motor sizes up to and including 3.7 Hp (2.76 kW), correct deflection is $\frac{3}{16}$ -in. (4.8 mm). For larger motor sizes, correct deflection is $\frac{1}{8}$ -in. (3.2 mm). See Fig. 24.

If complete belt replacement is required during servicing, loosen the motor plate mounting bolts (Fig. 24), move motor/plate assembly towards fan pulley, and pull belt(s) off pulleys. Reverse the procedure with new bolts and readjust deflection.

Fan Rotation - Correct fan rotation with respect to fan outlet is shown in Fig. 25.

To reverse the direction of rotation of a 3-phase fan motor, reverse any 2 of the power leads. Refer to the connection diagram on the inside of motor terminal box cover for proper reversing procedure of single-phase motor.

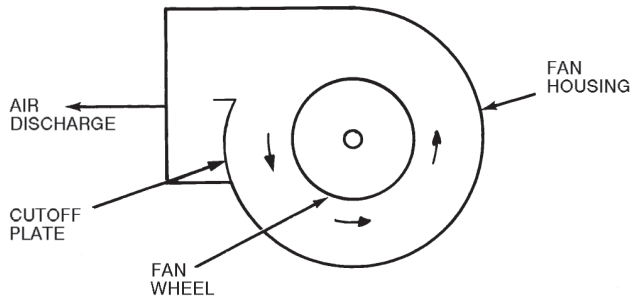

Fig. 25 - Fan Rotation

C10701

Fan Pulley Alignment - Align as follows:

1. Loosen setscrews on pulleys.
2. Align pulleys visually and tighten setscrews on fan pulley to lock it in place.
3. Use the methods shown in Fig. 26 to check proper pulley alignment.

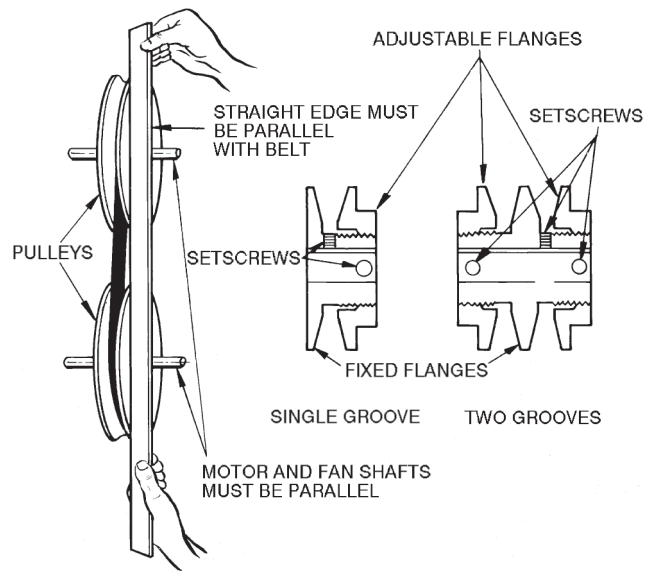

Fig. 26 - Fan Pulley Adjustments

C10702

4. If pulleys are not in correct alignment, loosen the motor holddown bolts and slide the motor axially until the pulleys are aligned.
5. Tighten motor holddown bolts.

Pulley and Drive Adjustment - To obtain desired fan speed, refer to the fan motor and drive data in Tables 8A-11D and adjust fan motor pulley as follows:

1. Remove belt from fan motor pulley after loosening motor from motor base.
2. Loosen setscrew in moveable flange of pulley. Screw moveable flange toward fixed flange to increase the fan speed and away from fixed flange to reduce speed. Before tightening setscrew, make certain that setscrew is over nearest flat surface of pulley hub (Fig. 26).

⚠ CAUTION

UNIT OPERATION HAZARD

Failure to follow this caution could cause equipment damage.

Increasing fan speed produces a greater load on motor. Do not exceed rated capacity of motor.

Condensate Drains - Keep condensate drains free of dirt and foreign matter.

Return-Air Filters - Refer to Replacing Filters section for filter accessibility and removal. Replace with clean filters of the sizes listed in Tables 1A-1F.

Chilled Water Coil Freeze Protection - Shut off water supply to unit. Remove side panel of unit and remove vent and drain plugs in top and bottom of coil header. Drain coil and blow out remaining water. Reinstall plugs and side panel.

Alternative freeze protection methods follow:

- Circulate hot water within the water coil's supply main or supplementary space heating.
- Close off supply lines to unit and open a union or field-supplied drain valve in the return line.

IMPORTANT: Draining from return line will not completely drain water from coils.

- After draining as much water as possible from coils, add sufficient antifreeze to prevent residual water in the coil from freezing.
- Add a sufficient quantity of non-corrosive antifreeze to the entire system to prevent all water within the system from freezing.

Coil Removal - Remove unit panels and corner posts as required. Disconnect coil connections and remove fastening screws. Remove coil through end or side sections of unit.

Cleaning Cooling Coil - Remove return-air filters. Remove any heavy dirt that may have accumulated on underside of coil. Coil can be cleaned more easily with a stiff brush, vacuum cleaner, or compressed air when coil is dry. If coil is wet or if water is to be used for cleaning, guard against splashing water on electrical components or damaging surrounding area. Clean coil baffles as applicable and check for tight fit to be sure air does not bypass coil.

Cleaning Insulation - The insulation contains an immobilized antimicrobial agent that helps prevent the growth of bacteria and fungi. Clean the inner surface of the insulation according to the separate maintenance instructions shipped with the unit.

Replacing Filters - Filters can be removed and installed from either side of the unit. Install new filters in units that have one fan as follows:

1. Remove the side access panel (retain screws).
2. Remove the filter retainer clip (see Fig. 27).
3. Remove old filters by lifting and tilting them out of the filter track. See Fig. 15 and 28.
4. Reverse the procedure to install new filters.

To install new filters in larger units that have 2 fans, follow the preceding steps, but use the factory-supplied filter hook to slide filters within reach for removal. The filter hook is shipped inside the unit in the filter track.

⚠ CAUTION

UNIT OPERATION HAZARD

Failure to follow this caution could cause equipment damage.

Do not operate unit without air filters.

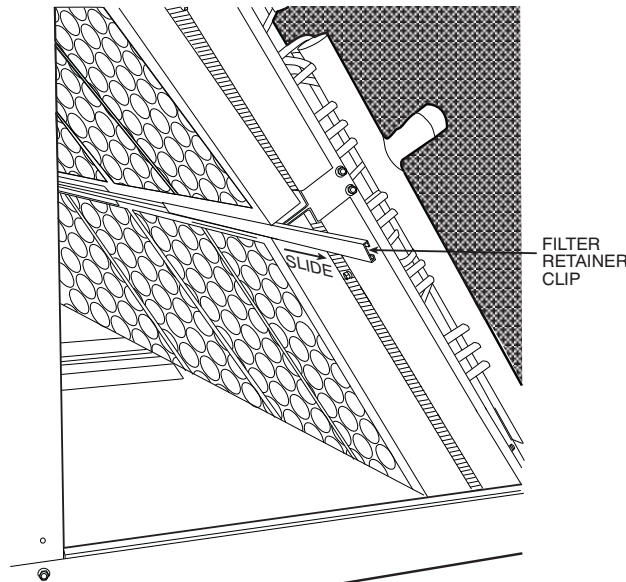

Fig. 27 - Remove Filter Retainer Clip

C10703

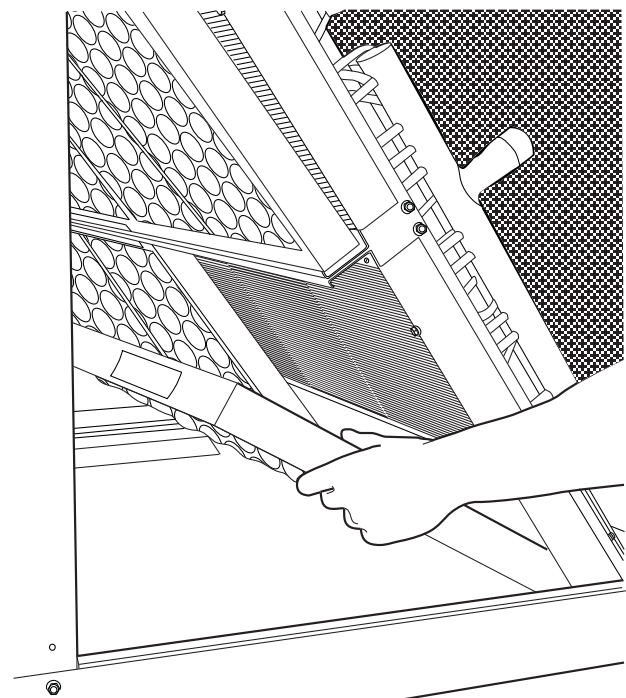

Fig. 28 - Filter Removal/Replacement

C10704

40RU

Table 10 – Fan Motor Data, 40RUA/Q/S Standard Motor, Single Speed — English

UNIT	40RUA/Q 07	40RUA/Q/S 08	40RUS 10	40RUA/Q/S 12	40RUA/S 14	40RUA/Q/S 16
208/230-1-60						
Speed (rpm)	1725	1725	1725	—	—	—
Hp	1.3	2.4	2.4	—	—	—
Frame (NEMA)	56Y	56Y	56Y	—	—	—
Shaft Dia (in.)	5/8	5/8	5/8	—	—	—
208/230-3-60 and 460-3-60						
Speed (rpm)	1750	1750	1750	1750	1750	1750
Hp	2.4	2.4	2.4	2.4	2.9	3.7
Frame (NEMA)	56Y	56Y	56Y	56Y	56Y	56HZ
Shaft Dia (in.)	5/8	5/8	5/8	5/8	7/8	7/8
575-3-60						
Speed (rpm)	1725	1725	1725	1725	1725	1725
Hp	1.0	2.0	2.0	2.0	3.0	3.0
Frame (NEMA)	56	56HZ	56HZ	56HZ	56HZ	56HZ
Shaft Dia (in.)	5/8	7/8	7/8	7/8	7/8	7/8

LEGEND:

NEMA — National Electrical Manufacturers Association (U.S.A.)

Table 11 – Fan Motor Data, 40RUA/Q/S Alternate Motor, Single Speed — English

UNIT	40RUA/Q 07	40RUA/Q/S 08	40RUS 10	40RUA/Q/S 12	40RUA/S 14	40RUA/Q/S 16
208/230-1-60						
Speed (rpm)	1725	1725	1725	—	—	—
Hp	2.4	2.4	2.4	—	—	—
Frame (NEMA)	56Y	56Y	56Y	—	—	—
Shaft Dia (in.)	5/8	5/8	5/8	—	—	—
230-3-60 and 460-3-60						
Speed (rpm)	1750	1750	1750	1750	1750	1755
Hp	2.9	2.9	2.9	3.7	3.7	5.0
Frame (NEMA)	56Y	56Y	56Y	56HZ	56HZ	184T
Shaft Dia (in.)	7/8	7/8	7/8	7/8	7/8	1 1/8
575-3-60						
Speed (rpm)	1725	1725	1725	1725	1755	1755
Hp	2.0	3.0	3.0	3.0	5.0	5.0
Frame (NEMA)	56HZ	56HZ	56HZ	56HZ	184T	184T
Shaft Dia (in.)	7/8	7/8	7/8	7/8	1 1/8	1 1/8

LEGEND:

NEMA — National Electrical Manufacturers Association (U.S.A.)

MOTOR EFFICIENCY 40RUA/Q/S

MOTOR HP	EPACT MINIMUM	MOTOR EFFICIENCY
1.3*	—	70.0%
2.4	—	76.8%
2.9	—	77.1%
3.7	—	81.5%
5.0	89.5%	89.5%

LEGEND:

EPACT – Energy Policy and Conservation Act of 1992

* Single-phase only.

Table 12 – Fan Motor Data, 40RUA/Q/S Standard Motor, Single Speed — SI

UNIT	40RUA/Q 07	40RUA/Q/S 08	40RUS 10	40RUA/Q/S 12	40RUA/S 14	40RUA/Q/S 16
208/230-1-60						
Speed (r/s)	28.75	28.75	28.75	—	—	—
Shaft kW	0.97	1.79	1.79	—	—	—
Frame (NEMA)	56Y	56Y	56Y	—	—	—
Shaft Dia (mm)	15.9	15.9	15.9	—	—	—
208/230-3-60 and 460-3-60						
Speed (r/s)	29.17	29.17	29.17	29.17	29.17	29.17
Shaft kW	1.79	1.79	1.79	1.79	2.16	2.76
Frame (NEMA)	56Y	56Y	56Y	56Y	56Y	56HZ
Shaft Dia (mm)	15.9	15.9	15.9	15.9	22.2	22.2
575-3-60						
Speed (r/s)	28.75	28.75	28.75	28.75	28.75	28.75
Shaft kW	0.75	1.49	1.49	1.49	2.24	2.24
Frame (NEMA)	56	56HZ	56HZ	56HZ	56HZ	56HZ
Shaft Dia (mm)	15.9	22.2	22.2	22.2	22.2	22.2

LEGEND:

NEMA — National Electrical Manufacturers Association (U.S.A.)

Table 13 – Fan Motor Data, 40RUA/Q/S Alternate Motor, Single Speed — SI

UNIT	40RUA/Q 07	40RUA/Q/S 08	40RUS 10	40RUA/Q/S 12	40RUA/S 14	40RUA/Q/S 16
208/230-1-60						
Speed (r/s)	28.75	28.75	28.75	—	—	—
Shaft kW	1.79	1.79	1.79	—	—	—
Frame (NEMA)	56Y	56Y	56Y	—	—	—
Shaft Dia (mm)	15.9	15.9	15.9	—	—	—
208/230-3-60 and 460-3-60						
Speed (r/s)	29.17	29.17	29.17	29.17	29.17	29.25
Shaft kW	2.16	2.16	2.16	2.76	2.76	3.73
Frame (NEMA)	56Y	56Y	56Y	56HZ	56HZ	184T
Shaft Dia (mm)	22.2	22.2	22.2	22.2	22.2	28.6
575-3-60						
Speed (r/s)	28.75	28.75	28.75	28.75	29.25	29.25
Shaft kW	1.49	2.24	2.24	2.24	3.73	3.73
Frame (NEMA)	56HZ	56HZ	56HZ	56HZ	184T	184T
Shaft Dia (mm)	22.2	22.2	22.2	22.2	28.6	28.6

LEGEND:

NEMA — National Electrical Manufacturers Association (U.S.A.)

40RU

Table 14 – Fan Motor Data, 40RUA/S Standard Motor, Two Speed — English

UNIT	40RUA 07	40RUA/S 08	40RUS 10	40RUA/S 12	40RUA/S 14	40RUA/S 16
208/230–3–60 and 460–3–60						
Speed (rpm)	1680	1680	1680	1680	1735	1750
Hp	2.4	2.4	2.4	2.4	2.9	3.7
Frame (NEMA)	56HY	56HY	56HY	56HY	56HY	56HY
Shaft Dia (in.)	5/8	5/8	5/8	5/8	7/8	7/8
575-3-60						
Speed (rpm)	1680	1680	1680	1680	1710	1710
Hp	2.4	2.4	2.4	2.4	3.7	3.7
Frame (NEMA)	56HY	56HY	56HZ	56HY	56HY	56HY
Shaft Dia (in.)	5/8	5/8	5/8	5/8	7/8	7/8

Table 15 – Fan Motor Data, 40RUA/S Alternate Motor, Two Speed — English

UNIT	40RUA 07	40RUA/S 08	40RUS 10	40RUA/S 12	40RUA/S 14	40RUA/S 16
208/230–3–60 and 460–3–60						
Speed (rpm)	1750	1750	1750	1750	1750	1755
Hp	3.7	3.7	3.7	3.7	3.7	5.0
Frame (NEMA)	56HY	56HY	56HY	56HY	56HY	184T
Shaft Dia (in.)	7/8	7/8	7/8	7/8	7/8	1 1/8
575-3-60						
Speed (rpm)	1710	1710	1710	1710	1755	1755
Hp	3.7	3.7	3.7	3.7	5.0	5.0
Frame (NEMA)	56HY	56HY	56HY	56HY	184T	184T
Shaft Dia (in.)	7/8	7/8	7/8	7/8	1 1/8	1 1/8

MOTOR EFFICIENCY 40RUA/S – Two Speed Motors

MOTOR HP	EPACT MINIMUM	MOTOR EFFICIENCY
2.4	–	80.0%
2.9	–	86.5%
3.7	–	83.6%
5.0	89.5%	89.5%

LEGEND:

EPACT – Energy Policy and Conservation Act of 1992

Table 16 – Fan Motor Data, 40RUA/S Standard Motor, Two Speed — SI

UNIT	40RUA 07	40RUA/S 08	40RUS 10	40RUA/S 12	40RUA/S 14	40RUA/S 16
208/230–3–60 and 460–3–60						
Speed (r/s)	28.00	28.00	28.00	28.00	28.92	29.17
Shaft kW	1.79	1.79	1.79	1.79	2.16	2.76
Frame (NEMA)	56HY	56HY	56HY	56HY	56HY	56HY
Shaft Dia (mm)	15.9	15.9	15.9	15.9	22.2	22.2
575-3-60						
Speed (rpm)	28.00	28.00	28.00	28.00	28.50	28.50
Hp	1.79	1.79	1.79	1.79	2.76	2.76
Frame (NEMA)	56HY	56HY	56HY	56HY	56HY	56HY
Shaft Dia (in.)	15.9	15.9	15.9	15.9	22.2	22.2

Table 17 – Fan Motor Data, 40RUA/S Alternate Motor, Two Speed — SI

UNIT	40RUA 07	40RUA/S 08	40RUS 10	40RUA/S 12	40RUA/S 14	40RUA/S 16
208/230–3–60 and 460–3–60						
Speed (r/s)	29.17	29.17	29.17	29.17	29.17	29.25
Shaft kW	2.76	2.76	2.76	2.76	2.76	3.73
Frame (NEMA)	56HY	56HY	56HY	56HY	56HY	184T
Shaft Dia (mm)	22.2	22.2	22.2	22.2	22.2	28.6
575-3-60						
Speed (rpm)	28.50	28.50	28.50	28.50	29.25	29.25
Hp	2.76	2.76	2.76	2.76	3.73	3.73
Frame (NEMA)	56HY	56HY	56HY	56HY	184T	184T
Shaft Dia (in.)	22.2	22.2	22.2	22.2	28.6	28.6

40RU

Table 18 – Fan Motor Data, 40RUQ Standard Motor, Two Speed — English

UNIT	40RUQ 07	40RUQ 08	40RUQ 12	40RUQ 16
208/230–3–60 and 460–3–60				
Speed (rpm)	1680	1680	1680	1750
Hp	2.4	2.4	1.7	3.7
Frame (NEMA)	56HY	56HY	56HY	56HY
Shaft Dia (in.)	5/8	5/8	5/8	7/8
575-3-60				
Speed (rpm)	1680	1680	1665	1710
Hp	2.4	2.4	1.7	3.7
Frame (NEMA)	56HY	56HY	56HY	56HY
Shaft Dia (in.)	5/8	5/8	5/8	7/8

Table 19 – Fan Motor Data, 40RUQ Alternate Motor, Two Speed — English

UNIT	40RUQ 07	40RUQ 08	40RUQ 12	40RUQ 16
208/230–3–60 and 460–3–60				
Speed (rpm)	1750	1750	1725	1755
Hp	3.7	3.7	3.7*	5.0
Frame (NEMA)	56HY	56HY	56HY	184T
Shaft Dia (in.)	7/8	7/8	7/8	1 1/8
575-3-60				
Speed (rpm)	1710	1710	1710	1755
Hp	3.7	3.7	3.7	5.0
Frame (NEMA)	56HY	56HY	56HY	184T
Shaft Dia (in.)	7/8	7/8	7/8	1 1/8

* High Efficiency Motor

MOTOR EFFICIENCY 40RUQ – Two Speed Motors

MOTOR HP	EPACT MINIMUM	MOTOR EFFICIENCY
1.7	–	82.0%
2.4	–	80.0%
2.9	–	86.5%
3.7	–	83.6%
3.7*	–	87.9%
5.0	89.5%	87.9%

LEGEND:

EPACT – Energy Policy and Conservation Act of 1992

* High Efficiency Motor

Table 20 – Fan Motor Data, 40RUQ Standard Motor, Two Speed — SI

UNIT	40RUQ 07	40RUQ 08	40RUQ 12	40RUQ 16
208/230–3–60 and 460–3–60				
Speed (r/s)	28.00	28.00	28.17	29.17
Shaft kW	1.79	1.79	1.27	2.76
Frame (NEMA)	56HY	56HY	56HY	56HY
Shaft Dia (mm)	15.9	15.9	15.9	22.2
575-3-60				
Speed (rpm)	28.00	28.00	27.75	28.50
Hp	1.79	1.79	1.27	2.76
Frame (NEMA)	56HY	56HY	56HY	56HY
Shaft Dia (in.)	15.9	15.9	15.9	22.2

Table 21 – Fan Motor Data, 40RUQ Alternate Motor, Two Speed — SI

UNIT	40RUQ 07	40RUQ 08	40RUQ 12	40RUQ 16
208/230–3–60 and 460–3–60				
Speed (r/s)	29.17	29.17	28.75	29.25
Shaft kW	2.76	2.76	2.76	3.73
Frame (NEMA)	56HY	56HY	56HY	184T
Shaft Dia (mm)	22.2	22.2	22.2	28.6
575-3-60				
Speed (rpm)	28.50	28.50	28.50	29.25
Hp	2.76	2.76	2.76	3.73
Frame (NEMA)	56HY	56HY	56HY	184T
Shaft Dia (in.)	22.2	22.2	22.2	28.6

40RU

Table 22 – Standard Drive Data, 60 Hz — English

UNIT	40RUA/Q 07	40RUA/Q/S 08	40RUS 10	40RUA/Q/S 12	40RUA/S 14	40RUA/Q/S 16
MOTOR DRIVE						
Motor Pulley Pitch Diameter (in.)	2.4-3.4	2.8-3.8	2.8-3.8	3.4-4.4	2.8-3.8	2.8-3.8
Pulley Factory Setting Full Turns Open	2.5	2.5	2.5	2.5	2.5	2.5
FAN DRIVE						
Pulley Pitch Dia (in.)	8.8	8.8	8.8	8.8	9.0	9.0
Pulley Bore (in.)	1	1	1	1	1 ⁷ / ₁₆	1 ⁷ / ₁₆
Belt No. — Section	1—A	1—A	1—A	1—A	1—A	1—A
Belt Pitch (in.)	40.3	41.3	41.3	42.3	42.3	42.3
FAN SPEEDS (rpm)						
Factory Settings	568	647	647	764	632	632
Range	470-666	549-745	549-745	666-863	537-728	537-728
Max Allowable Speed (rpm)	1200	1200	1200	1200	1200	1200
Change per 1/2 turn of Moveable Motor Pulley Flange	19.6	19.6	19.6	19.7	19.1	19.1
MAX FULL TURNS FROM CLOSED POSITION	5	5	5	5	5	5
SHAFTS CENTER DISTANCE (in.)	10.44- 12.32	10.44- 12.32	10.44- 12.32	10.44- 12.32	10.44- 12.32	10.44- 12.32

Table 23 – Medium-Static Drive Data, 60 Hz — English

UNIT	40RUA/Q 07	40RUA/Q/S 08	40RUS 10	40RUA/Q/S 12	40RUA/S 14	40RUA/Q/S 16
MOTOR DRIVE						
Motor Pulley Pitch Diameter (in.)	3.4-4.4	3.4-4.4	3.4-4.4	3.4-4.4	3.4-4.4	3.7-4.7
Pulley Factory Setting Full Turns Open	2.5	2.5	2.5	2.5	2.5	3.0
FAN DRIVE						
Pulley Pitch Dia (in.)	8.8	8.0	8.0	8.0	8.2	8.6
Pulley Bore (in.)	1	1	1	1	1 ⁷ / ₁₆	1 ⁷ / ₁₆
Belt No. — Section	1—A	1—A	1—A	1—A	1—A	1—B
Belt Pitch (in.)	42.3	40.3	40.3	40.3	41.3	41.8
FAN SPEEDS (rpm)						
Factory Setting	764	841	841	841	820	842
Range	666-863	733-949	733-949	733-949	715-926	742-943
Max Allowable Speed (rpm)	1200	1200	1200	1200	1200	1200
Change per 1/2 Turn of Moveable Motor Pulley Flange	19.7	21.6	21.6	21.6	21.1	16.7
MAX FULL TURNS FROM CLOSED POSITION	5	5	5	5	5	6
SHAFTS CENTER DISTANCE (in.)	10.44- 12.32	10.44- 12.32	10.44- 12.32	10.44- 12.32	10.44- 12.32	10.44- 12.32

40RU

Table 24 – High-Static Drive Data, 60 Hz — English

UNIT	40RUA/Q 07	40RUA/Q/S 08	40RUS 10	40RUA/Q/S 12	40RUA/S 14	40RUA/Q/S 16
MOTOR DRIVE						
Motor Pulley Pitch Diameter (in.)	3.4-4.4	3.4-4.4	3.4-4.4	3.4-4.4	3.7-4.7	4.3-5.3
Pulley Factory Setting Full Turns Open	2.5	2.5	2.5	2.5	3.0	3.0
FAN DRIVE						
Pulley Pitch Dia (in.)	7.0	6.0*	6.0	6.0	7.4	7.9
Pulley Bore (in.)	1	1	1	1	1 ⁷ / ₁₆	1 ⁷ / ₁₆
Belt No. — Section	1—A	1—A	1—A	1—A	1—B	1—B
Belt Pitch (in.)	41.3	37.3	37.3	37.3	39.8	39.8
FAN SPEEDS (rpm)						
Factory Setting	961	1121	1121	1121	979	1060
Range	838- 1084	978- 1200*†	978- 1200†	978- 1200†	873- 1096	950- 1171
Max Allowable Speed (rpm)	1200	1200	1200	1200	1200	1200
Change per 1/2 Turn of Moveable Motor Pulley Flange	24.6	28.7	28.7	28.7	19.4	18.4
MAX FULL TURNS FROM CLOSED POSITION						
	5	5	5	5	6	6
SHAFTS CENTER DISTANCE (in.)	10.44- 12.32	10.44- 12.32	10.44- 12.32	10.44- 12.32	10.44- 12.32**	9.16- 10.99

* Values for 3-phase motor shown. For single-phase motor, pulley pitch diameter is 7 in. and resulting fan speed is 837-1096 rpm.

† It is possible to adjust drive so that fan speed exceeds maximum allowable. DO NOT exceed 1200 rpm.

** 575-v unit has a center distance of 9.16-10.99.

Table 25 – Standard Drive Data, 60 Hz — SI

UNIT	40RUA/Q 07	40RUA/Q/S 08	40RUS 10	40RUA/Q/S 12	40RUA/S 14	40RUA/Q/S 16
MOTOR DRIVE						
Motor Pulley Pitch Diameter (mm)	61.0- 86.4	71.1- 96.5	71.1- 96.5	86.4- 111.8	71.1- 96.5	71.1- 96.5
Pulley Factory Setting Full Turns Open	2.5	2.5	2.5	2.5	2.5	2.5
FAN DRIVE						
Pulley Pitch Dia (mm)	224	224	224	224	229	229
Pulley Bore (mm)	25.4	25.4	25.4	25.4	36.5	36.5
Belt No. — Section	1—A	1—A	1—A	1—A	1—A	1—A
Belt Pitch (mm)	1024	1049	1049	1074	1074	1074
FAN SPEEDS (r/s)						
Factory Setting	9.5	10.8	10.8	12.7	10.5	10.5
Range	7.8-11.1	9.2-12.4	9.2-12.4	11.1-14.4	9.0-12.1	9.0-12.1
Max Allowable Speed (r/s)	20.0	20.0	20.0	20.0	20.0	20.0
Change per 1/2 Turn of Moveable Motor Pulley Flange	0.327	0.327	0.327	0.328	0.318	0.318
MAX FULL TURNS FROM CLOSED POSITION						
	5	5	5	5	5	5
SHAFTS CENTER DISTANCE (mm)	265-313	265-313	265-313	265-313	265-313	265-313

40RU

Table 26 – Medium-Static Drive Data, 60 Hz — SI

UNIT	40RUA/Q 07	40RUA/Q/S 08	40RUS 10	40RUA/Q/S 12	40RUA/S 14	40RUA/Q/S 16
MOTOR DRIVE						
Motor Pulley Pitch Diameter (mm)	86.4- 111.8	86.4- 111.8	86.4- 111.8	86.4- 111.8	86.4- 111.8	94.0- 119.4
Pulley Factory Setting Full Turns Open	2.5	2.5	2.5	2.5	2.5	3.0
FAN DRIVE						
Pulley Pitch Dia (mm)	224	203	203	203	208	218
Pulley Bore (mm)	25.4	25.4	25.4	25.4	36.5	36.5
Belt No. — Section	1—A	1—A	1—A	1—A	1—A	1—B
Belt Pitch (mm)	1074	1024	1024	1024	1049	1062
FAN SPEEDS (r/s)						
Factory Setting	12.7	14.0	14.0	14.0	13.7	14.0
Range	11.1- 14.4	12.2- 15.8	12.2- 15.8	12.2- 15.8	11.9- 15.4	12.4- 15.7
Max Allowable Speed (r/s)	20.0	20.0	20.0	20.0	20.0	20.0
Change per 1/2 Turn of Moveable Motor Pulley Flange	0.328	0.360	0.360	0.360	0.352	0.278
MAX FULL TURNS FROM CLOSED POSITION	5	5	5	5	6	6
SHAFTS CENTER DISTANCE (mm)	265-313	265-313	265-313	265-313	265-313	265-313

Table 27 – High-Static Drive Data, 60 Hz — SI

UNIT	40RUA/Q 07	40RUA/Q/S 08	40RUS 10	40RUA/Q/S 12	40RUA/S 14	40RUA/Q/S 16
MOTOR DRIVE						
Motor Pulley Pitch Diameter (mm)	86.4- 111.8	86.4- 111.8	86.4- 111.8	86.4- 111.8	94.0- 119.4	109.2- 134.6
Pulley Factory Setting Full Turns Open	2.5	2.5	2.5	2.5	3.0	3.0
FAN DRIVE						
Pulley Pitch Dia (mm)	178	152*	152	152	188	201
Pulley Bore (mm)	25.4	25.4	25.4	25.4	36.5	36.5
Belt No. — Section	1—A	1—A	1—A	1—A	1—B	1—B
Belt Pitch (mm)	1049	947	947	947	1011	1011
FAN SPEEDS (r/s)						
Factory Setting	16.0	18.7	18.7	18.7	16.3	17.7
Range	14.0- 18.1	16.3- 20.0*†	16.3- 20.0†	16.3- 20.0†	14.4- 18.3	15.8- 19.5
Max Allowable Speed (r/s)	20.0	20.0	20.0	20.0	20.0	20.0
Change per 1/2 Turn of Moveable Motor Pulley Flange	0.410	0.478	0.478	0.478	0.323	0.307
MAX FULL TURNS FROM CLOSED POSITION	5	5	5	5	6	6
SHAFTS CENTER DISTANCE (mm)	265-313	265-313	265-313	265-313	265-313**	232-279

* Values for 3-phase motor shown. For single-phase motor, pulley pitch diameter is 178 mm and resulting fan speed is 14.0-18.3 r/s.

† It is possible to adjust drive so that fan speed exceeds maximum allowable. DO NOT exceed 20 r/s.

** 575-v unit has a center distance of 233-279.

40RU

Table 28 – FAN PERFORMANCE DATA — 40RU
0.0-1.2 in. wg ESP — 60 Hz, English

UNIT	AIRFLOW (Cfm)	EXTERNAL STATIC PRESSURE (in. wg)													
		0.0		0.2		0.4		0.6		0.8		1.0		1.2	
		Rpm	Bhp	Rpm	Bhp	Rpm	Bhp	Rpm	Bhp	Rpm	Bhp	Rpm	Bhp	Rpm	Bhp
40RUA*07 40RUQ*07	1,800	419	0.21	471	0.26	564	0.37	649	0.49	<u>727</u>	<u>0.63</u>	<u>797</u>	<u>0.77</u>	<u>862</u>	<u>0.92</u>
	2,100	471	0.31	519	0.37	602	0.49	<u>679</u>	<u>0.62</u>	<u>751</u>	<u>0.77</u>	<u>819</u>	<u>0.92</u>	<u>882</u>	<u>1.09</u>
	2,400	524	0.44	568	0.51	645	0.64	<u>715</u>	<u>0.79</u>	<u>781</u>	<u>0.94</u>	<u>844</u>	<u>1.11</u>	<u>905</u>	<u>1.28</u>
	2,700	578	0.61	619	0.69	<u>690</u>	<u>0.84</u>	<u>755</u>	<u>0.99</u>	<u>816</u>	<u>1.15</u>	<u>875</u>	<u>1.33</u>	<u>932</u>	<u>1.51</u>
	3,000	633	0.81	<u>671</u>	<u>0.90</u>	<u>738</u>	<u>1.07</u>	<u>799</u>	<u>1.24</u>	<u>856</u>	<u>1.41</u>	<u>910</u>	<u>1.60</u>	<u>963</u>	<u>1.79</u>
40RUA*08 40RUQ*08 40RUS*08	2,250	290	0.10	510	0.39	594	0.51	669	0.65	739	0.79	<u>806</u>	<u>0.95</u>	<u>870</u>	<u>1.12</u>
	2,600	349	0.19	561	0.55	640	0.70	709	0.84	<u>773</u>	<u>1.00</u>	<u>834</u>	<u>1.16</u>	<u>893</u>	<u>1.34</u>
	3,000	579	0.70	621	0.79	695	0.96	<u>759</u>	<u>1.12</u>	<u>818</u>	<u>1.30</u>	<u>874</u>	<u>1.47</u>	<u>928</u>	<u>1.66</u>
	3,400	646	0.99	683	1.09	<u>752</u>	<u>1.29</u>	<u>813</u>	<u>1.48</u>	<u>869</u>	<u>1.67</u>	<u>920</u>	<u>1.86</u>	<u>970</u>	<u>2.06</u>
	3,750	705	1.31	739	1.42	<u>804</u>	<u>1.63</u>	<u>862</u>	<u>1.85</u>	<u>915</u>	<u>2.05</u>	<u>964</u>	<u>2.26</u>	<u>1011</u>	<u>2.48</u>
40RUS*10	2,550	396	0.42	502	0.54	586	0.65	658	0.76	722	0.87	<u>780</u>	<u>0.97</u>	<u>833</u>	<u>1.08</u>
	2,975	462	0.60	556	0.72	634	0.84	701	0.95	<u>762</u>	<u>1.06</u>	<u>818</u>	<u>1.18</u>	<u>870</u>	<u>1.29</u>
	3,400	527	0.80	612	0.93	684	1.06	<u>748</u>	<u>1.18</u>	<u>806</u>	<u>1.30</u>	<u>860</u>	<u>1.41</u>	<u>910</u>	<u>1.53</u>
	3,825	593	1.05	670	1.18	737	1.31	<u>797</u>	<u>1.44</u>	<u>852</u>	<u>1.56</u>	<u>904</u>	<u>1.68</u>	<u>952</u>	<u>1.80</u>
	4,250	659	1.33	729	1.47	<u>791</u>	<u>1.60</u>	<u>848</u>	<u>1.73</u>	<u>901</u>	<u>1.86</u>	<u>950</u>	<u>1.98</u>	<u>997</u>	<u>2.11</u>
40RUA*12 40RUQ*12 40RUS*12	3,000	421	0.35	592	0.73	670	0.90	737	1.06	<u>797</u>	<u>1.23</u>	<u>854</u>	<u>1.41</u>	<u>908</u>	<u>1.59</u>
	3,500	626	0.98	664	1.08	735	1.28	798	1.48	<u>855</u>	<u>1.67</u>	<u>908</u>	<u>1.87</u>	<u>958</u>	<u>2.07</u>
	4,000	706	1.42	738	1.54	803	1.77 [†]	862	2.00 [†]	<u>917</u>	<u>2.23</u>	<u>967</u>	<u>2.45</u>	<u>1014</u>	<u>2.67</u>
	4,500	786	1.99 [†]	815	2.12 [†]	<u>873</u>	<u>2.39</u>	<u>929</u>	<u>2.65</u>	<u>980</u>	<u>2.90</u>	<u>1028</u>	<u>3.16</u>	<u>1073</u>	<u>3.41</u>
	5,000	867	2.70	<u>893</u>	<u>2.84</u>	<u>946</u>	<u>3.14</u>	<u>997</u>	<u>3.43</u>	<u>1046</u>	<u>3.72</u>	<u>1092</u>	<u>4.00</u>	<u>1135</u>	<u>4.28</u>
40RUA*14 40RUS*14	3,750	410	0.43	467	0.55	567	0.83	649	1.12	721	1.41	<u>788</u>	<u>1.72</u>	<u>851</u>	<u>2.05</u>
	4,300	455	0.62	504	0.74	599	1.05	679	1.38	<u>748</u>	<u>1.70</u>	<u>811</u>	<u>2.04</u>	<u>871</u>	<u>2.39</u>
	5,000	514	0.92	556	1.06	641	1.39	718	1.76	<u>786</u>	<u>2.14</u>	<u>847</u>	<u>2.52</u>	<u>903</u>	<u>2.91</u>
	5,700	575	1.32	612	1.47	686	1.82	<u>759</u>	<u>2.23</u>	<u>825</u>	<u>2.66</u>	<u>884</u>	<u>3.09</u>	<u>939</u>	<u>3.52</u>
	6,250	624	1.71	657	1.87	725	2.24	<u>793</u>	<u>2.66</u>	<u>856</u>	<u>3.12</u>	<u>915</u>	<u>3.59</u>	<u>969</u>	<u>4.06</u>
40RUA*16 40RUQ*16 40RUS*16	4,500	437	0.61	483	0.72	576	1.01	660	1.35	<u>732</u>	<u>1.69</u>	<u>797</u>	<u>2.03</u>	<u>856</u>	<u>2.38</u>
	5,300	499	0.95	538	1.07	617	1.37	696	1.74	<u>767</u>	<u>2.13</u>	<u>830</u>	<u>2.53</u>	<u>888</u>	<u>2.94</u>
	6,000	555	1.34	590	1.48	659	1.79	<u>730</u>	<u>2.17</u>	<u>798</u>	<u>2.59</u>	<u>860</u>	<u>3.04</u>	<u>918</u>	<u>3.49</u>
	6,800	620	1.91	651	2.06	712	2.39	<u>774</u>	<u>2.78</u>	<u>836</u>	<u>3.22</u>	<u>896</u>	<u>3.71</u>	<u>952</u>	<u>4.21</u>
	7,500	677	2.52	706	2.69	<u>761</u>	<u>3.04</u>	<u>817</u>	<u>3.44</u>	<u>873</u>	<u>3.89</u>	<u>929</u>	<u>4.39</u>	<u>984</u>	<u>4.93</u>

40RU

LEGEND

Bhp — Brake Horsepower Input to Fan
 ESP — External Static Pressure
Bold indicates field-supplied drive is required.
 Plain type indicates standard motor and standard drive.
Underline indicates a different motor and drive combination other than the standard motor and standard drive combination is required.
 Refer to fan motor and drive tables to complete selection.
[†] — For 40RUQ*12, these operating points require different motor and drive combination.

NOTES:

- Maximum allowable fan speed is 1200 rpm for all sizes.
- Fan performance is based on deductions for wet coil, clean 2-in. filters, and unit casing. See table at right for factory-supplied filter pressure drop.
- Refer to fan motor and drive tables for additional data.

FACTORY-SUPPLIED PRESSURE DROP — ENGLISH

UNIT	AIRFLOW (Cfm)	PRESSURE DROP (in. wg)
40RUA*07 40RUQ*07	850	0.05
	1,150	0.08
	1,450	0.11
40RUA*08	2,250	0.07
40RUQ*08	3,000	0.11
40RUS*08	3,750	0.15
40RUS*10	2,550	0.09
	3,400	0.13
	4,250	0.18
40RUA*12 40RUQ*12 40RUS*12	3,000	0.11
	4,000	0.17
	5,000	0.23
40RUA*14 40RUS*14	3,750	0.06
	5,000	0.10
	6,250	0.13
40RUA*16 40RUQ*16 40RUS*16	4,500	0.08
	6,000	0.12
	7,500	0.17

Table 29 – FAN PERFORMANCE DATA — 40RU
1.4-2.4 in. wg ESP — 60 Hz, English

UNIT	AIRFLOW (Cfm)	EXTERNAL STATIC PRESSURE (in. wg)											
		1.4		1.6		1.8		2.0		2.2		2.4	
		Rpm	Bhp	Rpm	Bhp	Rpm	Bhp	Rpm	Bhp	Rpm	Bhp	Rpm	Bhp
40RUA*07 40RUQ*07	1,800	<u>921</u>	<u>1.07</u>	<u>975</u>	<u>1.23</u>	<u>1026</u>	<u>1.39</u>	<u>1074</u>	<u>1.55</u>	1120	1.72	1164	1.90
	2,100	<u>942</u>	<u>1.26</u>	<u>997</u>	<u>1.43</u>	<u>1048</u>	<u>1.61</u>	1097	1.79	1143	1.97	1186	2.16
	2,400	<u>963</u>	<u>1.47</u>	<u>1017</u>	<u>1.66</u>	<u>1069</u>	<u>1.85</u>	1118	2.05	1164	2.25	—	—
	2,700	<u>987</u>	<u>1.71</u>	<u>1039</u>	<u>1.91</u>	1090	2.12	1138	2.33	1185	2.55	—	—
	3,000	<u>1015</u>	<u>1.99</u>	<u>1065</u>	<u>2.20</u>	1113	2.42	1161	2.65	—	—	—	—
40RUA*08 40RUQ*08 40RUS*08	2,250	<u>930</u>	<u>1.29</u>	<u>986</u>	<u>1.47</u>	<u>1039</u>	<u>1.65</u>	<u>1089</u>	<u>1.84</u>	<u>1136</u>	<u>2.03</u>	<u>1181</u>	<u>2.22</u>
	2,600	<u>950</u>	<u>1.53</u>	<u>1005</u>	<u>1.72</u>	<u>1057</u>	<u>1.92</u>	<u>1107</u>	<u>2.13</u>	<u>1154</u>	<u>2.33</u>	—	—
	3,000	<u>980</u>	<u>1.86</u>	<u>1031</u>	<u>2.06</u>	<u>1081</u>	<u>2.27</u>	<u>1129</u>	<u>2.49</u>	<u>1175</u>	<u>2.72</u>	—	—
	3,400	<u>1018</u>	<u>2.26</u>	<u>1065</u>	<u>2.48</u>	1111	2.70	1156	2.93	—	—	—	—
	3,750	<u>1057</u>	<u>2.69</u>	<u>1101</u>	<u>2.92</u>	1144	3.15	1186	3.39	—	—	—	—
40RUS*10	2,550	<u>884</u>	<u>1.18</u>	<u>931</u>	<u>1.29</u>	<u>975</u>	<u>1.40</u>	<u>1018</u>	<u>1.50</u>	<u>1059</u>	<u>1.61</u>	—	—
	2,975	<u>919</u>	<u>1.40</u>	<u>965</u>	<u>1.51</u>	<u>1009</u>	<u>1.62</u>	<u>1050</u>	<u>1.73</u>	<u>1090</u>	<u>1.84</u>	—	—
	3,400	<u>957</u>	<u>1.64</u>	<u>1002</u>	<u>1.76</u>	<u>1044</u>	<u>1.87</u>	<u>1085</u>	<u>1.98</u>	<u>1124</u>	<u>2.10</u>	—	—
	3,825	<u>998</u>	<u>1.92</u>	<u>1041</u>	<u>2.04</u>	<u>1082</u>	<u>2.16</u>	<u>1122</u>	<u>2.27</u>	<u>1160</u>	<u>2.39</u>	—	—
	4,250	<u>1041</u>	<u>2.23</u>	<u>1083</u>	<u>2.35</u>	<u>1123</u>	<u>2.48</u>	<u>1161</u>	<u>2.60</u>	<u>1199</u>	<u>2.72</u>	—	—
40RUA*12 40RUQ*12 40RUS*12	3,000	<u>961</u>	<u>1.78</u>	<u>1012</u>	<u>1.98</u>	<u>1062</u>	<u>2.19</u>	<u>1111</u>	<u>2.41</u>	<u>1158</u>	<u>2.64</u>	—	—
	3,500	<u>1005</u>	<u>2.27</u>	<u>1052</u>	<u>2.49</u>	<u>1098</u>	<u>2.71</u>	<u>1142</u>	<u>2.94</u>	<u>1186</u>	<u>3.18</u>	—	—
	4,000	<u>1058</u>	<u>2.90</u>	<u>1101</u>	<u>3.13</u>	<u>1143</u>	<u>3.36</u>	<u>1184</u>	<u>3.60</u>	—	—	—	—
	4,500	<u>1116</u>	<u>3.66</u>	<u>1157</u>	<u>3.91</u>	<u>1196</u>	<u>4.16</u>	—	—	—	—	—	—
	5,000	<u>1176</u>	<u>4.56</u>	—	—	—	—	—	—	—	—	—	—
40RUA*14 40RUS*14	3,750	<u>912</u>	<u>2.39</u>	<u>971</u>	<u>2.76</u>	<u>1028</u>	<u>3.14</u>	<u>1083</u>	<u>3.54</u>	1135	3.95	1185	4.36
	4,300	<u>928</u>	<u>2.75</u>	<u>982</u>	<u>3.13</u>	<u>1036</u>	<u>3.53</u>	<u>1087</u>	<u>3.94</u>	1138	4.37	1187	4.81
	5,000	<u>956</u>	<u>3.30</u>	<u>1007</u>	<u>3.71</u>	<u>1056</u>	<u>4.13</u>	1104	4.56	1151	5.00	1196	5.46
	5,700	<u>990</u>	<u>3.96</u>	<u>1039</u>	<u>4.40</u>	<u>1086</u>	<u>4.85</u>	1130	5.31	1174	5.78	—	—
	6,250	<u>1019</u>	<u>4.54</u>	<u>1067</u>	<u>5.02</u>	1112	5.50	1156	5.99	1198	6.49	—	—
40RUA*16 40RUQ*16 40RUS*16	4,500	<u>912</u>	<u>2.75</u>	<u>967</u>	<u>3.12</u>	<u>1019</u>	<u>3.52</u>	<u>1070</u>	<u>3.92</u>	1120	4.35	1168	4.79
	5,300	<u>942</u>	<u>3.34</u>	<u>992</u>	<u>3.76</u>	<u>1041</u>	<u>4.18</u>	<u>1088</u>	<u>4.61</u>	1134	5.06	1179	5.52
	6,000	<u>971</u>	<u>3.95</u>	<u>1020</u>	<u>4.40</u>	<u>1067</u>	<u>4.86</u>	<u>1112</u>	<u>5.33</u>	1156	5.81	1198	6.29
	6,800	<u>1005</u>	<u>4.72</u>	<u>1054</u>	<u>5.23</u>	<u>1101</u>	<u>5.75</u>	<u>1145</u>	<u>6.27</u>	1187	6.79	—	—
	7,500	<u>1036</u>	<u>5.48</u>	<u>1084</u>	<u>6.04</u>	<u>1131</u>	<u>6.61</u>	<u>1174</u>	<u>7.17</u>	—	—	—	—

40RU

LEGEND

Bhp — Brake Horsepower Input to Fan

ESP — External Static Pressure

Bold indicates field-supplied drive is required.

Plain type indicates standard motor and standard drive.

Underline indicates a different motor and drive combination other than the standard motor and standard drive combination is required.

Refer to fan motor and drive tables to complete selection.

NOTES:

1. Maximum allowable fan speed is 1200 rpm for all sizes.
2. Fan performance is based on deductions for wet coil, clean 2-in. filters, and unit casing. See table at right for factory-supplied filter pressure drop.
3. Refer to fan motor and drive tables for additional data.

FACTORY-SUPPLIED PRESSURE DROP — ENGLISH

UNIT	AIRFLOW (Cfm)	PRESSURE DROP (in. wg)
40RUA*07 40RUQ*07	850	0.05
	1,150	0.08
	1,450	0.11
40RUA*08	2,250	0.07
40RUQ*08 40RUS*08	3,000	0.11
	3,750	0.15
40RUS*10	2,550	0.09
	3,400	0.13
	4,250	0.18
40RUA*12 40RUQ*12 40RUS*12	3,000	0.11
	4,000	0.17
	5,000	0.23
40RUA*14 40RUS*14	3,750	0.06
	5,000	0.10
	6,250	0.13
40RUA*16 40RUQ*16 40RUS*16	4,500	0.08
	6,000	0.12
	7,500	0.17

**Table 30 – FAN PERFORMANCE DATA — 40RU
0-300 Pa ESP — 60 Hz, SI**

UNIT	AIRFLOW (L/s)	EXTERNAL STATIC PRESSURE (Pa)													
		0		50		100		150		200		250		300	
		r/s	kW	r/s	kW	r/s	kW	r/s	kW	r/s	kW	r/s	kW	r/s	kW
40RUA*07 40RUQ*07	850	6.98	0.16	7.86	0.19	9.40	0.27	10.81	0.37	<u>12.11</u>	<u>0.47</u>	<u>13.29</u>	<u>0.57</u>	<u>14.36</u>	<u>0.69</u>
	990	7.84	0.23	8.64	0.27	10.03	0.36	<u>11.31</u>	<u>0.46</u>	<u>12.52</u>	<u>0.57</u>	<u>13.65</u>	<u>0.69</u>	<u>14.71</u>	<u>0.81</u>
	1130	8.73	0.33	9.46	0.38	10.75	0.48	<u>11.91</u>	<u>0.59</u>	<u>13.01</u>	<u>0.70</u>	<u>14.07</u>	<u>0.83</u>	<u>15.08</u>	<u>0.96</u>
	1270	9.63	0.45	10.31	0.51	<u>11.51</u>	<u>0.62</u>	<u>12.58</u>	<u>0.74</u>	<u>13.60</u>	<u>0.86</u>	<u>14.58</u>	<u>0.99</u>	<u>15.53</u>	<u>1.13</u>
	1420	0.55	0.61	<u>11.18</u>	<u>0.67</u>	<u>12.30</u>	<u>0.80</u>	<u>13.31</u>	<u>0.92</u>	<u>14.26</u>	<u>1.05</u>	<u>15.17</u>	<u>1.19</u>	<u>16.05</u>	<u>1.33</u>
40RUA*08 40RUQ*08 40RUS*08	1060	4.83	0.07	8.50	0.29	9.91	0.38	11.15	0.48	12.32	0.59	13.44	<u>0.71</u>	<u>14.50</u>	<u>0.83</u>
	1230	5.81	0.14	9.35	0.41	10.67	0.52	11.81	0.63	<u>12.88</u>	<u>0.74</u>	<u>13.90</u>	<u>0.87</u>	<u>14.89</u>	<u>1.00</u>
	1420	9.65	0.52	10.35	0.59	11.59	0.71	<u>12.66</u>	<u>0.84</u>	<u>13.64</u>	<u>0.97</u>	<u>14.57</u>	<u>1.10</u>	<u>15.47</u>	<u>1.24</u>
	1600	10.76	0.74	11.39	0.81	<u>12.54</u>	<u>0.96</u>	<u>13.55</u>	<u>1.10</u>	<u>14.48</u>	<u>1.24</u>	<u>15.34</u>	<u>1.39</u>	<u>16.17</u>	<u>1.53</u>
	1770	11.74	0.97	12.32	1.06	<u>13.40</u>	<u>1.22</u>	<u>14.37</u>	<u>1.38</u>	<u>15.25</u>	<u>1.53</u>	<u>16.07</u>	<u>1.69</u>	<u>16.86</u>	<u>1.85</u>
40RUS*10	1200	6.60	0.31	8.37	0.40	9.77	0.49	10.97	0.57	12.03	0.65	<u>13.00</u>	<u>0.72</u>	<u>13.88</u>	<u>0.81</u>
	1400	7.70	0.45	9.27	0.54	10.57	0.63	11.68	0.71	<u>12.70</u>	<u>0.79</u>	<u>13.63</u>	<u>0.88</u>	<u>14.50</u>	<u>0.96</u>
	1600	8.78	0.60	10.20	0.69	11.40	0.79	<u>12.47</u>	<u>0.88</u>	<u>13.43</u>	<u>0.97</u>	<u>14.33</u>	<u>1.05</u>	<u>15.17</u>	<u>1.14</u>
	1800	9.88	0.78	11.17	0.88	12.28	0.98	<u>13.28</u>	<u>1.08</u>	<u>14.20</u>	<u>1.17</u>	<u>15.07</u>	<u>1.25</u>	<u>15.87</u>	<u>1.34</u>
	2000	10.98	0.99	12.15	1.10	<u>13.18</u>	<u>1.20</u>	<u>14.13</u>	<u>1.29</u>	<u>15.02</u>	<u>1.39</u>	<u>15.83</u>	<u>1.48</u>	<u>16.62</u>	<u>1.58</u>
40RUA*12 40RUQ*12 40RUS*12	1420	7.02	0.26	9.86	0.54	11.17	0.67	12.28	0.79	<u>13.29</u>	<u>0.92</u>	<u>14.23</u>	<u>1.05</u>	<u>15.14</u>	<u>1.19</u>
	1650	10.44	0.73	11.06	0.80	12.25	0.96	13.31	1.10	<u>14.25</u>	<u>1.25</u>	<u>15.13</u>	<u>1.39</u>	<u>15.96</u>	<u>1.54</u>
	1890	11.76	1.06	12.31	1.15	13.38	1.32 [†]	14.37	1.49 [†]	<u>15.28</u>	<u>1.66</u>	<u>16.11</u>	<u>1.83</u>	<u>16.89</u>	<u>1.99</u>
	2120	13.10	1.48 [†]	13.59	1.58 [†]	<u>14.55</u>	<u>1.78</u>	<u>15.48</u>	<u>1.97</u>	<u>16.34</u>	<u>2.17</u>	<u>17.14</u>	<u>2.35</u>	<u>17.89</u>	<u>2.54</u>
	2360	14.45	2.01	<u>14.89</u>	<u>2.12</u>	<u>15.76</u>	<u>2.34</u>	<u>16.62</u>	<u>2.56</u>	<u>17.43</u>	<u>2.77</u>	<u>18.20</u>	<u>2.98</u>	<u>18.92</u>	<u>3.19</u>
40RUA*14 40RUS*14	1770	6.84	0.32	7.78	0.41	9.46	0.62	10.82	0.83	12.02	1.05	<u>13.13</u>	<u>1.28</u>	<u>14.19</u>	<u>1.53</u>
	2030	7.58	0.46	8.40	0.55	9.98	0.78	11.31	1.03	<u>12.47</u>	<u>1.27</u>	<u>13.52</u>	<u>1.52</u>	<u>14.51</u>	<u>1.78</u>
	2360	8.57	0.69	9.27	0.79	10.68	1.04	11.96	1.31	<u>13.09</u>	<u>1.60</u>	<u>14.11</u>	<u>1.88</u>	<u>15.05</u>	<u>2.17</u>
	2690	9.59	0.99	10.20	1.10	11.44	1.36	<u>12.64</u>	<u>1.66</u>	<u>13.74</u>	<u>1.98</u>	<u>14.74</u>	<u>2.30</u>	<u>15.65</u>	<u>2.63</u>
	2950	10.40	1.28	10.96	1.39	12.09	1.67	<u>13.21</u>	<u>1.98</u>	<u>14.27</u>	<u>2.33</u>	<u>15.25</u>	<u>2.68</u>	<u>16.15</u>	<u>3.03</u>
40RUA*16 40RUQ*16 40RUS*16	2120	7.28	0.45	8.05	0.54	9.60	0.75	11.00	1.00	<u>12.21</u>	<u>1.26</u>	<u>13.28</u>	<u>1.51</u>	<u>14.27</u>	<u>1.78</u>
	2500	8.32	0.71	8.97	0.80	10.29	1.02	11.59	1.30	<u>12.78</u>	<u>1.59</u>	<u>13.84</u>	<u>1.89</u>	<u>14.80</u>	<u>2.19</u>
	2830	9.25	1.00	9.83	1.10	10.99	1.33	<u>12.16</u>	<u>1.62</u>	<u>13.29</u>	<u>1.93</u>	<u>14.34</u>	<u>2.27</u>	<u>15.30</u>	<u>2.60</u>
	3210	10.33	1.42	10.85	1.54	11.87	1.78	<u>12.90</u>	<u>2.07</u>	<u>13.93</u>	<u>2.40</u>	<u>14.93</u>	<u>2.76</u>	<u>15.87</u>	<u>3.14</u>
	3540	11.29	1.88	11.77	2.01	<u>12.69</u>	<u>2.27</u>	<u>13.62</u>	<u>2.56</u>	<u>14.56</u>	<u>2.90</u>	<u>15.49</u>	<u>3.27</u>	<u>16.40</u>	<u>3.67</u>

40RU

LEGEND

ESP — External Static Pressure

Bold indicates field-supplied drive is required.

Plain type indicates standard motor and standard drive.

Underline indicates a different motor and drive combination other than the standard motor and standard drive combination is required. Refer to fan motor and drive tables to complete selection.

† — For 40RUQ*12, these operating points require different motor and drive combination.

NOTES:

- Maximum allowable fan speed is 20 r/s for all sizes.
- Fan performance is based on deductions for wet coil, clean 51-mm filters, and unit casing. See table at right for factory-supplied filter pressure drop.
- Refer to fan motor and drive tables for additional data.

FACTORY-SUPPLIED PRESSURE DROP — SI

UNIT	AIRFLOW (L/s)	PRESSURE DROP (Pa)
40RUA*07 40RUQ*07	850	13
	1150	20
	1450	28
40RUA*08 40RUQ*08 40RUS*08	1000	17
	1400	27
	1800	38
40RUS*10	1200	21
	1600	33
	2000	46
40RUA*12 40RUQ*12 40RUS*12	1450	28
	1900	42
	2350	56
40RUA*14 40RUS*14	1750	15
	2350	24
	2950	33
40RUA*16 40RUQ*16 40RUS*16	2100	20
	2800	30
	3500	42

**Table 31 – FAN PERFORMANCE DATA — 40RU
350-600 Pa ESP — 60 Hz, SI**

40RU

UNIT	AIRFLOW (L/s)	EXTERNAL STATIC PRESSURE (Pa)											
		350		400		450		500		550		600	
		r/s	kW	r/s	kW	r/s	kW	r/s	kW	r/s	kW	r/s	kW
40RUA*07 40RUQ*07	850	<u>15.34</u>	<u>0.80</u>	<u>16.25</u>	<u>0.92</u>	<u>17.10</u>	<u>1.03</u>	<u>17.90</u>	<u>1.16</u>	<u>18.66</u>	<u>1.28</u>	<u>19.39</u>	<u>1.41</u>
	990	<u>15.69</u>	<u>0.94</u>	<u>16.61</u>	<u>1.07</u>	<u>17.47</u>	<u>1.20</u>	<u>18.28</u>	<u>1.33</u>	<u>19.04</u>	<u>1.47</u>	<u>19.77</u>	<u>1.61</u>
	1130	<u>16.04</u>	<u>1.09</u>	<u>16.95</u>	<u>1.23</u>	<u>17.81</u>	<u>1.38</u>	<u>18.63</u>	<u>1.53</u>	<u>19.40</u>	<u>1.67</u>	—	—
	1270	<u>16.44</u>	<u>1.27</u>	<u>17.32</u>	<u>1.42</u>	<u>18.17</u>	<u>1.58</u>	<u>18.97</u>	<u>1.74</u>	<u>19.75</u>	<u>1.90</u>	—	—
	1420	<u>16.91</u>	<u>1.49</u>	<u>17.75</u>	<u>1.64</u>	<u>18.56</u>	<u>1.81</u>	<u>19.34</u>	<u>1.97</u>	—	—	—	—
40RUA*08 40RUQ*08 40RUS*08	1060	<u>15.50</u>	<u>0.96</u>	<u>16.43</u>	<u>1.10</u>	<u>17.31</u>	<u>1.23</u>	<u>18.14</u>	<u>1.37</u>	<u>18.93</u>	<u>1.51</u>	<u>19.68</u>	<u>1.66</u>
	1230	<u>15.84</u>	<u>1.14</u>	<u>16.75</u>	<u>1.28</u>	<u>17.62</u>	<u>1.43</u>	<u>18.45</u>	<u>1.58</u>	<u>19.24</u>	<u>1.74</u>	—	—
	1420	<u>16.34</u>	<u>1.38</u>	<u>17.19</u>	<u>1.54</u>	<u>18.01</u>	<u>1.70</u>	<u>18.81</u>	<u>1.86</u>	<u>19.59</u>	<u>2.03</u>	—	—
	1600	<u>16.97</u>	<u>1.69</u>	<u>17.76</u>	<u>1.85</u>	<u>18.52</u>	<u>2.02</u>	<u>19.27</u>	<u>2.19</u>	—	—	—	—
	1770	<u>17.61</u>	<u>2.01</u>	<u>18.35</u>	<u>2.18</u>	<u>19.07</u>	<u>2.35</u>	<u>19.77</u>	<u>2.53</u>	—	—	—	—
40RUS*10	1200	<u>14.73</u>	<u>0.88</u>	<u>15.52</u>	<u>0.96</u>	<u>16.25</u>	<u>1.05</u>	<u>16.97</u>	<u>1.12</u>	<u>17.65</u>	<u>1.20</u>	—	—
	1400	<u>15.32</u>	<u>1.05</u>	<u>16.08</u>	<u>1.13</u>	<u>16.82</u>	<u>1.21</u>	<u>17.50</u>	<u>1.29</u>	<u>18.17</u>	<u>1.37</u>	—	—
	1600	<u>15.95</u>	<u>1.23</u>	<u>16.70</u>	<u>1.31</u>	<u>17.40</u>	<u>1.40</u>	<u>18.08</u>	<u>1.48</u>	<u>18.73</u>	<u>1.57</u>	—	—
	1800	<u>16.63</u>	<u>1.43</u>	<u>17.35</u>	<u>1.52</u>	<u>18.03</u>	<u>1.61</u>	<u>18.70</u>	<u>1.70</u>	<u>19.33</u>	<u>1.79</u>	—	—
	2000	<u>17.35</u>	<u>1.67</u>	<u>18.05</u>	<u>1.76</u>	<u>18.72</u>	<u>1.85</u>	<u>19.35</u>	<u>1.94</u>	<u>19.98</u>	<u>2.03</u>	—	—
40RUA*12 40RUQ*12 40RUS*12	1420	<u>16.02</u>	<u>1.33</u>	<u>16.87</u>	<u>1.48</u>	<u>17.71</u>	<u>1.64</u>	<u>18.52</u>	<u>1.80</u>	<u>19.30</u>	<u>1.97</u>	—	—
	1650	<u>16.76</u>	<u>1.70</u>	<u>17.53</u>	<u>1.85</u>	<u>18.29</u>	<u>2.02</u>	<u>19.04</u>	<u>2.19</u>	<u>19.77</u>	<u>2.37</u>	—	—
	1890	<u>17.64</u>	<u>2.16</u>	<u>18.35</u>	<u>2.33</u>	<u>19.05</u>	<u>2.51</u>	<u>19.74</u>	<u>2.69</u>	—	—	—	—
	2120	<u>18.60</u>	<u>2.73</u>	<u>19.28</u>	<u>2.91</u>	<u>19.93</u>	<u>3.10</u>	—	—	—	—	—	—
	2360	<u>19.61</u>	<u>3.40</u>	—	—	—	—	—	—	—	—	—	—
40RUA*14 40RUS*14	1770	<u>15.21</u>	<u>1.78</u>	<u>16.19</u>	<u>2.06</u>	<u>17.15</u>	<u>2.34</u>	<u>18.04</u>	<u>2.64</u>	<u>18.91</u>	<u>2.94</u>	<u>19.75</u>	<u>3.25</u>
	2030	<u>15.46</u>	<u>2.05</u>	<u>16.37</u>	<u>2.33</u>	<u>17.26</u>	<u>2.63</u>	<u>18.12</u>	<u>2.94</u>	<u>18.96</u>	<u>3.26</u>	<u>19.78</u>	<u>3.59</u>
	2360	<u>15.94</u>	<u>2.46</u>	<u>16.78</u>	<u>2.77</u>	<u>17.60</u>	<u>3.08</u>	<u>18.40</u>	<u>3.40</u>	<u>19.18</u>	<u>3.73</u>	<u>19.94</u>	<u>4.07</u>
	2690	<u>16.51</u>	<u>2.95</u>	<u>17.32</u>	<u>3.28</u>	<u>18.09</u>	<u>3.62</u>	<u>18.84</u>	<u>3.96</u>	<u>19.57</u>	<u>4.31</u>	—	—
	2950	<u>16.99</u>	<u>3.39</u>	<u>17.78</u>	<u>3.74</u>	<u>18.54</u>	<u>4.10</u>	<u>19.26</u>	<u>4.47</u>	<u>19.96</u>	<u>4.84</u>	—	—
40RUA*16 40RUQ*16 40RUS*16	2120	<u>15.21</u>	<u>2.05</u>	<u>16.11</u>	<u>2.33</u>	<u>16.98</u>	<u>2.62</u>	<u>17.83</u>	<u>2.93</u>	<u>18.66</u>	<u>3.24</u>	<u>19.47</u>	<u>3.57</u>
	2500	<u>15.69</u>	<u>2.49</u>	<u>16.54</u>	<u>2.80</u>	<u>17.35</u>	<u>3.12</u>	<u>18.14</u>	<u>3.44</u>	<u>18.90</u>	<u>3.77</u>	<u>19.64</u>	<u>4.11</u>
	2830	<u>16.18</u>	<u>2.94</u>	<u>17.01</u>	<u>3.28</u>	<u>17.79</u>	<u>3.63</u>	<u>18.54</u>	<u>3.97</u>	<u>19.27</u>	<u>4.33</u>	<u>19.97</u>	<u>4.69</u>
	3210	<u>16.75</u>	<u>3.52</u>	<u>17.57</u>	<u>3.90</u>	<u>18.34</u>	<u>4.29</u>	<u>19.08</u>	<u>4.67</u>	<u>19.78</u>	<u>5.06</u>	—	—
	3540	<u>17.26</u>	<u>4.09</u>	<u>18.07</u>	<u>4.50</u>	<u>18.84</u>	<u>4.93</u>	<u>19.57</u>	<u>5.35</u>	—	—	—	—

LEGEND

ESP — External Static Pressure

Bold indicates field-supplied drive is required.

Plain type indicates standard motor and standard drive.

Underline indicates a different motor and drive combination other than the standard motor and standard drive combination is required. Refer to fan motor and drive tables to complete selection.

NOTES:

1. Maximum allowable fan speed is 20 r/s for all sizes.
2. Fan performance is based on deductions for wet coil, clean 51-mm filters, and unit casing. See table at right for factory-supplied filter pressure drop.
3. Refer to fan motor and drive tables for additional data.

FACTORY-SUPPLIED PRESSURE DROP — SI

UNIT	AIRFLOW (L/s)	PRESSURE DROP (Pa)
40RUA*07 40RUQ*07	850	13
	1150	20
	1450	28
40RUA*08 40RUQ*08 40RUS*08	1000	17
	1400	27
	1800	38
40RUS*10	1200	21
	1600	33
	2000	46
40RUA*12 40RUQ*12 40RUS*12	1450	28
	1900	42
	2350	56
40RUA*14 40RUS*14	1750	15
	2350	24
	2950	33
40RUA*16 40RUQ*16 40RUS*16	2100	20
	2800	30
	3500	42

START-UP CHECKLIST
(SPLIT SYSTEMS WITH 40RU UNITS)

I. PRELIMINARY INFORMATION

OUTDOOR: MODEL NO. _____ INDOOR: MODEL NO. _____
SERIAL NO. _____ SERIAL NO. _____
ADDITIONAL ACCESSORIES _____

II. PRE-START-UP

OUTDOOR UNIT

IS THERE ANY SHIPPING DAMAGE? (Y/N) _____
IF SO, WHERE: _____

WILL THIS DAMAGE PREVENT UNIT START-UP? (Y/N) _____
CHECK POWER SUPPLY. DOES IT AGREE WITH UNIT? (Y/N) _____
HAS THE GROUND WIRE BEEN CONNECTED? (Y/N) _____
HAS THE CIRCUIT PROTECTION BEEN SIZED AND INSTALLED PROPERLY? (Y/N) _____
ARE THE POWER WIRES TO THE UNIT SIZED AND INSTALLED PROPERLY? (Y/N) _____
HAVE COMPRESSOR HOLDDOWN BOLTS BEEN LOOSENED? (Y/N) _____

CONTROLS

ARE THERMOSTAT(S) & INDOOR FAN CONTROL WIRING CONNECTIONS MADE & CHECKED? (Y/N) _____
ARE ALL WIRING TERMINALS (including main power supply) TIGHT? (Y/N) _____
HAVE OUTDOOR UNIT CRANKCASE HEATERS BEEN ENERGIZED FOR 24 HOURS? (Y/N) _____

INDOOR UNIT

HAS WATER BEEN PLACED IN DRAIN PAN TO CONFIRM PROPER DRAINAGE? (Y/N) _____
ARE PROPER AIR FILTERS IN PLACE? (Y/N) _____
HAVE FAN AND MOTOR PULLEYS BEEN CHECKED FOR PROPER ALIGNMENT? (Y/N) _____
DO THE FAN BELTS HAVE PROPER TENSION? (Y/N) _____

PIPING

40RUA, 40RUQ

HAS FOAM SHIPPING BLOCK BEEN REMOVED FROM THE TXV (Thermostatic Expansion Valve)? (Y/N) _____
ARE LIQUID LINE SOLENOID VALVES LOCATED AT THE INDOOR UNIT (40RUA) OR OUTDOOR UNIT (40RUQ) COILS AS REQUIRED? (Y/N) _____
HAVE LEAK CHECKS BEEN MADE AT COMPRESSORS, CONDENSERS, INDOOR COILS, TXVs (Thermostatic Expansion Valves) SOLENOID VALVES, FILTER DRIERS, AND FUSIBLE PLUGS WITH A LEAK DETECTOR? (Y/N) _____
LOCATE, REPAIR, AND REPORT ANY LEAKS _____
HAVE ALL COMPRESSOR SERVICE VALVES BEEN FULLY OPENED (BACKSEATED) (Y/N) _____
ARE THE COMPRESSOR OIL SIGHT GLASSES SHOWING CORRECT LEVELS? (Y/N) _____

40RUS

HAS AIR BEEN BLED FROM SYSTEM? (Y/N) _____
HAVE LEAK CHECKS BEEN MADE AT COMPRESSORS, CHILLERS, VALVES, & INDOOR COILS? (Y/N) _____
LOCATE, REPAIR, AND REPORT ANY LEAKS. _____

40RU

CHECK VOLTAGE IMBALANCE

LINE-TO-LINE VOLTS: AB _____ V AC _____ V BC _____ V

(AB + AC + BC)/3 = AVERAGE VOLTAGE = _____ V

MAXIMUM DEVIATION FROM AVERAGE VOLTAGE = _____ V

VOLTAGE IMBALANCE = 100 X (MAX DEVIATION)/(AVERAGE VOLTAGE) = _____

IF OVER 2% VOLTAGE IMBALANCE, DO NOT ATTEMPT TO START SYSTEM!
CALL LOCAL POWER COMPANY FOR ASSISTANCE.

III. START-UP

CHECK INDOOR FAN MOTOR SPEED AND RECORD.

AFTER AT LEAST 10 MINUTES RUNNING TIME, RECORD THE FOLLOWING MEASUREMENTS:

40RU

	COMP A1	COMP B1
OIL PRESSURE	_____	_____
SUCTION PRESSURE	_____	_____
SUCTION LINE TEMP	_____	_____
DISCHARGE PRESSURE	_____	_____
DISCHARGE LINE TEMP	_____	_____
ENTERING OUTDOOR UNIT AIR TEMP	_____	_____
LEAVING OUTDOOR UNIT AIR TEMP	_____	_____
INDOOR UNIT ENTERING AIR DB TEMP	_____	_____
INDOOR UNIT ENTERING AIR WB TEMP	_____	_____
INDOOR UNIT LEAVING AIR DB TEMP	_____	_____
INDOOR UNIT LEAVING AIR WB TEMP	_____	_____
OUTDOOR UNIT ENTERING WATER TEMP (40RUS ONLY)	_____	_____
OUTDOOR UNIT LEAVING WATER TEMP (40RUS ONLY)	_____	_____
INDOOR UNIT ENTERING WATER TEMP (40RUS ONLY)	_____	_____
INTDOOR UNIT LEAVING WATER TEMP (40RUS ONLY)	_____	_____
COMPRESSOR AMPS (L1/L2/L3)	___/___/___	___/___/___

CHECK THE COMPRESSOR OIL LEVEL SIGHT GLASSES, ARE THE SIGHT GLASSES SHOWING OIL LEVEL AT 1/8 to 1/3 FULL? (Y/N) _____

NOTES:

TAB 3

WARRANTY



turn to the experts 

Limited Warranty for Air Conditioner & Heat Pump Condensing Units with Puron® (R-410A) Refrigerant

FOR WARRANTY SERVICE OR REPAIR:

Contact the installer or a Carrier dealer. You may be able to find the installer's name on the equipment or in your Owner's Packet. You can also find a Carrier dealer online at www.carrier.com

For help, contact: Carrier Corporation, Consumer Relations, P.O. Box 4808, Syracuse, New York 13221, Phone 1-800-227-7437

PRODUCT REGISTRATION: You can register your product online at www.carrier.com.

Model Number _____ Serial Number _____

Date of Installation _____ Installed by _____

Name of Owner _____ Address of Installation _____

Carrier Corporation (hereinafter "Company") warrants this product against failure due to defect in materials or workmanship under normal use and maintenance as follows. All warranty periods begin on the date of original installation. If a part fails due to defect during the applicable warranty period Company will provide a new or remanufactured part, at Company's option, to replace the failed defective part at no charge for the part. Alternatively, and at its option, the Company will provide a credit in the amount of the then factory selling price for a new equivalent part toward the retail purchase price of a new Company product. Except as otherwise stated herein, those are Company's exclusive obligations under this warranty for a product failure. This limited warranty is subject to all provisions, conditions, limitations and exclusions listed below and on the reverse (if any) of this document.

RESIDENTIAL APPLICATIONS

This warranty is to the original purchasing owner and subsequent owners only to the extent and as stated in the Warranty Conditions and below. The limited warranty period in years, depending on the part and the claimant, is as shown in the table below.

Product	Item	Limited Warranty (Years)	
		Original Owner	Subsequent Owners
Air Conditioner or Heat Pump Condensing Unit	Parts	10* (or 5)	5
	Compressor	10* (or 5)	5

* If properly registered within 90 days of original installation, otherwise 5 years (except in California and Quebec and other jurisdictions that prohibit warranty benefits conditioned on registration). See Warranty Conditions below.

OTHER APPLICATIONS

The warranty period is five (5) years on the compressor, and one (1) year on all other parts. The warranty is to the original owner only and is not available for subsequent owners.

LEGAL REMEDIES - The owner **must** notify the Company in writing, by certified or registered letter to Carrier Corporation, Warranty Claims, P.O. Box 4808, Syracuse, New York 13221, of any defect or complaint with the product, stating the defect or complaint and a specific request for repair, replacement, or other correction of the product under warranty, mailed at least thirty (30) days before pursuing any legal rights or remedies.





turn to the experts 

WARRANTY CONDITIONS:

1. To obtain the longer warranty periods as shown in the table under original owner, the product must be properly registered at www.carrier.com within ninety (90) days of original installation. In jurisdictions where warranty benefits conditioned on registration are prohibited by law, registration is not required and the longer warranty period shown will apply.
2. Where a product is installed in a newly constructed home, the date of installation is the date the homeowner purchased the home from the builder.
3. If the date of original installation cannot be verified, then the warranty period begins ninety (90) days from the date of product manufacture (as indicated by the model and serial number). Proof of purchase may be required at time of service.
4. The limited parts warranty periods as shown in the table under Subsequent Owners do not require registration.
5. Product must be installed properly and by a licensed HVAC technician.
6. The warranty applies only to products remaining in their original installation location.
7. Installation, use, care, and maintenance must be normal and in accordance with instructions contained in the Installation Instructions, Owner's Manual and Company's service information.
8. Defective parts must be returned to the distributor through a registered servicing dealer for credit.

LIMITATIONS OF WARRANTIES: ALL IMPLIED WARRANTIES AND/OR CONDITIONS (INCLUDING IMPLIED WARRANTIES OR CONDITIONS OF MERCHANTABILITY AND FITNESS FOR A PARTICULAR USE OR PURPOSE) ARE LIMITED TO THE DURATION OF THIS LIMITED WARRANTY. SOME STATES OR PROVINCES DO NOT ALLOW LIMITATIONS ON HOW LONG AN IMPLIED WARRANTY OR CONDITION LASTS, SO THE ABOVE MAY NOT APPLY TO YOU. THE EXPRESS WARRANTIES MADE IN THIS WARRANTY ARE EXCLUSIVE AND MAY NOT BE ALTERED, ENLARGED, OR CHANGED BY ANY DISTRIBUTOR, DEALER, OR OTHER PERSON, WHATSOEVER.

THIS WARRANTY DOES NOT COVER:

1. Labor or other costs incurred for diagnosing, repairing, removing, installing, shipping, servicing or handling of either defective parts, or replacement parts, or new units.
2. Any product not installed pursuant to applicable regional efficiency standards issued by the Department of Energy.
3. Any product purchased over the Internet.
4. Normal maintenance as outlined in the installation and servicing instructions or Owner's Manual, including filter cleaning and/or replacement and lubrication.
5. Failure, damage or repairs due to faulty installation, misapplication, abuse, improper servicing, unauthorized alteration or improper operation.
6. Failure to start or damages due to voltage conditions, blown fuses, open circuit breakers, or the inadequacy, unavailability, or interruption of electrical, Internet service provider, or mobile device carrier service or your home network.
7. Failure or damage due to floods, winds, fires, lightning, accidents, corrosive environments (rust, etc) or other conditions beyond the control of Company.
8. Parts not supplied or designated by Company, or damages resulting from their use.
9. Products installed outside the U.S.A. or Canada.
10. Electricity or fuel costs, or increases in electricity or fuel costs from any reason whatsoever, including additional or unusual use of supplemental electric heat.
11. Any cost to replace, refill or dispose of refrigerant, including the cost of refrigerant.
12. **ANY SPECIAL, INDIRECT OR CONSEQUENTIAL PROPERTY OR COMMERCIAL DAMAGE OF ANY NATURE WHATSOEVER.** Some states or provinces do not allow the exclusion of incidental or consequential damages, so the above limitation may not apply to you.

This Warranty gives you specific legal rights, and you may also have other rights which vary from state to state or province to province.



TAB 4

START-UP FORMS

START UP CHECKLIST

I. PRELIMINARY INFORMATION

OUTDOOR: MODEL NO. _____ SERIAL NO. _____

INDOOR: MODEL NO. _____ SERIAL NO. _____

ADDITIONAL ACCESSORIES _____

II. PRE-START-UP

OUTDOOR UNIT

IS THERE ANY SHIPPING DAMAGE? (Y/N) _____

IF SO, WHERE: _____

WILL THIS DAMAGE PREVENT UNIT START-UP? (Y/N) _____

CHECK POWER SUPPLY. DOES IT AGREE WITH UNIT? (Y/N) _____

HAS THE GROUND WIRE BEEN CONNECTED? (Y/N) _____

HAS THE CIRCUIT PROTECTION BEEN SIZED AND INSTALLED PROPERLY? (Y/N) _____

ARE THE POWER WIRES TO THE UNIT SIZED AND INSTALLED PROPERLY? (Y/N) _____

CONTROLS

ARE THERMOSTAT AND INDOOR FAN CONTROL WIRING CONNECTIONS MADE AND CHECKED?
(Y/N) _____

ARE ALL WIRING TERMINALS (including main power supply) TIGHT? (Y/N) _____

HAS CRANKCASE HEATER BEEN ENERGIZED FOR 24 HOURS? (Y/N) _____

INDOOR UNIT

HAS WATER BEEN PLACED IN DRAIN PAN TO CONFIRM PROPER DRAINAGE? (Y/N) _____

ARE PROPER AIR FILTERS IN PLACE? (Y/N) _____

HAVE FAN AND MOTOR PULLEYS BEEN CHECKED FOR PROPER ALIGNMENT? (Y/N) _____

DO THE FAN BELTS HAVE PROPER TENSION? (Y/N) _____

HAS CORRECT FAN ROTATION BEEN CONFIRMED? (Y/N) _____

PIPING

IS LIQUID LINE SOLENOID VALVE LOCATED AT THE OUTDOOR COILS AS REQUIRED? (Y/N) _____

HAVE LEAK CHECKS BEEN MADE AT COMPRESSOR, OUTDOOR AND INDOOR COILS, TXVs (Thermostatic Expansion Valves), SOLENOID VALVES, FILTER DRIERS, AND FUSIBLE PLUGS WITH A LEAK DETECTOR? (Y/N) _____

LOCATE, REPAIR, AND REPORT ANY LEAKS. _____

HAS LIQUID LINE SERVICE VALVE BEEN OPENED? (Y/N) _____

HAS VAPOR LINE SERVICE VALVE BEEN OPENED? (Y/N) _____

38AUG

CHECK VOLTAGE IMBALANCE

LINE-TO-LINE VOLTS: AB _____ V AC _____ V BC _____ V

$(AB + AC + BC)/3 = \text{AVERAGE VOLTAGE} = \underline{\hspace{2cm}}$ V

MAXIMUM DEVIATION FROM AVERAGE VOLTAGE = _____ V

VOLTAGE IMBALANCE = $100 \times (\text{MAX DEVIATION})/(\text{AVERAGE VOLTAGE}) = \underline{\hspace{2cm}}$

IF OVER 2% VOLTAGE IMBALANCE, DO NOT ATTEMPT TO START SYSTEM!
CALL LOCAL POWER COMPANY FOR ASSISTANCE.

CHECK INDOOR UNIT FAN SPEED AND RECORD. _____

CHECK OUTDOOR UNIT FAN SPEED AND RECORD. _____

AFTER AT LEAST 10 MINUTES RUNNING TIME, RECORD THE FOLLOWING MEASUREMENTS:

	COOLING	HEATING
VAPOR PRESSURE	_____	_____
SUCTION LINE TEMP	_____	_____ (AT COMPRESSOR)
LIQUID PRESSURE	_____	_____
LIQUID LINE TEMP	_____	_____
ENTERING OUTDOOR UNIT AIR TEMP	_____	_____
LEAVING OUTDOOR UNIT AIR TEMP	_____	_____
INDOOR UNIT ENTERING-AIR DB (dry bulb) TEMP	_____	_____
INDOOR UNIT ENTERING-AIR WB (wet bulb) TEMP	_____	_____
INDOOR UNIT LEAVING-AIR DB TEMP	_____	_____
INDOOR UNIT LEAVING-AIR wB TEMP	_____	_____
COMPRESSOR 1 AMPS (L1/L2/L3)	_____ / _____ / _____	
COMPRESSOR 2 AMPS (L1/L2/L3)	_____ / _____ / _____	

NOTES:

38AUQ