



Western Water Constructors, Inc.
Submittal Cover

Job no. 16-05



CONTRACT NAME: Manteca WQCF Digester Improvements
SPEC SECTION: 15115 Gate, Globe, and Angle Valves
SUBMITTAL TITLE: Knife Gate Valves - O&M
FILE NAME: 224-R0_15115-04_Knife Gate Valves-OM

SUB #: 224
REV #: 0
CODE: 15115-04
DATE: 11/22/2017

WWC REVIEW/COMMENTS: [X] NO EXCEPTIONS [] EXCEPTIONS / DEVIATIONS AS NOTED

REVIEWED BY: ST

SIGNED: [Signature]

WWC HAS REVIEWED THIS SUBMITTAL FOR CONFORMANCE WITH THE PROJECT PLANS & SPECIFICATIONS.

OWNER REVIEW:

Table with columns: ITEM, DESCRIPTION, REVIEW STATUS (A, B, C, D, E). Row 1: 1, Knife Gate Valves O&M, [] [] [] [] []

LEGEND: A = No Exceptions Taken B = Make Correction Noted C = Correct & Resubmit
D = Rejected E = Accepted for Record

OWNER COMMENTS:

REVIEWER'S NAME: _____

REVIEWER'S SIGNATURE: _____ DATE: _____

EQUIPMENT SUMMARY FORM

1. EQUIPMENT ITEM Knife gate valve
2. MANUFACTURER DeZurik
3. EQUIPMENT IDENTIFICATION NUMBER(S) _____
(maps equipment number)
4. LOCATION OF EQUIPMENT _____
5. WEIGHT OF INDIVIDUAL COMPONENTS (OVER 100 POUNDS) _____

6. NAMEPLATE DATA - Horsepower _____
Amperage _____
Voltage _____
Service Factor (S.F.) _____
Speed _____
ENC Type _____
Capacity _____
Other _____
7. MANUFACTURER'S LOCAL REPRESENTATIVE
Name Frank A Olsen Co
Address 286 Rickenbacker Cir, Livermore, CA 94551
Telephone Number (925) 961-8888
8. MAINTENANCE REQUIREMENTS _____

9. LUBRICANT LIST _____

10. SPARE PARTS (recommendations) _____

11. COMMENTS _____



DeZURIK

2-24" (50-600mm)

KGN-RSB

**BI-DIRECTIONAL CAST
STAINLESS STEEL
KNIFE GATE VALVES**

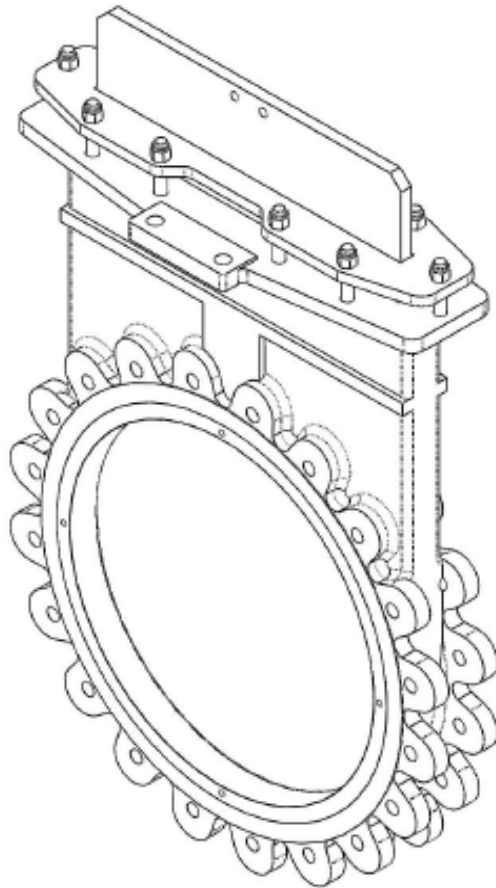

Instruction D11023
October 2016

DeZURIK

2-24" (50-600MM) KGN-RSB BI-DIRECTIONAL CAST STAINLESS STEEL KNIFE GATE VALVE

Instructions

These instructions provide information about KGN-RSB Knife Gate Valves. They are for use by personnel who are responsible for the installation, operation and maintenance of your KGN-RSB Knife Gate Valve.

Safety Messages

All safety messages in the instructions are flagged with the word Caution, Warning or Danger. These messages must be followed exactly to avoid equipment damage, personal injury or death.

Safety label(s) on the product indicate hazards that can cause equipment damage, personal injury or death. If a safety label becomes difficult to see, or if a label has been removed, please contact DeZURIK for replacement.



WARNING!

Personnel involved in the installation or maintenance of valves should be constantly alert to potential emission of process material and take appropriate safety precautions. Always wear suitable protection when dealing with hazardous process materials. Handle valves which have been removed from service with the assumption of process material within the valve.

Inspection

Your KGN-RSB Knife Gate Valve has been packaged to provide protection during shipment; however, it can be damaged in transport. Carefully inspect the unit for damage upon arrival and file a claim with the carrier if damage is apparent.

Parts

Recommended spare parts are listed on the assembly drawing. These parts should be stocked to minimize downtime.

Order parts from your DeZURIK sales representative, or directly from DeZURIK. When ordering parts, please include the 7-digit part number and 4-digit revision number (example: **9999999R000**) located on the data plate attached to the valve assembly. Also include the part name, the assembly drawing number, the balloon number and the quantity stated on the assembly drawing.

DeZURIK Service

DeZURIK Service personnel are available to install, maintain and repair all DeZURIK products. DeZURIK also offers customized training programs and consultation services.

For more information, contact your local DeZURIK representative or visit our website at www.dezurik.com.

Table of Contents

Description	3
Installation	3
Operation	3
Lubrication	3
Packing	3
Adjustment	3
Drawings	4
Replacement of Resilient Seat	5
Packing Replacement	6
<i>Removing the Old Packing</i>	6
<i>Installing the New Packing</i>	6
<i>Reassembling the Valve</i>	6
Troubleshooting	7

Description

The KGN-RSB is a bi-directional cast stainless steel, perimeter sealed knife gate valve. A choice of several actuators and accessories is available.

Installation

Failure to install the valve properly can result in damage to the valve gate.

Install the valve to the mating pipe flange using proper size bolts. It is very important to choose the proper length of bolt for the bolt holes in the chest of the valve. These holes are bottom drilled and tapped holes.

Be careful not to bottom out bolts in the chest during installation. Table A gives recommended bolt torques to be used during installation, however, depending on the type of gaskets being used the required torques may be higher or lower. Use the cross torque pattern method for tightening the bolts. Mating flanges must be parallel and true with each other and the valve. Do not use the valve to pull together mating pipes.

After installation, open and close the valve once to assure smooth operation.

Operation

The gate in the valve is positioned by the valve actuator. The actuator moves the gate over the valve port in the closed position, and withdraws the gate from the seat in the throttling and open positions. Refer to the Actuator Instructions for adjustment and maintenance requirements for the actuator.

Lubrication

The valve does not require lubrication. If applicable, ensure that valve threaded stems are maintained with proper lubrication. Refer to the Actuator Instructions for lubrication requirements for the actuator.

Packing

The gate packing is contained and compressed by the packing gland. See Figure 1 for component identification.

Adjustment

If packing leaks, tighten the adjustment nuts on top of the packing gland. Tighten the nuts evenly and gently — just enough to stop the leak. Over tightening will cause excessive operating forces, and will decrease the life of the packing.

Table A: Recommended Flange Bolt/Stud Torque Range in ft-lbs (non-lubricated)

Valve Size	ASME Gasket Types	
	Rubber with Soft Fabric Filler, & 1/8" Thick Hard	Soft Elastomer Gasket Shore Durometer < 75A
2" (50mm)	26 - 29	8 - 9
3" (80mm)	37 - 41	14 - 16
4" (100mm)	26 - 29	11 - 12
6" (150mm)	41 - 45	22 - 24
8" (200mm)	55 - 61	35 - 39
10" (250mm)	56 - 62	40 - 44
12" (300mm)	80 - 88	59 - 65
14" (350mm)	107 - 118	81 - 89
16" (400mm)	103 - 114	79 - 87
18" (450mm)	128 - 141	102 - 112
20" (500mm)	123 - 136	99 - 109
24" (600mm)	188 - 207	155 - 171
30" (750mm)	198 - 218	168 - 185
36" (900mm)	289 - 318	248 - 273

Note: Torque ranges are based on ASME Pressure Vessel Code Calculations and lab test data. These torques are only for the listed gasket types. For other gasket types listed in ASME, consult DeZURIK.

Drawings

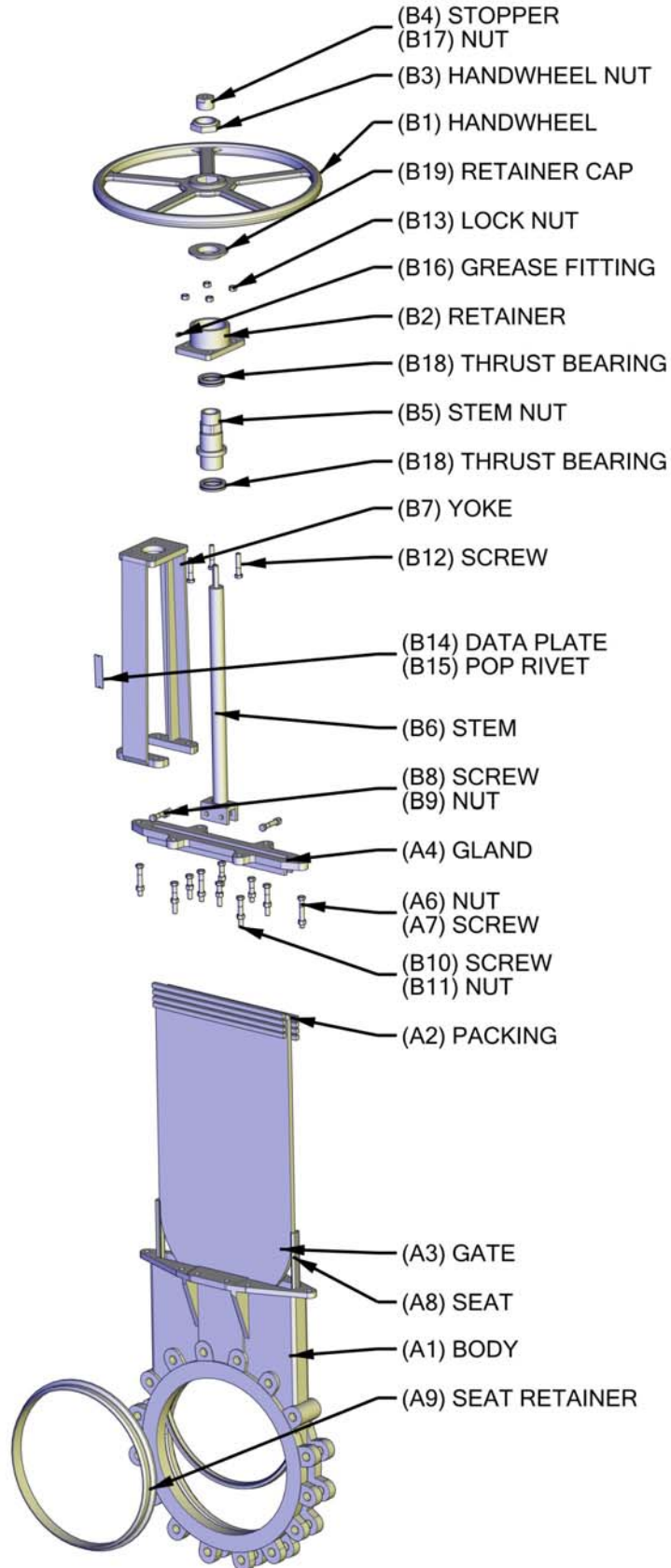

Figure 1: Component Identification

Replacement of Resilient Seat



WARNING!

Pipeline pressure can cause personal injury or equipment damage. Relieve pipeline pressure before removing gate stem and packing gland nuts.

1. Relieve the pressure in the pipeline and close the valve.
-



WARNING!

Accidental operation of power actuator can cause personal injury or equipment damage. Disconnect and lock out power to actuator before servicing.

2. If the actuator is powered, disconnect and lock out power to prevent accidental operation of the actuator.
3. Remove valve from pipeline.
4. Remove the two screws and nuts near the top of the gate and disengage the stem from the gate by stroking the actuator (not the valve) to the open position.
5. Remove actuator yoke and actuator from valve.
6. Remove the gland nuts, bolts and packing gland.
7. Remove the used packing from the packing chamber.
8. Remove the gate from the body. Inspect and replace galled or damaged gate as needed.
9. Remove valve seat retainer from valve body, as follows:
 - a. Insert two pins into pin holes on retainer,
 - b. Loosen retainer with bar inserting between two pins.
 - c. Remove old seat by pulling the resilient seat out of the valve body.
10. Install new resilient seat:
 - a. Clean the seat cavity in the valve body.
 - b. Insert new resilient seat into valve body seat cavity.
 - c. Trim off excess seat.
11. Assembly of valve:
 - a. Install seat retainer.
 - b. Install knife gate.
 - c. Install new packaging (see page 6).
 - d. Reassemble valve (see page 6).

Packing Replacement

Removing the Old Packing

**WARNING!**

Pipeline pressure can cause personal injury or equipment damage. Relieve pipeline pressure before removing gate stem and packing gland nuts.

1. Relieve the pressure in the pipeline and close the valve.

**WARNING!**

Accidental operation of power actuator can cause personal injury or equipment damage. Disconnect and lock out power to actuator before servicing.

2. If the actuator is powered, disconnect and lock out power to prevent accidental operation of the actuator.
3. Remove the two screws and nuts near the top of the gate and disengage the stem from the gate by stroking the actuator (not the valve) to the open position.
4. Remove the gland nuts, bolts and packing gland.
5. Remove the used packing from the packing chamber.

Installing the New Packing

Packing strip length and quantity are shown in Table 2. Ensure the inside and outside edges of each strip are packed against the gate and packing chamber, so that each strip is compressed flat and evenly.

Do not compress the packing any more than needed to stop leaks.

1. Ensure the gate is fully closed and centered in the body before packing.
2. Assemble and pack the strips one at a time.

Note: DO NOT USE SHARP TOOLS TO PACK THE STRIPS.

Reassembling Valve

1. Replace the packing gland, bolts and nuts. Tighten the nuts evenly and finger tight, plus 1/2 turn.
2. Reconnect the stem to the gate with the two screws and nuts.

TABLE 2: KGN-RSB PACKING SIZE

Valve Size	Packing Size [in]	Packing Length per Layer		# of Layers
		[in]	[mm]	
2" 50mm	3/8"	3.46	87.9	4x2
3" 80mm	3/8"	4.41	112.0	4x2
4" 100mm	3/8"	5.59	142.0	4x2
6" 150mm	3/8"	7.87	199.9	4x2
8" 200mm	3/8"	9.65	245.1	4x2
10" 250mm	3/8"	12.60	320.0	4x2
12" 300mm	1/2"	14.57	370.1	4x2
14" 350mm	1/2"	16.22	412.0	4x2
16" 400mm	1/2"	17.87	453.9	4x2
18" 450mm	1/2"	19.52	495.8	4x2
20" 500mm	1/2"	21.81	554.0	4x2
24" 600mm	1/2"	25.98	659.9	4x2

Note: There are two lengths of packing per layer (one on each side of the gate)

Reassembling Valve continued

4. Pressurize the pipeline and inspect packing for leakage.
5. If packing leaks, tighten the adjustment nuts on top of the packing gland. Tighten the nuts evenly and gently - just enough to stop the leak. Over tightening will cause excessive operating forces, and will decrease the life of the packing.

Troubleshooting

Condition	Possible Causes	Corrective Action
Packing leaks, with no evidence of galling on gate	Packing is loose	Adjust packing gland
	Packing is worn or torn	Replace packing
Packing leaks and gate is galled	Packing is worn or torn	Replace packing and gate, check seat for damage
Valve leaks when fully closed, with no evidence of galling on gate	Seat is worn or torn	Replace seat
Valve leaks when fully closed and gate is galled	Seat is worn or torn	Replace gate and seat

Guarantee

Products, auxiliaries and parts thereof of DeZURIK, Inc. manufacture are warranted to the original purchaser for a period of twenty-four (24) months from date of shipment from factory, against defective workmanship and material, but only if properly installed, operated and serviced in accordance with DeZURIK, Inc. recommendations. Repair or replacement, at our option, for items of DeZURIK, Inc. manufacture will be made free of charge, (FOB) our facility with removal, transportation and installation at your cost, if proved to be defective within such time, and this is your sole remedy with respect to such products. Equipment or parts manufactured by others but furnished by DeZURIK, Inc. will be repaired or replaced, but only to the extent provided in and honored by the original manufacturers warranty to DeZURIK, Inc., in each case subject to the limitations contained therein. No claim for transportation, labor or special or consequential damages or any other loss, cost or damage shall be allowed. You shall be solely responsible for determining suitability for use and in no event shall DeZURIK, Inc. be liable in this respect. DeZURIK, Inc. does not guarantee resistance to corrosion, erosion, abrasion or other sources of failure, nor does DeZURIK, Inc. guarantee a minimum length of service. Your failure to give written notice to us of any alleged defect under this warranty within twenty (20) days of its discovery, or attempts by someone other than DeZURIK, Inc. or its authorized representatives to remedy the alleged defects therein, or failure to return product or parts for repair or replacement as herein provided, or failure to install and operate said products and parts according to instructions furnished by DeZURIK, Inc., or misuse, modification, abuse or alteration of such product, accident, fire, flood or other Act of God, or failure to pay entire contract price when due shall be a waiver by you of all rights under this warranty.

The foregoing guarantee shall be null and void if, after shipment from our factory, the item is modified in any way or a component of another manufacturer, such as but not limited to, an actuator is attached to the item by anyone other than DeZURIK, Inc. Factory Service personnel. All orders accepted shall be deemed accepted subject to this limited warranty, which shall be exclusive of any other or previous Warranty, and this shall be the only effective guarantee or warranty binding on DeZURIK, Inc., despite anything to the contrary contained in the purchase order or represented by any agent or employee of DeZURIK, Inc., in writing or otherwise, notwithstanding, including but not limited to implied warranties.

THE FOREGOING REPAIR AND REPLACEMENT OBLIGATIONS ARE IN LIEU OF ALL OTHER WARRANTIES, OBLIGATIONS AND LIABILITIES, INCLUDING ALL WARRANTIES OF FITNESS FOR A PARTICULAR PURPOSE OR OF MERCHANTABILITY OR OTHERWISE, EXPRESSED OR IMPLIED IN FACT OR BY LAW, AND STATE DEZURIK, INC.'S ENTIRE AND EXCLUSIVE LIABILITY AND YOUR EXCLUSIVE REMEDY FOR ANY CLAIM IN CONNECTION WITH THE SALE AND FURNISHING OF SERVICES, GOODS OR PARTS, THEIR DESIGN, SUITABILITY FOR USE, INSTALLATION OR OPERATIONS.

Limitation of liability

LIMITATION OF LIABILITY: IN NO EVENT SHALL DEZURIK, INC. BE LIABLE FOR ANY DIRECT, INDIRECT, SPECIAL OR CONSEQUENTIAL DAMAGES WHATSOEVER, AND DEZURIK, INC.'S LIABILITY, UNDER NO CIRCUMSTANCES, WILL EXCEED THE CONTRACT PRICE FOR THE GOODS AND/OR SERVICES FOR WHICH LIABILITY IS CLAIMED. ANY ACTION BY YOU FOR BREACH OF CONTRACT MUST BE COMMENCED WITHIN 12 MONTHS AFTER THE DATE OF SALE.



Sales and Service

For information about our worldwide locations, approvals, certifications and local representative:

Web site: www.dezurik.com E-Mail: info@dezurik.com

250 Riverside Ave. N., Sartell, MN 56377 • Phone: 320-259-2000 • Fax: 320-259-2227

DeZURIK, Inc. reserves the right to incorporate our latest design and material changes without notice or obligation. Design features, materials of construction and dimensional data, as described in this manual, are provided for your information only and should not be relied upon unless confirmed in writing by DeZURIK, Inc. Certified drawings are available upon request.

Printed in CANADA