



Western Water Constructors, Inc.
Submittal Cover

Job no. 16-05



CONTRACT NAME: Manteca WQCF Digester Improvements
SPEC SECTION: 15117 Specialty Valves
SUBMITTAL TITLE: Elastomeric Check Valves - O&M
FILE NAME: 218-R1\_15117-05\_Elastomeric Check Valves-OM

SUB #: 218
REV #: 1
CODE: 15117-05
DATE: 12/5/2017

WWC REVIEW/COMMENTS: [X] NO EXCEPTIONS [ ] EXCEPTIONS / DEVIATIONS AS NOTED

Responses to comments:

- 1. Equipment summary form corrected. Valve ID # is FOG-VAL-07-703
2. One 8" Tideflex TF-2 Check Valve will be supplied on the overflow at the FOG Tank.

REVIEWED BY: ST

SIGNED: [Signature]

WWC HAS REVIEWED THIS SUBMITTAL FOR CONFORMANCE WITH THE PROJECT PLANS & SPECIFICATIONS.

OWNER REVIEW:

Table with columns: ITEM, DESCRIPTION, REVIEW STATUS (A, B, C, D, E). Row 1: 1, Elastomeric Check Valves O&M, [ ] [ ] [ ] [ ] [ ]

LEGEND: A = No Exceptions Taken B = Make Correction Noted C = Correct & Resubmit
D = Rejected E = Accepted for Record

OWNER COMMENTS:

REVIEWER'S NAME: \_\_\_\_\_

REVIEWER'S SIGNATURE: \_\_\_\_\_

DATE: \_\_\_\_\_

EQUIPMENT SUMMARY FORM

1. EQUIPMENT ITEM Elastomeric check valve
2. MANUFACTURER Tidflex / Redvalve
3. EQUIPMENT IDENTIFICATION NUMBER(S) FOG-VAL-07-703  
(maps equipment number)
4. LOCATION OF EQUIPMENT \_\_\_\_\_
5. WEIGHT OF INDIVIDUAL COMPONENTS (OVER 100 POUNDS) \_\_\_\_\_  
\_\_\_\_\_  
\_\_\_\_\_
6. NAMEPLATE DATA - Horsepower \_\_\_\_\_  
Amperage \_\_\_\_\_  
Voltage \_\_\_\_\_  
Service Factor (S.F.) \_\_\_\_\_  
Speed \_\_\_\_\_  
ENC Type \_\_\_\_\_  
Capacity \_\_\_\_\_  
Other \_\_\_\_\_
7. MANUFACTURER'S LOCAL REPRESENTATIVE  
Name Gene Ford Company  
Address P.O. Box 1031 San Mateo, CA 9440  
Telephone Number 650-349-1434
8. MAINTENANCE REQUIREMENTS \_\_\_\_\_  
\_\_\_\_\_  
\_\_\_\_\_
9. LUBRICANT LIST \_\_\_\_\_  
\_\_\_\_\_
10. SPARE PARTS (recommendations) \_\_\_\_\_  
\_\_\_\_\_
11. COMMENTS \_\_\_\_\_  
\_\_\_\_\_

# TIDEFLEX<sup>®</sup> ~~TF-1~~ AND TF-2 ALL-RUBBER CHECK VALVES

---

## INSTALLATION, OPERATION, AND MAINTENANCE MANUAL

---



~~TF-1~~

The revolutionary design of the all-rubber Tideflex<sup>®</sup> Check Valve provides reliable backflow protection. This unique duck bill design eliminates costly back-flow from oceans, rivers or storm water and is the ideal valve for effluent diffuser systems.

Tideflex<sup>®</sup> Valves seal on entrapped solids and debris without jamming. Unlike traditional flap gates there are no hinged gates to hang open and no warping or freezing. It's virtually maintenance-free.

The Tideflex<sup>®</sup> Check Valve is available in a wide variety of elastomers and is designed to meet your exact flow specifications.



TF-2

### **IMPORTANT**

Please take a moment to review this manual. Before performing any maintenance on the valve be sure the pipeline has been de-pressurized. The improper installation or use of this product may result in personal injury, product failure, or reduced product life. Tideflex<sup>®</sup> Technologies can accept NO liability resulting from the improper use or installation of this product. If you have any questions or problems, please call the customer service department at (412) 279-0044. We appreciate your comments. Thank you for choosing Tideflex<sup>®</sup> Technologies.

## GENERAL DESCRIPTION

The Tideflex® Technologies' Check Valve is an all-elastomer, one-piece check valve. Terms used in this IOM to refer to various parts of the valve are described below.

1. Cuff - the cuff is designed with a full round bore and slips over the end of the pipe.
2. Saddle - The saddle is the middle part of the valve, tapering from the round cuff to the flat bill. The saddle directs the flow to the bill, and is flexible to sustain increased flow conditions.
3. Bill - the bill is the discharge end of the valve. The bill flexes to allow flow to discharge, yet is stiff enough to prevent the valve from opening without line pressure.

Backpressure, the pressure created on the exterior of the valve by reverse flow or submersion, will seal the lips of the bill tightly together, preventing backflow into the valve.

4. Clamps - The clamps are tightened around the cuff after the cuff has been slipped over the end of the discharge pipe. These clamps are normally furnished by Red Valve Company. Hose clamps are supplied for valves up to 12". Valves 14" and up are supplied with fabricated clamps. 14"-20" are supplied with one set, 20"-54" are supplied with two sets and sizes 60" and up are supplied with three sets.
5. Lifting clevis - lifting clevis is attached to the bill of the check valve for valves 36" and up. This clevis is used during installation to assist in lifting the valve, and may be used to attach a line to the bill to help support the valve after installation.

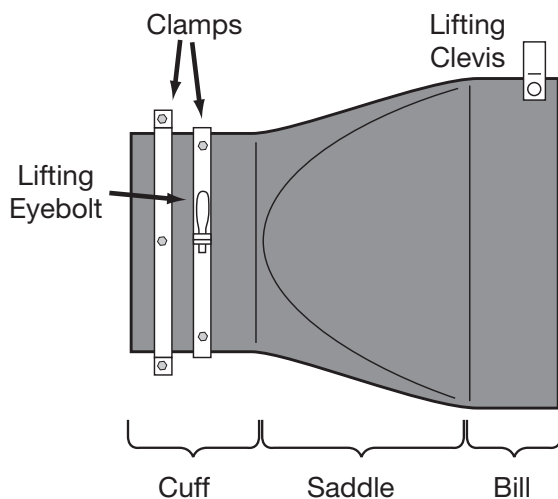

## OPERATION

Tideflex® Check Valves are custom made products intended for a specific application and have been designed to respond to criteria unique to that purpose, such as line pressure, minimum and maximum back pressure and chemical compatibility. Should the conditions for which the valve has been designed be altered or change in any way, it could affect the normal operation of the valve.

Tideflex® Check Valves work on backpressure exerted on the bill area to seal the valve. The bill may appear to be slightly open when installed. This slight opening does not affect the operation of the valve, as the valve depends on backpressure to seal.

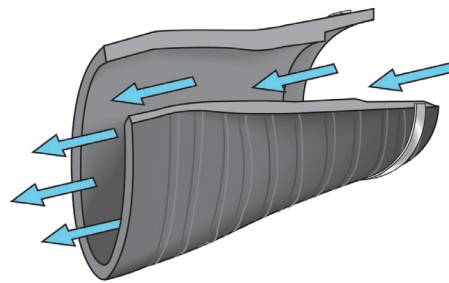

Forward Pressure Opens Valve

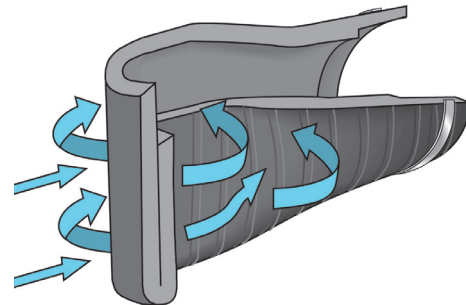

Reverse Pressure Seals Valve

### NEVER...

Cut or modify check valve.

### DO...

Use a soapy water solution to slide check valve on pipe.

### DO...

Keep valve on pallet until ready to install.

### DO...

Tighten clamp bolts evenly.

# STORAGE

Tideflex® Check Valves should be stored in a cool, dry location on original shipping pallet with the bill facing upward, not on its side (see Figure 2). Do not drop, bend or twist check valve, or damage may occur.

1. Store valve in a cool, clean, dry location.
2. Avoid exposure to light, electric motors, dirt or chemicals. Resilient check valves are subject to deterioration when exposed to ozones and non-compatible chemicals. Ozone especially causes age hardening of the elastomer.
3. Store Installation Operation Manual with product so it will be readily available for installation.
4. Do not remove wooden brace or metal shipping ring (36"+) until valve is installed.

Figure 2

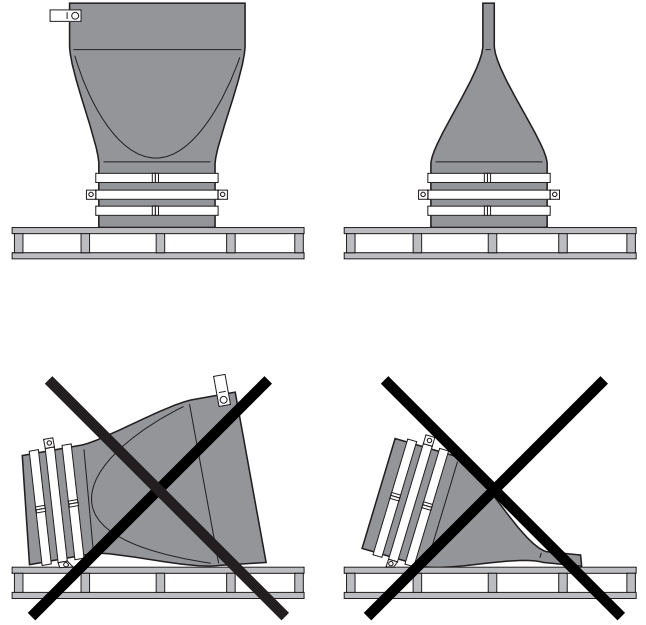

**NEVER STORE HORIZONTALLY**

## INSTALLATION INSTRUCTIONS TIDEFLEX® CHECK VALVES

### 1. INSPECTION OF CHECK VALVE

Check the inside diameter of the cuff of the Tideflex® Check Valve to compare it to the O.D. of the outfall pipe. Inspect the outfall pipe for sharp or damaged areas. The pipeline should be in a smooth condition to prevent cutting the rubber check valve. Lifting clevis and lifting eye bolts are provided only for sizes 36" and over.

Imperfections on the inside of the cuff area can be filled with a silicone sealant prior to installing the valve on the pipe. This will ensure a seal in the cuff area after clamps are tightened.

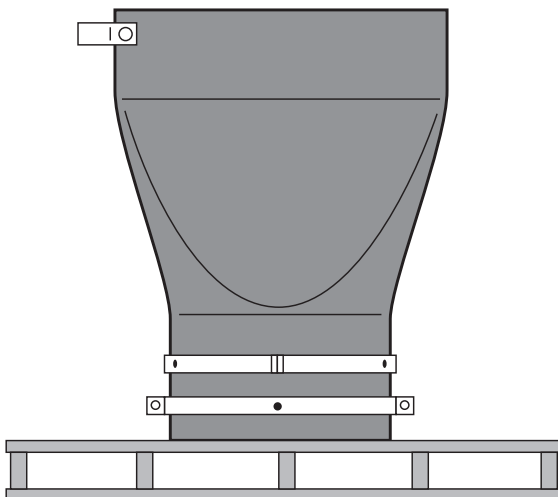

### 2. INSPECTION OF THE PIPE

Check the outside diameter of the pipe to determine if it matches the I.D. of the cuff of the Tideflex® Check Valve. The cuff of the check valve is usually made slightly larger to permit ease of installation.



### 3. CLEARANCE

Make certain that sufficient ground clearance exists below the valve, at least 10% of the valve diameter (i.e. 6" for a 60" valve).

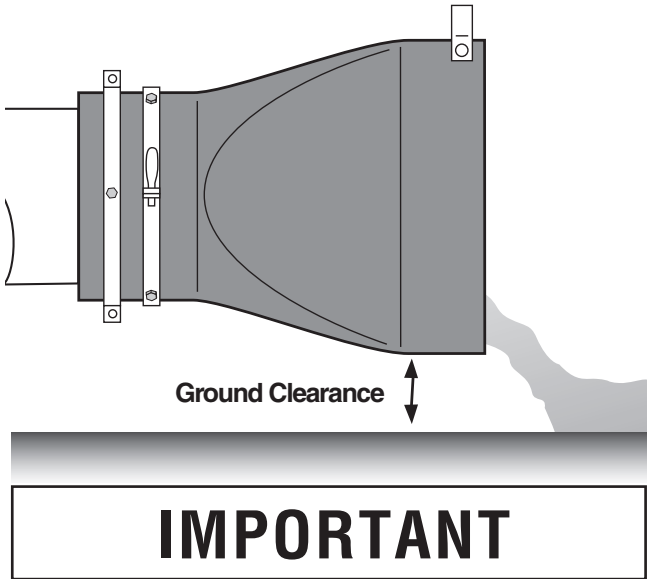

### 4A. TIDEFLEX® WITH CURVED BILL INSTALLATION IN CURRENT

For Tideflex® fabricated with a curved bill, the valve should be installed so the bill points in the direction of the current, not facing the current which may cause the bill to be forced open.

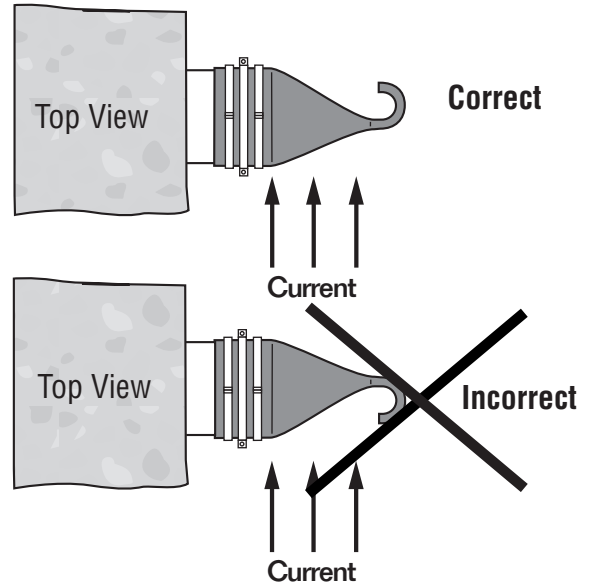

### 5. REMOVING THE VALVE FROM PALLET OR CRATING

A lifting clevis is provided at the top end of the Tideflex® Check Valve. Lifting eye bolts are provided on the clamps. Remove the cuff retainer shipping ring or wooden brace located inside the cuff of the valve. The valve should be lifted from the pallet using both the clevis and the lifting eye bolts.

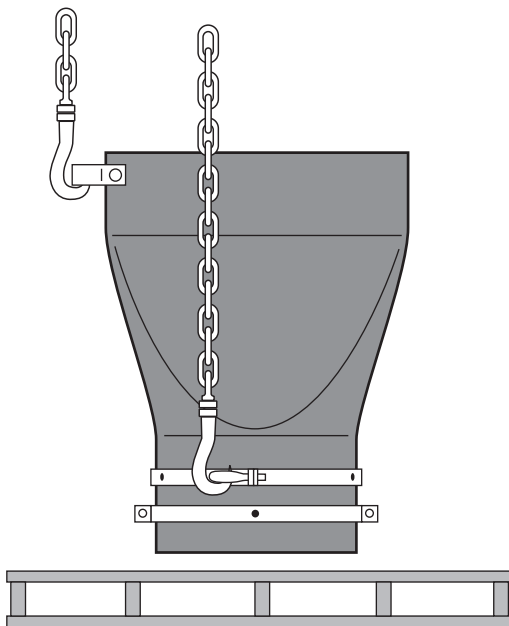

### 4B. FITTING TIDEFLEX® ON PIPE

- A. To facilitate the insertion of the pipe into the Tideflex® Check Valve, it might be necessary to grind a bevel on the inside cuff diameter.
- B. Sometimes it is necessary to grind the inside of the cuff or add gasket material to the O.D. of the pipe to properly fit the Tideflex® Check Valve.

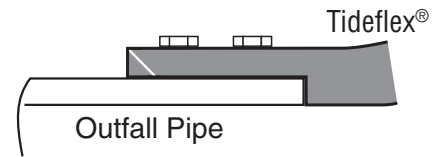

### 6. LIFTING THE VALVE

Do not discard the metal clamps holding the valve onto the pallet. THESE CLAMPS ARE NEEDED to install the Tideflex® Check Valve. In lifting the Tideflex® Check Valve from the pallet, keep the bill end of the Tideflex® higher than the cuff for ease of installation.

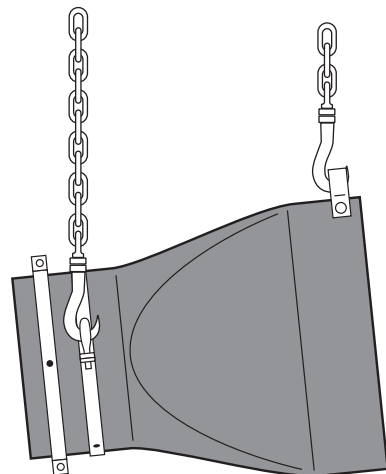

## 7. POSITIONING THE VALVE

Apply a soap/water solution to the outside of the pipe in which the check valve is being installed on, to ease installation.

### TF-2

With the bill end of the Tideflex® lifted higher than the cuff end start to fit cuff on the outfall line. The Tideflex® Check Valve should fit snugly against the outfall pipe, leaving no gap.

### TF-1

Flat portion of the valve to be at the bottom of the pipe. Flare to be at the top.

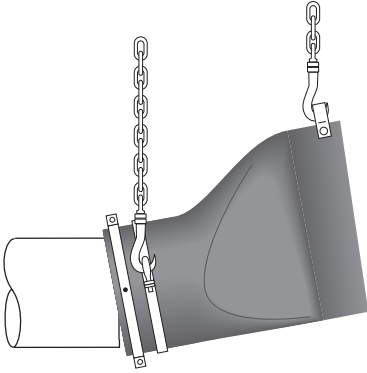

After the unit is securely pegged into position, proceed to install and tighten the first clamp. A mild lubricant may be applied to the I.D. of the clamp to prevent a brake shoe effect when tightening down the clamps.

## 9. POSITIONING FOR TWO CLAMPS

Install the second clamp on the cuff of the Tideflex®. Rotating the clamp 90° in relation to the first clamp will ensure even pressure around the valve and pipe, thus increasing the effectiveness of the clamps.

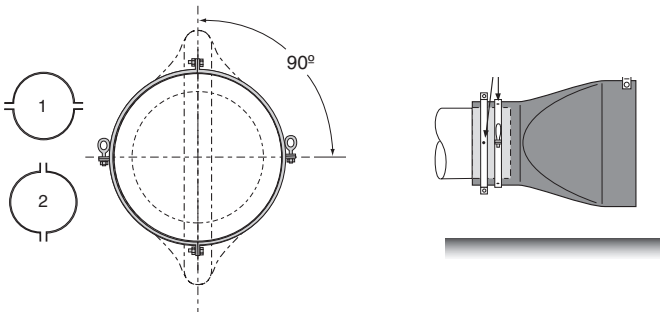

If a greater distance between the angles of the clamps is required to provide more range for tightening the bolts, especially if angles are bottoming out, gasket material can be wrapped around the O.D. of the cuff as shown.

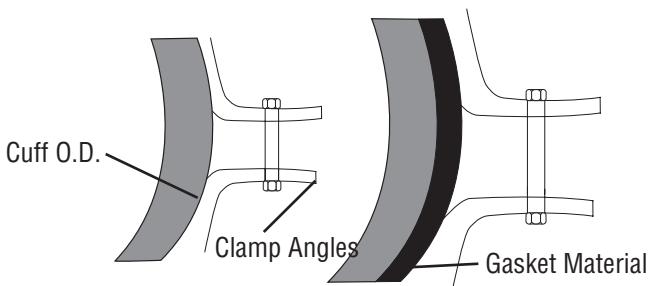

## 8. SEAT TIDEFLEX® ON PIPE

The Tideflex® Check Valve should fit snugly against the outfall pipe, leaving no gap. If possible, inspect installation from the inlet end of the Tideflex® Check Valve to insure that the check valve cuff fits snugly on the pipe. Do not allow a gap between the cuff and the end face of the outfall pipe. A gap will create an imbalance which will not provide proper support for the Tideflex® Check Valve. For more information, see troubleshooting.

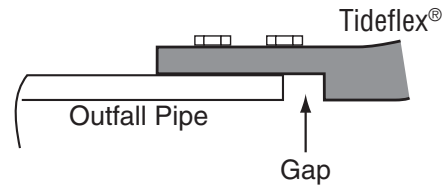
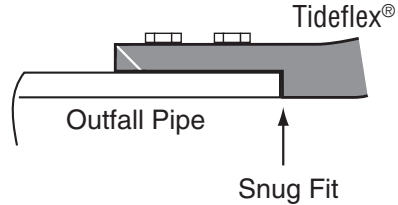

## 10. POSITIONING FOR THREE CLAMPS

After the unit is securely pegged into position, proceed to install and tighten the first clamp. A mild lubricant may be applied to the I.D. of the clamp to prevent a brake shoe effect when tightening down clamps.

Install the second and third clamps on the cuff of the Tideflex®. Rotating the first and second clamps 60° and 120°, respectively, in relation to the first clamp will ensure even pressure around the valve and pipe, thus increasing the effectiveness of the clamps.

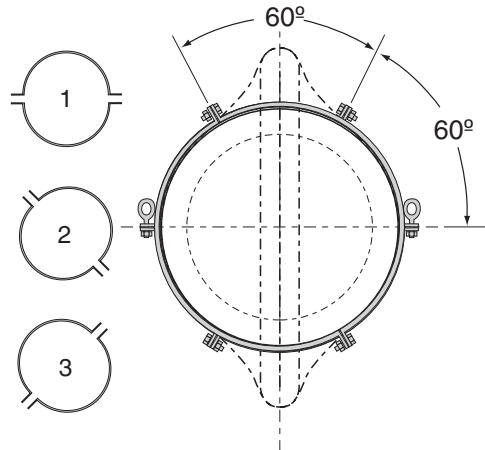

## 11. POSITIONING BLANK HOLES IN CLAMPS

Tighten all clamps and bolts once all components have been positioned properly. Pre-drilled holes are drilled in each clamp. These are provided so as to secure the Tideflex® Check Valve with holding pins to the outfall pipe. This will secure the Tideflex® Check Valve to the pipe and assure a long, trouble-free service life. After tightening the clamps, the pre-drilled holes should be staggered. Holes are not drilled in the rubber cuff of the Tideflex® at the factory since they would not line up to the tightened clamps.

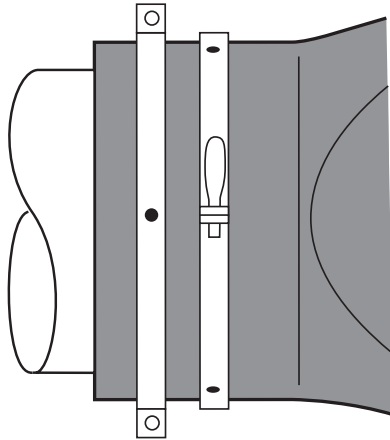

## 12. TACK WELDING HOLDING BOLTS TO CLAMPS

Once clamps are secure use a standard steel drill bit and drill holes through the rubber cuff. Insert holding bolts through the cuff and secure opposite side with nut, if possible. Holding bolts should be stainless steel. Steel bolts can corrode and break off, causing the check valve to slip off the pipe. Holding bolts are not provided because of various widths of the outfall pipe.

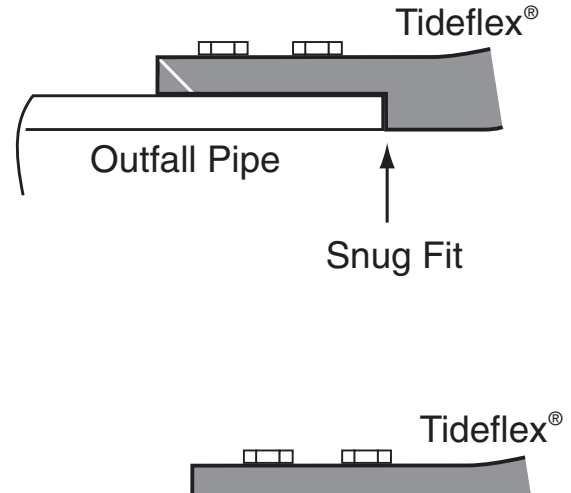

## 13. BOLTS TACK WELDED TO CLAMPS

After tightening, heads of holding bolts can be tack welded to the clamps using small tacks. Certain installations will not permit installing of nuts to bolts. In these situations, the tightness of the clamps and tack weld of the bolts will assure good support.

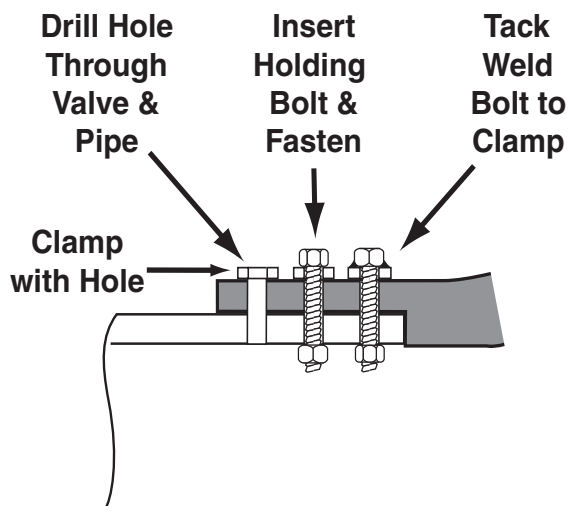

## 14. CORRUGATED PIPE AND SMOOTH WALL (PVC, HDPE) PIPE INSTALLATION

For installation on corrugated pipe, it is recommended that the corrugations be filled with hydraulic cement (or similar material) that will provide a smooth O.D.

For smooth wall pipe, it is recommended that the valve be pinned.

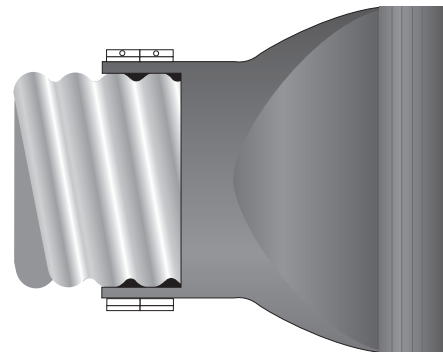

## TROUBLESHOOTING

### Valve will not fit to pipe:

- Make certain that the inside cuff retainer ring has been removed prior to fitting the valve to the pipe.
- Verify that the valve has enough area to fit over the pipe.
- If the pipe can be removed, or if an adapter ring which bolts to the wall or inside a vault is used, a crane or high-lift may be used to lower the valve onto the ring with the valve turned on end and the bill facing up.

### Valve will not close fully, or check flow in opposing direction:

- Possible obstruction in line. Inspect the valve for entrapped foreign objects which may have lodged between the lips of the valve.
- Valve may not be installed high enough to clear the ground under the bill. Ensure that there is enough space between the bottom of the valve and the ground in order to prevent contact of the two or debris build-up.
- Backpressure may not be sufficient to completely seal the valve.
- The valve may not have been installed in a vertical position.

### Valve will not stay on pipe:

- Check all clamp bolts to assure that all bolts are tightened sufficiently.
- Valve may not be fully seated onto outfall line.
- Clamps are not rotated 90° from each other in order to provide adequate holding power.
- Valve cuff has a much larger I.D. in relation to pipe O.D.
- Make sure holding pins are used on 42" and larger check valves in order to prevent the valve from slipping off the line.

TF-2 Check Valves are designed to slide over a pipe stub. Too short of a pipe stub may cause the check valve to slip off or cause the check valve to gap open.

For valves up to 4", the pipe stub length "B" should be a minimum of 1/2" longer than cuff depth "A".

6"-14"	1" longer
16"-24"	2" longer
30"-60"	2 1/2" longer
72" and up	3" longer

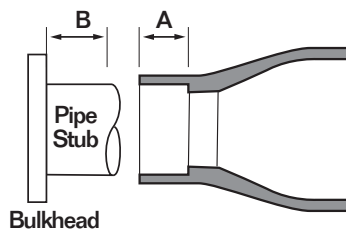

### Hints to install large diameter check valves:

During the installation of the check valve, if force is needed to seat the valve to the cuff stop on large diameter check valves, the force required should be induced equally around the cuff of the check valve, never at only the top, bottom or in the center. The force required to push the check valve onto the pipe can be placed on the bill but it should be distributed evenly over the entire length of the bill. Failure to distribute the pressure equally may cause improper performance of the check valve. Use a wide angle iron or large wooden planks across the bill to distribute the force equally.

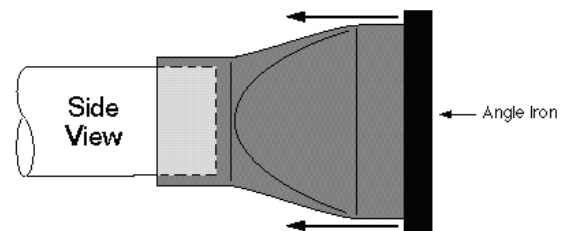
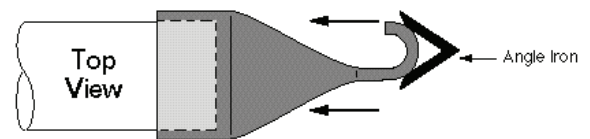
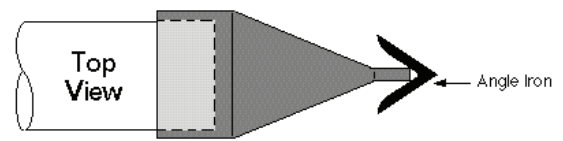

---

## MAINTENANCE

Line pressure should flush the valve clean of debris in most cases. Periodic inspections for trapped debris should be conducted.

In vacation seashore areas quart size plastic bottles have a tendency to float on top and not flush through except during a major storm.

A feathered 1" x 4", 1-1/2" x 12", or suitable plank inserted into the bill of the valve and turned 90° is a simple method of clearing the check valve of small debris which may be trapped between the lips.

**CAUTION:** Sharp objects should not be used on the Tideflex® Check Valve, as there is a chance of cutting the rubber and damaging the protective fabric covering.

Any gouges in the cover wrap that occur should be sealed to safeguard against ozone or chemical attack. This is best done with rubber cement or a good brand of silicone or polyurethane rubber sealer made by the major manufacturers.

## Tideflex® Technologies Warranty

WARRANTIES - REMEDIES - DISCLAIMERS - LIMITATION OF LIABILITY

Unless otherwise agreed to in writing signed by Tideflex® Technologies, all Products supplied by Tideflex® Technologies will be described in the specifications set forth on the face hereof.

THE WARRANTIES SET FORTH IN THIS PROVISION ARE EXCLUSIVE AND IN LIEU OF ALL OTHER WARRANTIES WHETHER STATUTORY, EXPRESS OR IMPLIED (INCLUDING ALL WARRANTIES OF MERCHANTABILITY AND FITNESS FOR A PARTICULAR PURPOSE AND ALL WARRANTIES ARISING FROM COURSE OF DEALING OR USAGE OR TRADE).

Tideflex® Technologies Products are guaranteed for a period of one year from date of shipment, against defective workmanship and material only, when properly installed, operated and serviced in accordance with Tideflex® Technologies' recommendations. Replacement for items of Red Valve's manufacture will be made free of charge if proved to be defective within such year; but not claim for transportation, labor or consequential damages shall be allowed. We shall have the option of requiring the return of the defective product to our factory, with transportation charges prepaid, to establish the claim and our liability shall be limited to the repair or replacement of the defective product, F.O.B. our factory. Tideflex® Technologies will not assume costs incurred to remove or install defective products nor shall we incur backcharges or liquidated damages as a result of warranty work. Tideflex® Technologies does not guarantee resistance to corrosion erosion, abrasion or other sources of failure, nor does Tideflex® Technologies guarantee a minimum length of service, or that the product shall be fit for any particular service. Failure of purchaser to give prompt written notice of any alleged defect under this guarantee forthwith upon its discovery, or use, and possession thereof after an attempt has been made and completed to remedy defects therein, or failure to return product or part for replacement as herein provided, or failure to install and operate said products and parts according to instructions furnished by Tideflex® Technologies, or failure to pay entire contract price when due, shall be a waiver by purchaser of all rights under these representations. All orders accepted shall be deemed accepted subject to this warranty which shall be exclusive of any other or previous warranty, and shall be the only effective guarantee or warranty binding on Tideflex® Technologies, anything on the contrary contained in purchaser's order, or represented by any agent or employee of Tideflex® Technologies in writing or otherwise, notwithstanding implied warranties. Tideflex® Technologies MAKES NO WARRANTY THAT THE PRODUCTS, AUXILIARIES AND PARTS ARE MERCHANTABILITY OR FIT FOR ANY PARTICULAR PURPOSE.



600 North Bell Avenue  
Carnegie, PA 15106  
Phone: 412 279-0044  
Fax: 412 279-7878  
Web: [www.tideflex.com](http://www.tideflex.com)

TF-1/TF-2 IOM Rev. 10/16/15