



Western Water Constructors, Inc.
Submittal Cover

Job no. 16-05



CONTRACT NAME: Manteca WQCF Digester Improvements
SPEC SECTION: 15115 Gate, Globe, and Angle Valves
SUBMITTAL TITLE: Gate Valves - O&M
FILE NAME: 217-R0_15115-03_Gate Valves-OM

SUB #: 217
REV #: 0
CODE: 15115-03
DATE: 11/16/2017

WWC REVIEW/COMMENTS: [X] NO EXCEPTIONS [] EXCEPTIONS / DEVIATIONS AS NOTED

REVIEWED BY: ST

SIGNED: [Signature]

WWC HAS REVIEWED THIS SUBMITTAL FOR CONFORMANCE WITH THE PROJECT PLANS & SPECIFICATIONS.

OWNER REVIEW:

Table with columns: ITEM, DESCRIPTION, REVIEW STATUS (A, B, C, D, E). Row 1: 1, Gate Valves O&M, [] [] [] [] []

LEGEND: A = No Exceptions Taken B = Make Correction Noted C = Correct & Resubmit
D = Rejected E = Accepted for Record

OWNER COMMENTS:

REVIEWER'S NAME: _____

REVIEWER'S SIGNATURE: _____

DATE: _____

EQUIPMENT SUMMARY FORM

1. EQUIPMENT ITEM Gate valve
2. MANUFACTURER Clow Valve Co
3. EQUIPMENT IDENTIFICATION NUMBER(S) _____
(maps equipment number)
4. LOCATION OF EQUIPMENT _____
5. WEIGHT OF INDIVIDUAL COMPONENTS (OVER 100 POUNDS) _____

6. NAMEPLATE DATA - Horsepower _____
Amperage _____
Voltage _____
Service Factor (S.F.) _____
Speed _____
ENC Type _____
Capacity _____
Other _____
7. MANUFACTURER'S LOCAL REPRESENTATIVE
Name Clow Valve Co
Address 902 S 2nd St, Oskaloosa, IA 5257
Telephone Number (641) 673-8611
8. MAINTENANCE REQUIREMENTS _____

9. LUBRICANT LIST _____

10. SPARE PARTS (recommendations) _____

11. COMMENTS _____

CLOW VALVE COMPANY
902 S. 2nd St.
Oskaloosa, Iowa 52577
641-673-8611

RESILIENT WEDGE GATE VALVE

2"-12" NRS

O & M MANUAL

TABLE OF CONTENTS

Page 1	General Info/Installation Instructions
2-3	Operation/Inspection & Maintenance
4	Records
5	RW GV 2"-12" Parts List
6	RW GV Disassembly
7	Trouble Shooting
8	Warranty

CLOW VALVE COMPANY

902 S. 2nd St.

Oskaloosa, Iowa 52577

641-673-8611

INSTALLATION, OPERATION AND MAINTENANCE MANUAL

RESILIENT SEAT GATE VALVE

GENERAL: Inspect all valves at time of delivery for shipping damage and to confirm compliance with specifications. Valves are completely tested per the appropriate standards and specifications by the manufacturer. The valves should be stored in such a manner to protect them from weather and blowing dirt and debris. In cold climates, if water is allowed to freeze in the valve, severe damage to the valve components could result. Any packaging should be replaced if removed for inspection. Proper slinging and handling methods should be used when moving valves. Do not place slings or other devices around operating stem or through the valve port opening.

I. Installation

1. Check that valve end joints are clean. Again check for damage to the valve. Open and close valve to insure proper operation. Close wedge before placing valve in trench or line.
2. Handle valve carefully. Do not drop into position. Do not sling through the port opening.
3. Prepare pipe ends according to manufacturer's instructions. Install valve per proper methods according to end joint type. All piping should be properly supported to avoid line stress on the valve. Do not use the valve as a jack to force a pipeline into position.
4. A valve box or vault should be provided for each valve used in buried service application. These should be installed such that no load is transferred to the valve.
5. Before pressurization of the pipeline and valve, all pressure containing bolting (cover, follower plate, end connection) should be inspected for adequate tightness (usually 90 ft. lbs.).
6. Buried valves should be pressurized before backfilling.

7. With valve in open position, the entire system should be thoroughly flushed to clean the system. Debris in the valve could prevent valve from closing or possibly damage the resilient material on the wedge.
8. Upon completion of the installation, gate valve location, size, type, date of installation, number of turns to open, direction of opening, and any other special information should be entered on permanent records.

II. Operation

1. Do not operate valves in systems that exceed the rated working pressure of the valve, (2"-20" 250 psi, 24" 200 psi).
2. System should be completely flushed before valve is operated in normal cycle.
3. The R/W valve opens and closes by turning the main valve stem with an operating nut or handwheel. The valve closes by compressing the resilient material bonded to the wedge against the valve body.
4. If the valve should fail to seal after necessary number of turns, open the valve four or five times and reseal.

Emergency Operation:

Turn the handwheel of operating nut faster in the desired direction.

III. Inspection and Maintenance

1. Frequency of inspection should be based on frequency of operation. Semi annual inspections are minimum recommended. Valves should not be disassembled unless a breakdown has occurred.
2. During inspection, the valve should be opened and closed with pressure in the pipeline. The valve should function freely with no binding or vibration. Count the number of turns to full closed. This will reveal an obstruction if correct number of turns are not achieved. See table:

TURNS TO OPEN			
2" - 4 ¾	14" - 52	with spur gear - 104	with bevel gear - 104
2 ½" - 5 ½	16" - 52	with spur gear - 104	with bevel gear - 104
3" - 10	18" - 64	with spur gear - 192	with bevel gear - 192
4" - 13 ½	20" - 64	with spur gear - 192	with bevel gear - 192
6" - 19 ½	24" - 76	with spur gear - 228	with bevel gear - 228
8" - 25 ½			
10" - 31 ½			
12" - 37 ¾			

RW GV O & M CONTINUED

3. All gaskets and joints should be checked for leakage and tightness.
4. With the valve closed and pressure against the wedge, a check for leakage is possible by “listening” to the valve for flow. A stethoscope will help in this procedure.
5. Attached actuators should be inspected per manufacturer’s recommendations provided with those units.
6. OS&Y valves should have the exposed stem lubricated at each inspection. Check stuffing box bolts for tightness.
7. A permanent inspection record should be kept for each valve.

RECORDS

1. Trouble can be anticipated with a good Inspection Program. Such a program cannot exist without good records. Poor records are worse than none.

2. A printed 5 x 8 record card for each valve and hydrant in the system is most convenient.
 - a. Identification of each valve and hydrant is essential. Setting up a numbering system is one of the first steps to take. A reasonably simple method is to assign a number to each street intersection, then identify each valve or hydrant numerically or alphabetically between intersection numbers.

For instance: I9-I10, would be the number of second valve from street intersection number 9 going toward street intersection number 10.

Another convenient device is to assign only odd numbers to existing hydrants. When hydrants are added later, they can be given numbers which will fit in the numerical sequence.

- b. Location should be recorded first. Measurements must be made from property lines or street center lines – not power poles, fence lines, or the like.

Valve Record

No. _____

Location _____ FT. _____ of _____ Prop. Line of _____
and _____ FT. _____ of _____ Prop. Line of _____

Size _____ Make _____ Type _____ Gearing _____ Bypass _____

Opens _____ Turns to Operate _____ Depth to Nut _____

Remarks _____

Maintenance and Inspection Record

Date	Work Done	O.K.	By	Date	Work Done	O.K.	By

**2"-12" RW VALVE
MATERIAL LIST
CLOW VALVE COMPANY**

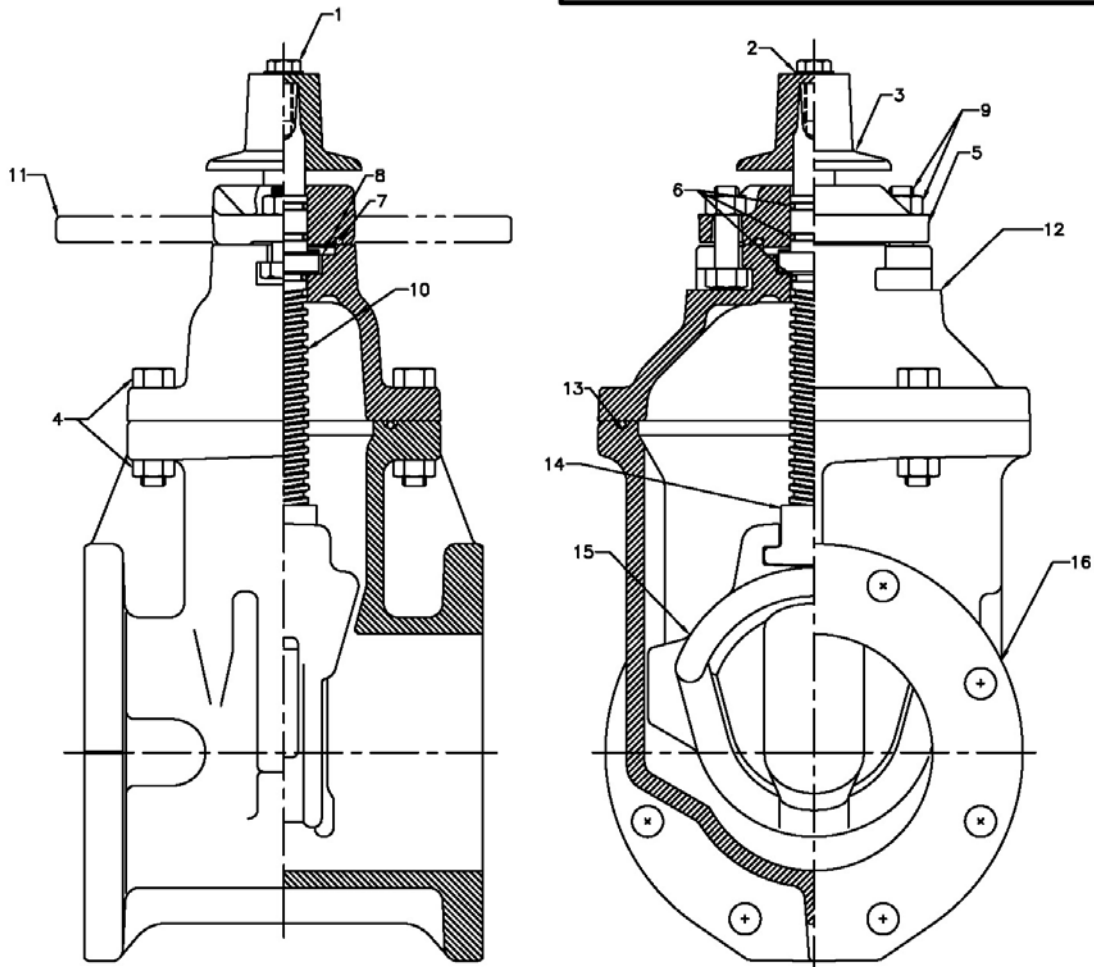

ITEM	DESCRIPTION
1	Hex Head Bolt
2	Flat Washer
3	Operating Nut
4	Hex Head Bolts & Nuts
5	Follower Plate
6	Stem O-Ring
7	Follower Plate O-Ring/gasket
8	Thrust Washer Bearing
9	Hex Head Bolts & Nuts
10	Stem
11	Indicator Post Plate (Optional 3-12")
12	Cover
13	Cover O-Ring
14	Stem Nut
15	Wedge
16	Body - all types

DISSASSEMBLY INSTRUCTIONS
FOR
CLOW NRS RESILIENT SEAT GATE VALVE

1. Remove capscrew (Item #1) and washer (#2)
2. Remove handwheel or operating nut (#3)
3. Remove o-ring plate nuts (#9)
4. Remove o-ring follower plate (#5)
5. Remove stem (#10) by turning stem in opposite direction for opening valve.
6. Remove cover bolts & nuts (#4)
7. Lift off cover (#12)
8. Grasp stem nut (#14) and lift out wedge (#15)
9. Reassemble in reverse order replacing cover o-ring (#13), stem o-rings (#6), follower plate o-ring (#7) and thrust washer (#8) if necessary.

**Troubleshooting
RW GV's**

<u>Possible Malfunction</u>	<u>Symptoms – Causes</u>	<u>Corrective Action</u>
<i>Joint Leakage</i>	<i>Bolt Tension Relaxing</i>	<i>Tighten Bolts</i>
<i>Seat Leakage</i>	<i>Foreign Material Caught in Seat</i>	<i>Operate Valve to flush out debris</i>
	<i>Seats Dirty/Corroded</i>	<i>Flush or Disassemble & clean</i>
	<i>Seats Damaged</i>	<i>Inspect-Repair or Replace</i>
<i>Leak Past Stem</i>	<i>Bolts Loose</i>	<i>Tighten Bolts</i>
	<i>(NRS) O-rings worn, damaged</i>	<i>Inspect/Replace</i>
	<i>(OS&Y) Packing worn, damaged</i>	<i>Inspect/Replace</i>

*Inspection for the above should be done semi-annually at the minimum.
There are no lubrication requirements other than:
OS&Y valves should have the exposed stem* lubricated at each
Inspection.*

**Mobil Lube*

For Parts and Service, Contact Manufacturer's Rep:

CLOW VALVE COMPANY
902 S. 2nd St.
Oskaloosa, Iowa 52577
641-673-8611

CLOW RESILIENT SEAT VALVES

TEN YEAR LIMITED WARRANTY

Clow Valve Company warrants that its RW valves will be free from defects in material and workmanship under normal and customary use and maintenance for a period of ten (10) years from the date of purchase, provided the valve is installed and maintained according to Clow instruction, and applicable codes. The foregoing warranty does not cover failure of any part or parts from external forces, including but not limited to earthquake, vandalism, vehicular or other impact, and application of excessive torque to the operating mechanism or frost heave.

Should any Clow Valve Company part or parts fail to conform to the foregoing warranty, Clow shall, upon prompt written notice thereof, repair or replace, F.O.B. point of manufacture, such defective part or parts. Purchaser shall, if requested, return the part or parts to Clow, transportation prepaid. Purchaser shall bear all responsibility and expense incurred for removal, reinstallation and shipping in connection with any part supplied under the foregoing warranty.

THE FOREGOING WARRANTY IS IN LIEU OF AND EXCLUDES ALL OTHER WARRANTIES NOT EXPRESSLY SET FORTH HEREIN, WHETHER EXPRESS OR IMPLIED BY OPERATION OF LAW OR OTHERWISE, INCLUDING BUT NOT LIMITED TO ANY WARRANTIES OF MERCHANTABILITY OR FITNESS. IN NO EVENT SHALL CLOW VALVE COMPANY BE RESPONSIBLE OR LIABLE FOR ANY INCIDENTAL OR CONSEQUENTIAL LOSSES, DAMAGES OR EXPENSES.

