



Western Water Constructors, Inc.
Submittal Cover

Job no. 16-05



CONTRACT NAME: Manteca WQCF Digester Improvements
SPEC SECTION: 15119 Air and Vacuum Relief Valves
SUBMITTAL TITLE: Wastewater Air Release Valve - O&M
FILE NAME: 213-R0_15119-03_Wastewater Air Release Valve-OM

SUB #: 213
REV #: 0
CODE: 15119-03
DATE: 11/16/2017

WWC REVIEW/COMMENTS: [X] NO EXCEPTIONS [] EXCEPTIONS / DEVIATIONS AS NOTED

REVIEWED BY: ST

SIGNED: [Signature]

WWC HAS REVIEWED THIS SUBMITTAL FOR CONFORMANCE WITH THE PROJECT PLANS & SPECIFICATIONS.

OWNER REVIEW:

Table with columns: ITEM, DESCRIPTION, REVIEW STATUS (A, B, C, D, E). Row 1: 1, Wastewater Air Release Valve O&M, [] [] [] [] []

LEGEND: A = No Exceptions Taken B = Make Correction Noted C = Correct & Resubmit
D = Rejected E = Accepted for Record

OWNER COMMENTS:

REVIEWER'S NAME: _____

REVIEWER'S SIGNATURE: _____

DATE: _____

EQUIPMENT SUMMARY FORM

1. EQUIPMENT ITEM Air release valve
2. MANUFACTURER Valmatic
3. EQUIPMENT IDENTIFICATION NUMBER(S) _____
(maps equipment number)
4. LOCATION OF EQUIPMENT _____
5. WEIGHT OF INDIVIDUAL COMPONENTS (OVER 100 POUNDS) _____

6. NAMEPLATE DATA - Horsepower _____
Amperage _____
Voltage _____
Service Factor (S.F.) _____
Speed _____
ENC Type _____
Capacity _____
Other _____
7. MANUFACTURER'S LOCAL REPRESENTATIVE
Name Crump & Company
Address P.O. Box 94836 Pasadena, CA 91109-4836
Telephone Number 626-794-1685
8. MAINTENANCE REQUIREMENTS _____

9. LUBRICANT LIST _____

10. SPARE PARTS (recommendations) _____

11. COMMENTS _____

Wastewater Air Release Valve Models 48A, 49A

Operation, Maintenance and Installation Manual

INTRODUCTION	1
RECEIVING AND STORAGE.....	1
DESCRIPTION OF OPERATION	1
INSTALLATION.....	2
VALVE CONSTRUCTION	2
MAINTENANCE	3
TROUBLESHOOTING	4
DISASSEMBLY	4
REASSEMBLY	4
PARTS & SERVICE	5
WARRANTY	6



VALVE AND MANUFACTURING CORP.

905 Riverside Dr. • Elmhurst, IL 60126
Phone (630) 941-7600 • Fax (630) 941-8042
www.valmatic.com

VAL-MATIC'S WASTEWATER AIR RELEASE VALVE OPERATION, MAINTENANCE AND INSTALLATION

INTRODUCTION

This manual will provide you with the information to properly install and maintain the valve to ensure a long service life. The Wastewater Air Release Valve has been designed with stainless steel trim to give years of trouble-free operation but regular maintenance is recommended for valves subject to fluids containing suspended solids or greases/oils. The Wastewater Air Release Valve is typically mounted at the high points in a piping system to automatically remove pockets of air as they accumulate. The valve can also be used to slowly release air in tanks and pump casings.

CAUTION: This valve is not intended for fuel liquids service.

The valve is a float-operated, resilient-seated valve designed to handle waste fluids. The valve may be equipped with backwash accessories. The Size, Maximum Working Pressure and Model No. are stamped on the nameplate for reference.

RECEIVING AND STORAGE

Inspect valves upon receipt for damage in shipment. Handle all valves carefully without dropping. Valves should remain boxed, clean and dry until installed to prevent weather related damage. For long term storage greater than six months, the valve must remain in the box and stored indoors. Do not expose valve to sunlight or ozone for any extended period.

DESCRIPTION OF OPERATION

The Wastewater Air Release Valve is designed to automatically remove air pockets at the high points in a piping system. The valve, as shipped, is a normally open valve and will slowly vent air through the top orifice. As fluid enters the valve, the float will rise, closing the orifice. As air accumulates in the piping system and enters the valve, the float drops allowing the venting orifice to open.

The valve can be equipped with optional external valves and hose connections for backwashing. These items are packaged separately.

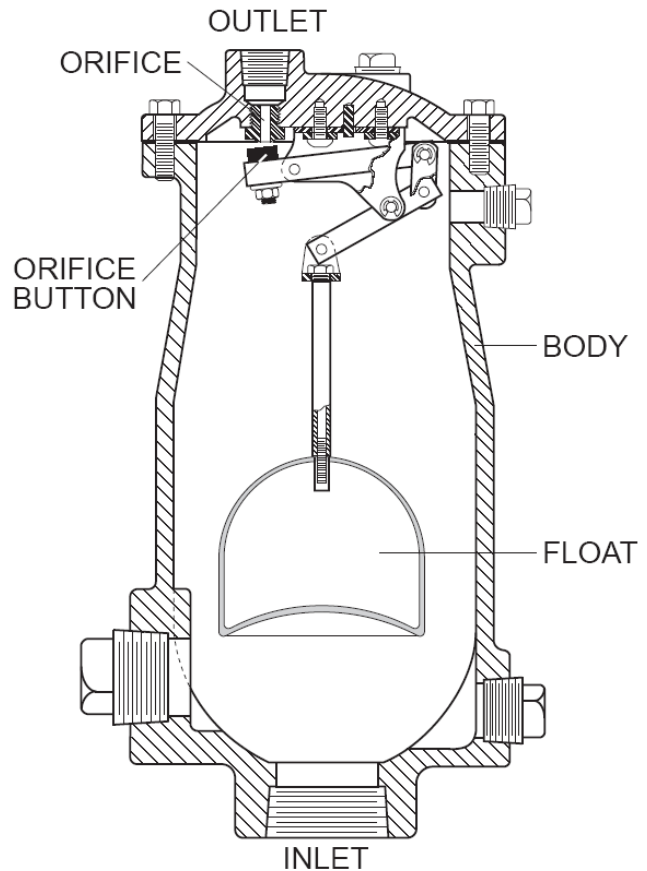

FIGURE 1. WASTEWATER AIR RELEASE VALVE

The lever mechanism provides mechanical advantage for the float. During system operation, the pipeline pressure exerts a strong upward force on the sealing component, the orifice button. The lever mechanism magnifies the weight of the float so that the orifice will open under high pipeline pressures. Additional ports are provided for flushing, testing and draining purposes.

INSTALLATION

The installation of the valve is important for its proper operation. Valves must be installed at the system high points in the vertical position with the inlet down. For pipeline service, a vault with freeze protection, adequate screened venting, and drainage should be provided. During closure, some fluid discharge will occur so vent lines should extend to an open drain area in plant service. A shut-off valve should be installed below the valve in the event servicing is required.

CAUTION: Install valve with "INLET" port down or leakage will occur.

VALVE CONSTRUCTION

The standard Wastewater Air Release Valve body and cover are cast iron. See the specific Materials List submitted for the order if other than standard cast iron construction. All internal components are stainless steel with the exception of the orifice button which is resilient. The general details of construction are illustrated in Figure 2. The body (1) is threaded for connection to the pipeline. The seat (4) is threaded into the cast cover (2).

ITEM	DESCRIPTION	MATERIAL
1	Body	Cast Iron
2	Cover	Cast Iron
3	Leverage Frame*	Stainless Steel
4	Seat*	Stainless Steel
5	Float*	Stainless Steel
6	Gasket*	Non-Asbestos
7	Cover Bolt	Alloy Steel
8	Retaining Screw*	Stainless Steel
10	Float Arm*	Stainless Steel
11	Orifice Button*	Buna-N
12	Pivot Pin*	Stainless Steel
13	Retaining Ring*	Stainless Steel
14	Pipe Plug	Iron
17	Float Retainer*	Stainless Steel
18	Lock Nut*	Stainless Steel
19	Link*	Stainless Steel
20	Extension Shaft*	Stainless Steel
21	Locating Pin	Stainless Steel
22	Orifice Button Arm*	Stainless Steel
28	Pipe Plug	Malleable Iron
30	Washer*	Stainless Steel
33	Clevis*	Stainless Steel
34	Lock Washer*	Stainless Steel
35	Retaining Screw*	Stainless Steel
36	Pipe Plug	Malleable Iron

*RECOMMENDED REPAIR PART KIT

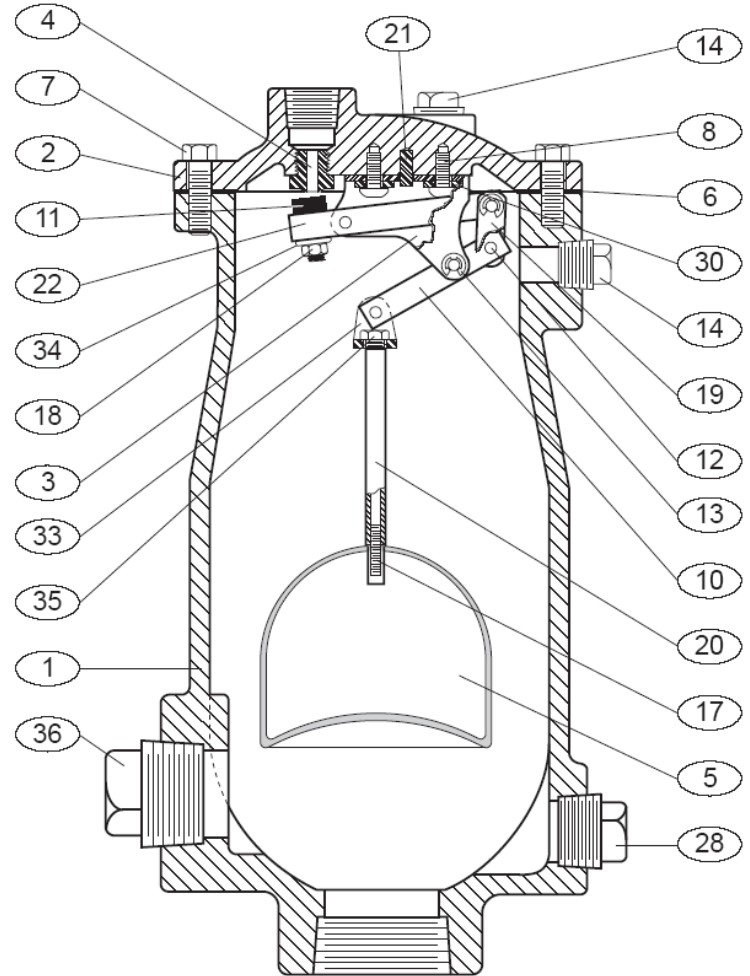

FIGURE 2. WASTEWATER AIR RELEASE VALVE

TABLE 1. LIST OF PARTS

Option Backwash Assembly

Refer to the drawing on page 3 for the correct piping arrangement. Please note the each Kit contains extra fittings such as reducer bushings that may not be needed for your valve. The fittings should be installed with a standard pipe compound such as Oatey White Thread Sealant (supplied) or sealing tape. The quick disconnect fittings are designed for easy push and turn connections to a clean water source.

1. Pipe valve B to a drain prior to backwashing.
2. Close inlet valve A.
3. Open valve B.
4. Connect water supply to E and supply water for 3 minutes to flush seat and mechanism area.
5. Re-connect water supply to C and open valve D to wash the valve body for 1 minute.
6. Close valves D and B.
7. Slowly open valve A to place unit back in service.

Backwash Accessory Kits			
Type	Inlet	Backwash Kit	Valve Models
Air Release Valve	2"	SPK-48ABW	48ABW, 48A.4BW
			49ABW, 49A.4BW
	3"	SPK-48A.2BW	48A.2BW, 48A.5BW
			49A.2BW, 49A.5BW
	4"	SPK-48A.3BW	49A.3BW, 48A.6BW
			49A.3BW, 49A.6BW

MAINTENANCE

The Wastewater Air Release Valve should be scheduled for regular inspection on an annual basis. Based on experience in service, a more frequent backwash regimen may be desirable to minimize leakage.

WARNING: Wear safety glasses to look into the valve outlet after installation. Released fluid can cause injury.

Inspection: Periodic inspection to verify operation can be performed. The valve should not leak fluid at any connection or through the outlet. If there is leakage through the outlet, perform a backwash procedure on the valve. Check to see that air is being released by cracking open the lower drain valve. If a large amount of air is released from the drain valve, then the main valve may be clogged and cleaning or a backwash procedure should be performed.

Lubrication: The Wastewater Air Release valve is a self-contained automatic valve and does not require and lubrication to enhance its operation.

Tools: No special tools are needed to maintain or repair the valve. The valve can be equipped with backwash valves and hoses for ease of backwashing.

Backwash Procedure: In order to properly backwash the valve, a ½" clean water supply of at least 30 psi is needed. This supply should be connected to the rubber hose with quick disconnect couplings as provided with the wastewater valve and shown in Figure 3.

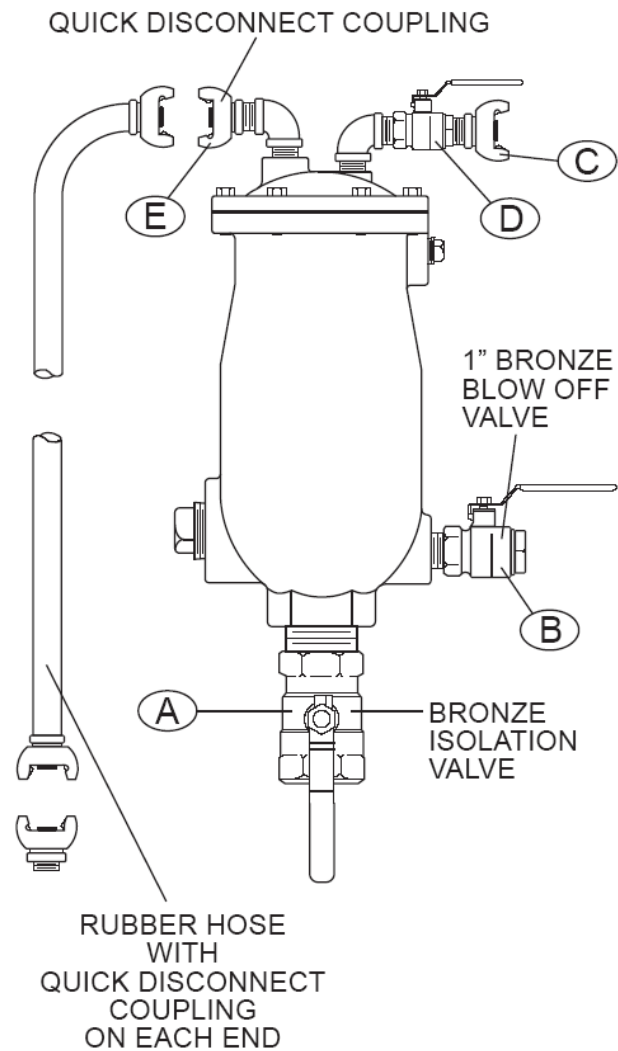

FIGURE 3. BACKWASH HARDWARE

TROUBLESHOOTING

Several problems and solutions are presented below to assist you in troubleshooting the valve assembly in an efficient manner.

- Leakage at Bottom Connection: Tighten valve threaded connection. If leak persists, remove valve and seal threads with Teflon* sealant.
- Leakage at Cover: Tighten bolts per Table 2, replace gasket.
- Valve Leaks when Closed: Backwash valve to remove debris. Disassemble and inspect seat, orifice button, and float. NOTE: Many floats contain sand for weight but if water is detected, replace float.
- Valve not Venting Air: Check that operating pressure does not exceed Working Pressure on nameplate. Backwash valve.

DISASSEMBLY

The valve can be disassembled without removing it from the pipeline. Or for convenience, the valve can be removed from the line. All work on the valve should be performed by a skilled mechanic with proper tools. No special tools are required.

WARNING: The valve must be drained before removing the cover or pressure may be released causing injury.

1. Close inlet shut-off valve. Open drain valve or remove drain plug. Remove the cover bolts (7) on the top cover.
2. Pry cover (2) loose and lift off valve body.
3. Remove the 2 retainer rings (13) and pivot pins (12) that pass through the lever frame (3). The float (5) and linkage will be free from the cover. Disconnect float from lever (10).

DISASSEMBLY (Cont'd)

4. To remove lever frame (3), remove two round-head fasteners (8). Rotate seat (4) counter-clockwise to remove.
5. Remove locknut (18) and orifice button (11) from orifice button arm (22).
6. Clean and inspect parts. Note: some floats contain sand for extra weight; if water is detected, replace float. Replace worn parts as necessary.

REASSEMBLY

All parts must be cleaned and gasket surfaces should be cleaned with a stiff wire brush in the direction of the serrations or machine marks. Worn parts, gaskets and seals should be replaced during reassembly. Refer to Figure 2 on page 2.

1. Apply Loctite PST thread sealant to seat (4) and assemble to cover with maximum torque of 10 ft-lbs; DO NOT OVER-TORQUE.
2. Assemble lever frame (3) to cover over locating pin (21) in cover. Secure with screws (8) and washers (30).
3. Install new orifice button (11) flush to arm (22). Assemble lockwasher (34) and locknut (18) over orifice button but do not tighten.
4. Connect arms (10 & 22) and assemble to lever frame (3) with four pivot pins (12) and retaining rings (13); rings should snap over pins.
5. Adjust orifice button (11) so that orifice button arm (22) slopes away from cover about 1/16" when resting gently against seat (4). Secure button by tightening lockwasher (34) and nut (18).
6. Attach float (5) and guide shaft (20) by installing last pivot pin (12) into lever frame (3). Float should move freely pressing the orifice button (11) against the seat (4) when pushed upward. Verify that all retainer rings (13) are properly secured.

REASSEMBLY (Cont'd)

7. Lay new cover gasket on clean surface. Assemble gasket (6) and cover (2) over bolt holes in body (1).
8. Insert lubricated bolts (7) and tighten to the torques listed in Table 2.
9. Place valve back in service. Refer to the Installation instructions on page 2. Slowly open inlet isolation valve.

Model Number	Bolt Size	Torque (ft-lbs)
48A, 48A.2 48A.4, 48A.5	7/16"	30
49A, 49A.2 49A.4, 49A.5	1/2"	45

TABLE 2. VALVE COVER BOLT TORQUES

PARTS AND SERVICE

Parts and service are available from your local representative or the factory. Make note of the valve Size and Model No. located on the valve nameplate and contact:

Val-Matic Valve and Mfg. Corp.
905 Riverside Drive
Elmhurst, IL 60126
PH: 630 / 941-7600
FAX: 630 / 941-8042

A sales representative will quote prices for parts or arrange for service as needed.

LIMITED WARRANTY

All products are warranted to be free of defects in material and workmanship for a period of one year from the date of shipment, subject to the limitations below.

If the purchaser believes a product is defective, the purchaser shall: (a) Notify the manufacturer, state the alleged defect and request permission to return the product; (b) if permission is given, return the product with transportation prepaid. If the product is accepted for return and found to be defective, the manufacturer will, at his discretion, either repair or replace the product, f.o.b. factory, within 60 days of receipt, or refund the purchase price. Other than to repair, replace or refund as described above, purchaser agrees that manufacturer shall not be liable for any loss, costs, expenses or damages of any kind arising out of the product, its use, installation or replacement, labeling, instructions, information or technical data of any kind, description of product use, sample or model, warnings or lack of any of the foregoing. NO OTHER WARRANTIES, WRITTEN OR ORAL, EXPRESS OR IMPLIED, INCLUDING THE WARRANTIES OF FITNESS FOR A PARTICULAR PURPOSE AND MERCHANTABILITY, ARE MADE OR AUTHORIZED. NO AFFIRMATION OF FACT, PROMISE, DESCRIPTION OF PRODUCT OF USE OR SAMPLE OR MODEL SHALL CREATE ANY WARRANTY FROM MANUFACTURER, UNLESS SIGNED BY THE PRESIDENT OF THE MANUFACTURER. These products are not manufactured, sold or intended for personal, family or household purposes.



VALVE AND MANUFACTURING CORP.

905 Riverside Dr. • Elmhurst, IL 60126
Phone (630) 941-7600 • Fax (630) 941-8042
www.valmatic.com