



Western Water Constructors, Inc.
Submittal Cover

Job no. 16-05



CONTRACT NAME: Manteca WQCF Digester Improvements
SPEC SECTION: 11381 Digester Accessories
SUBMITTAL TITLE: 10 Inch Horizontal Inline Deflagration Flame Arrester- O&M
FILE NAME: 135-R1_11381-08_10 Inch Horizontal Arrester-OM
SUB #: 135
REV #: 1
CODE: 11381-08
DATE: 12/21/2017

WWC REVIEW/COMMENTS: [X] NO EXCEPTIONS [] EXCEPTIONS / DEVIATIONS AS NOTED

Previous O&M was preliminary. This resubmittal contains the final test reports.

REVIEWED BY: ST

SIGNED: [Signature]

WWC HAS REVIEWED THIS SUBMITTAL FOR CONFORMANCE WITH THE PROJECT PLANS & SPECIFICATIONS.

OWNER REVIEW:

Table with 5 columns: ITEM, DESCRIPTION, REVIEW STATUS (A, B, C, D, E). Rows include Equipment Summary Form, Data Sheet, Instruction Manual, Test Report, and Drawing.

LEGEND: A = No Exceptions Taken, B = Make Correction Noted, C = Correct & Resubmit, D = Rejected, E = Accepted for Record

OWNER COMMENTS:

REVIEWER'S NAME:

REVIEWER'S SIGNATURE:

DATE:

Section 2.11

(94407-032204)

10" Horizontal Inline Deflagration Flame Arrester

-Equipment Summary Form

- Data Sheet

-Instruction Manual

-Test Report

- Drawing



BIOGAS
SHAND & JURTS

an **L&J TECHNOLOGIES** company

EQUIPMENT SUMMARY FORM

1. EQUIPMENT ITEM 10" Horizontal Inline Degradation Flame Arrester
2. MANUFACTURER L&J Technologies
3. EQUIPMENT IDENTIFICATION NUMBER(S) 94407-032204
(maps equipment number)
4. LOCATION OF EQUIPMENT _____
5. WEIGHT OF INDIVIDUAL COMPONENTS (OVER 100 POUNDS) 194 lbs. (Approx.)

6. NAMEPLATE DATA - Horsepower _____
Amperage _____
Voltage _____
Service Factor (S.F.) _____
Speed _____
ENC Type _____
Capacity _____
Other _____
7. MANUFACTURER'S LOCAL REPRESENTATIVE
Name Misco Water
Address 27101 Burbank, Suite B, Foothill Ranch, CA, 92610
Telephone Number 949-458-5555
8. MAINTENANCE REQUIREMENTS Visual inspection annually, clean as needed

9. LUBRICANT LIST n/a

10. SPARE PARTS (recommendations) Tube bank assembly--316SS (9440-10014)

11. COMMENTS _____

94407 Horizontal Inline Deflagration Flame Arrester

The Shand & Jurs 94407 Horizontal Inline Deflagration Flame Arrester is designed to provide a positive flame stop in horizontal gas piping systems containing flammable vapors having a low flash point. The 94407 not only provides exceptional protection against propagation of fire, but also offers maximum flow capacity. It is specifically designed to prevent liquid accumulation in the tube bank assembly.

The tube bank design, consisting of a spiral-wound crimped ribbon around a solid core, maximizes flow capacity with minimum pressure drop. The standard flame arrester is Factory Mutual (FM) approved to meet the ATEX application requirements per EN 12874 and ISO 16852.

Periodic inspection, maintenance and replacement of the tube bank is easily accomplished by simply removing tie-bolts and minimally expanding the remaining jack screws. Once the upper and lower body sections are expanded, the tube bank is easily removed with the aid of a handle.

Standard body construction includes light weight cast aluminum, cast iron, ductile iron, cast steel, 304 stainless steel and 316 stainless steel body materials suitable for most environments. Tube bank is available in 304 stainless steel or 316 stainless steel as standard. A complete range of sizes from 2" [50 mm] through 12" [300 mm] are available with flat face or raised face flanges to match ANSI, EN1092 or JIS connections.

For highly corrosive applications, body and tube bank construction of Duplex SS, Hastelloy C, or Alloy 20 are available.

Temperature monitor device to be installed on unprotected side of Tube Bank.

Temperature monitor devices available. Consult Factory.

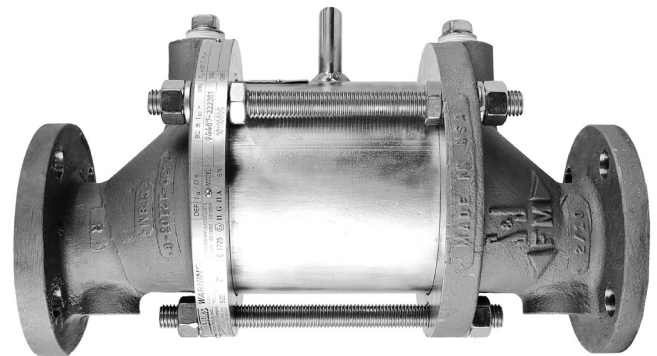

Features

- ATEX EN 12874 Approved
- ISO 16852 Approved
- Unitized tube bank design
- Maximum protection and efficiency with minimum pressure drop
- Wide range of standard construction materials
- Easy inspection and maintenance, due to simple removal of tube bank
- Complete range of flange sizes from 2" (50 mm) to 12" (300 mm) ANSI, EN1092, JIS. Consult factory for larger sizes

Specifications

Sizes:

~~2", 3", 4", 6", 8", 10" and 12"~~

Max. Static Pressure:

3.45 BARG (50 PSIG)

Max. Operating Pressure:

Sizes ~~2" - 6"~~ 1.1 BARA (16.20 PSIA)
 8"-12" 1.09 BARA (15.95 PSIA)

Max. Operating Temp:

60°C (140°F)

Flange Rating:

To match drilling of ANSI 125/150 lb. flat face, ~~raised face flange. EN1092 PN 10/16, and JIS 10K options.~~

Approval:

~~ATEX Directive 94/4/EC and EN 12874, ISO 16852 (Short Term Burn)~~

NOTE: Aluminum and Cast Iron bodies are only approved for ISO 16852.

Gas Application:

IIA (NEC Group D)

Materials of Construction

Body:

~~Carbon Steel, 304 Stainless Steel, 316 Stainless Steel, Aluminum, Cast Iron, Ductile Iron, Duplex Stainless Steel, Hastelloy C or Alloy 20~~

Hardware:

~~Carbon Steel, 304 Stainless Steel, 316 Stainless Steel, Duplex Stainless Steel, Hastelloy C or Alloy 20~~

Tube Bank:

~~Carbon Steel, 304 Stainless Steel, 316 Stainless Steel, Duplex Stainless Steel, Hastelloy C or Alloy 20~~

Gaskets:

High Temperature Synthetic Composition

Outline Dimensions

| Dimensions in Inches | | | | |
|----------------------|--------|---------|--------------|--------|
| Vent Size | "A" | "B" | Diameter "D" | "F" |
| 2" | 14 1/2 | 8 5/32 | 6 | 5/8 |
| 3" | 16 | 10 1/16 | 7 1/2 | 3/4 |
| 4" | 20 | 12 3/16 | 9 | 15/16 |
| 6" | 24 3/8 | 16 1/64 | 11 | 1 |
| 8" | 32 1/8 | 20 7/8 | 13 1/2 | 1 1/8 |
| 10" | 33 3/8 | 24 3/4 | 16 | 1 3/16 |
| 12" | 34 3/8 | 29 5/16 | 19 | 1 1/4 |

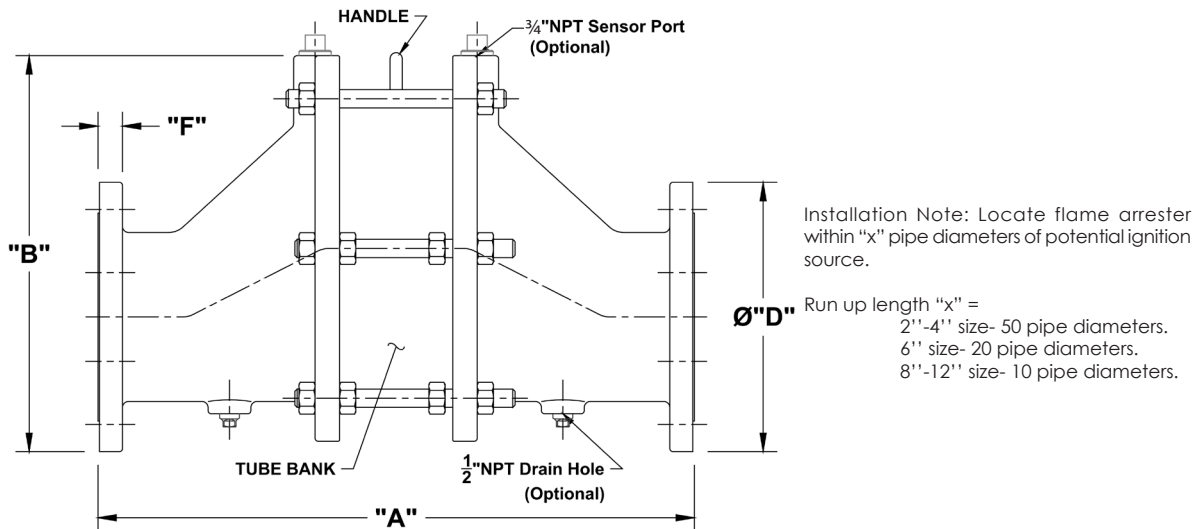

All designs subject to change. Certified dimensions and specifications available upon request.

94407 Ordering Guide

Model Number Selection

The model number will consist of a base number **94407** followed by 6 digit letters. These digits will represent 3 option tables.

94407 - AB - CD - EF

Ordering Information

Specify:

1. Model 94407 Horizontal Inline Deflagration Flame Arrester
2. Size and Body Material
3. Tube Bank and Hardware Material
4. Type of Flange and Auxillary Connection
5. Special Materials or Coatings, If Required

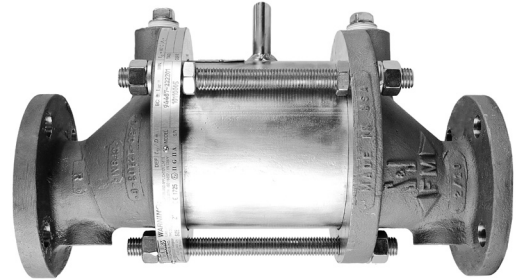

Table AB - Size & Body* Table CD - Tube Bank and Hardware*

| Option AB | Size (Inches) | Body Material | Option CD | Tube Bank Material Shell/Element | Hardware Material | Shipping Wt. (lbs) |
|-----------|---------------|---------------|-----------|---|----------------------|--------------------|
| 23 | 2 | Cast Aluminum | 00 | Carbon Steel / 304 Stainless Steel | 18-8 Stainless Steel | 15 |
| | | | 01 | Carbon Steel / 304 Stainless Steel | 304 Stainless Steel | |
| | | | 22 | 316 Stainless Steel / 316 Stainless Steel | 316 Stainless Steel | |
| 33 | 3 | Cast Aluminum | 00 | Carbon Steel / 304 Stainless Steel | 18-8 Stainless Steel | 25 |
| | | | 01 | Carbon Steel / 304 Stainless Steel | 304 Stainless Steel | |
| | | | 22 | 316 Stainless Steel / 316 Stainless Steel | 316 Stainless Steel | |
| 43 | 4 | Cast Aluminum | 00 | Carbon Steel / 304 Stainless Steel | 18-8 Stainless Steel | 45 |
| | | | 01 | Carbon Steel / 304 Stainless Steel | 304 Stainless Steel | |
| | | | 22 | 316 Stainless Steel / 316 Stainless Steel | 316 Stainless Steel | |
| 63 | 6 | Cast Aluminum | 00 | Carbon Steel / 304 Stainless Steel | 18-8 Stainless Steel | 69 |
| | | | 01 | Carbon Steel / 304 Stainless Steel | 304 Stainless Steel | |
| | | | 22 | 316 Stainless Steel / 316 Stainless Steel | 316 Stainless Steel | |
| 83 | 8 | Cast Aluminum | 00 | Carbon Steel / 304 Stainless Steel | 18-8 Stainless Steel | 93 |
| | | | 01 | Carbon Steel / 304 Stainless Steel | 304 Stainless Steel | |
| | | | 22 | 316 Stainless Steel / 316 Stainless Steel | 316 Stainless Steel | |
| 03 | 10 | Cast Aluminum | 00 | Carbon Steel / 304 Stainless Steel | 18-8 Stainless Steel | 165 |
| | | | 01 | Carbon Steel / 304 Stainless Steel | 304 Stainless Steel | |
| | | | 22 | 316 Stainless Steel / 316 Stainless Steel | 316 Stainless Steel | |
| 13 | 12 | Cast Aluminum | 00 | Carbon Steel / 304 Stainless Steel | 18-8 Stainless Steel | 200 |
| | | | 01 | Carbon Steel / 304 Stainless Steel | 304 Stainless Steel | |
| | | | 22 | 316 Stainless Steel / 316 Stainless Steel | 316 Stainless Steel | |

*NOTE: Aluminum and Cast Iron bodies are only ISO 16852 approved.
 Raised Face not available in Aluminum bodies. Other material combinations available.

Table AB - Size & Body* Table CD - Tube Bank and Hardware*

| Option AB | Size (Inches) | Body Material | Option CD | Tube Bank Material Shell/Element | Hardware Material | Shipping Wt. (lbs) | |
|-----------|---------------|-------------------------|-----------|---|----------------------|--------------------|-----|
| 25, 24 | 2 | Cast Iron, Ductile Iron | 00 | Carbon Steel / 304 Stainless Steel | 18-8 Stainless Steel | 43 | |
| | | | 01 | Carbon Steel / 304 Stainless Steel | 304 Stainless Steel | | |
| | | | 22 | 316 Stainless Steel / 316 Stainless Steel | 316 Stainless Steel | | |
| 20 | 2 | Cast Steel | 00 | Carbon Steel / 304 Stainless Steel | 18-8 Stainless Steel | | |
| | | | 01 | Carbon Steel / 304 Stainless Steel | 304 Stainless Steel | | |
| | | | 22 | 316 Stainless Steel / 316 Stainless Steel | 316 Stainless Steel | | |
| 22 | 2 | Cast 316 SS | 22 | 316 Stainless Steel / 316 Stainless Steel | 316 Stainless Steel | | |
| 35, 34 | 3 | Cast Iron, Ductile Iron | 00 | Carbon Steel / 304 Stainless Steel | 18-8 Stainless Steel | | 65 |
| | | | 01 | Carbon Steel / 304 Stainless Steel | 304 Stainless Steel | | |
| | | | 22 | 316 Stainless Steel / 316 Stainless Steel | 316 Stainless Steel | | |
| 30 | 3 | Cast Steel | 00 | Carbon Steel / 304 Stainless Steel | 18-8 Stainless Steel | | |
| | | | 01 | Carbon Steel / 304 Stainless Steel | 304 Stainless Steel | | |
| | | | 22 | 316 Stainless Steel / 316 Stainless Steel | 316 Stainless Steel | | |
| 32 | 3 | Cast 316 SS | 22 | 316 Stainless Steel / 316 Stainless Steel | 316 Stainless Steel | | |
| 45, 44 | 4 | Cast Iron, Ductile Iron | 00 | Carbon Steel / 304 Stainless Steel | 18-8 Stainless Steel | 120 | |
| | | | 01 | Carbon Steel / 304 Stainless Steel | 304 Stainless Steel | | |
| | | | 22 | 316 Stainless Steel / 316 Stainless Steel | 316 Stainless Steel | | |
| 40 | 4 | Cast Steel | 00 | Carbon Steel / 304 Stainless Steel | 18-8 Stainless Steel | | |
| | | | 01 | Carbon Steel / 304 Stainless Steel | 304 Stainless Steel | | |
| | | | 22 | 316 Stainless Steel / 316 Stainless Steel | 316 Stainless Steel | | |
| 42 | 4 | Cast 316 SS | 22 | 316 Stainless Steel / 316 Stainless Steel | 316 Stainless Steel | | |
| 65, 64 | 6 | Cast Iron, Ductile Iron | 00 | Carbon Steel / 304 Stainless Steel | 18-8 Stainless Steel | | 207 |
| | | | 01 | Carbon Steel / 304 Stainless Steel | 304 Stainless Steel | | |
| | | | 22 | 316 Stainless Steel / 316 Stainless Steel | 316 Stainless Steel | | |
| 60 | 6 | Cast Steel | 00 | Carbon Steel / 304 Stainless Steel | 18-8 Stainless Steel | | |
| | | | 01 | Carbon Steel / 304 Stainless Steel | 304 Stainless Steel | | |
| | | | 22 | 316 Stainless Steel / 316 Stainless Steel | 316 Stainless Steel | | |
| 62 | 6 | Cast 316 SS | 22 | 316 Stainless Steel / 316 Stainless Steel | 316 Stainless Steel | | |
| 85, 84 | 8 | Cast Iron, Ductile Iron | 00 | Carbon Steel / 304 Stainless Steel | 18-8 Stainless Steel | 280 | |
| | | | 01 | Carbon Steel / 304 Stainless Steel | 304 Stainless Steel | | |
| | | | 22 | 316 Stainless Steel / 316 Stainless Steel | 316 Stainless Steel | | |
| 80 | 8 | Cast Steel | 00 | Carbon Steel / 304 Stainless Steel | 18-8 Stainless Steel | | |
| | | | 01 | Carbon Steel / 304 Stainless Steel | 304 Stainless Steel | | |
| | | | 22 | 316 Stainless Steel / 316 Stainless Steel | 316 Stainless Steel | | |
| 82 | 8 | Cast 316 SS | 22 | 316 Stainless Steel / 316 Stainless Steel | 316 Stainless Steel | | |

*NOTE: Aluminum and Cast Iron bodies are only ISO 16852 approved.
 Raised Face not available in Aluminum bodies. Other material combinations available.

Table AB - Size & Body* Table CD - Tube Bank and Hardware*

| Option AB | Size (Inches) | Body Material | Option CD | Tube Bank Material Shell/Element | Hardware Material | Shipping Wt. (lbs) | |
|-----------|---------------|-------------------------|-----------|---|----------------------|--------------------|-----|
| 05, 04 | 10 | Cast Iron, Ductile Iron | 00 | Carbon Steel / 304 Stainless Steel | 18-8 Stainless Steel | 480 | |
| | | | 01 | Carbon Steel / 304 Stainless Steel | 304 Stainless Steel | | |
| | | | 22 | 316 Stainless Steel / 316 Stainless Steel | 316 Stainless Steel | | |
| 00 | 10 | Cast Steel | 00 | Carbon Steel / 304 Stainless Steel | 18-8 Stainless Steel | | |
| | | | 01 | Carbon Steel / 304 Stainless Steel | 304 Stainless Steel | | |
| | | | 22 | 316 Stainless Steel / 316 Stainless Steel | 316 Stainless Steel | | |
| 02 | 10 | Cast 316 SS | 22 | 316 Stainless Steel / 316 Stainless Steel | 316 Stainless Steel | | |
| 15, 14 | 12 | Cast Iron, Ductile Iron | 00 | Carbon Steel / 304 Stainless Steel | 18-8 Stainless Steel | | 610 |
| | | | 01 | Carbon Steel / 304 Stainless Steel | 304 Stainless Steel | | |
| | | | 22 | 316 Stainless Steel / 316 Stainless Steel | 316 Stainless Steel | | |
| 10 | 12 | Cast Steel | 00 | Carbon Steel / 304 Stainless Steel | 18-8 Stainless Steel | | |
| | | | 01 | Carbon Steel / 304 Stainless Steel | 304 Stainless Steel | | |
| | | | 22 | 316 Stainless Steel / 316 Stainless Steel | 316 Stainless Steel | | |
| 12 | 12 | Cast 316 SS | 22 | 316 Stainless Steel / 316 Stainless Steel | 316 Stainless Steel | | |

*NOTE: Aluminum and Cast Iron bodies are only ISO 16852 approved.
Raised Face not available in Aluminum bodies. Other material combinations available.

Table E - Flange Type

| Option E | Description |
|----------|---------------------|
| 0 | ANSI 125/150lb. FF |
| 1 | ANSI 125/150lb. RF* |
| 2 | EN1092 PN10 FF |
| 3 | EN1092 PN10 RF* |
| 4 | EN1092 PN16 FF |
| 5 | EN1092 PN16 RF* |
| 6 | FF JIS 10K FF |
| 7 | JIS 10K RF* |
| 8 | Special Drilling |

*Raised Face Flanges Not Available in Aluminum.

Tube Banks Only*

| Part Number | Size (Inches) | Tube Bank Material Shell/Element | Shipping Wt. (lbs.) |
|-------------|---------------|----------------------------------|---------------------|
| 9440-10000 | 2 | Steel / 304 SS | 22 |
| 9440-10010 | | 316 SS / 316 SS | 25 |
| 9440-10001 | 3 | Steel / 304 SS | 30 |
| 9440-10011 | | 316 SS / 316 SS | 35 |
| 9440-10002 | 4 | Steel / 304 SS | 55 |
| 9440-10012 | | 316 SS / 316 SS | 60 |
| 9440-10003 | 6 | Steel / 304 SS | 90 |
| 9440-10013 | | 316 SS / 316 SS | 100 |
| 9440-10004 | 8 | Steel / 304 SS | 145 |
| 9440-10014 | | 316 SS / 316 SS | 160 |
| 9440-10005 | 10 | Steel / 304 SS | 225 |
| 9440-10015 | | 316 SS / 316 SS | 240 |
| 9440-10006 | 12 | Steel / 304 SS | 310 |
| 9440-10016 | | 316 SS / 316 SS | 325 |

*Other Material Combinations Available.

Table F - Auxillary Connections

| Option F | Description | Quantity |
|------------------|--|------------------|
| 0 ⁽¹⁾ | 3/4" NPT (Uni-Directional) | 1 |
| 1 | 3/4" NPT (Bi-Directional) | 2 |
| 2 | 3/4" NPT (Bi-Directional) | 4 |
| 4 | 3/4" NPT (U) ⁽²⁾ w/1/2" NPT (Drain) | 3 ⁽³⁾ |
| 5 | 3/4" NPT (B) ⁽²⁾ w/1/2" NPT (Drain) | 4 ⁽³⁾ |
| 6 | 3/4" NPT (B) ⁽²⁾ w/1/2" NPT (Drain) | 6 ⁽³⁾ |

- Flow Direction Label Affixed to Cast Body.
- U = Uni-Directional; B = Bi-Directional.
- Includes two drain connections - one per side.

SAFETY INFORMATION

Before proceeding, any addendum along with the instruction manual must be fully read and understood. Periodically throughout this manual, the words Danger, Warning, Caution and Note may occur. These are reminders to be especially careful. See the descriptions below for more details on what each word denotes.

⚠ DANGER

Indicates an imminently hazardous situation which, if not avoided, "will" result in death or serious injury. This word is limited to the most extreme situations.

⚠ WARNING

Indicates a potentially hazardous situation which, if not avoided, "could" result in death or serious injury.

⚠ CAUTION

Indicates a potentially hazardous situation which, if not avoided, "may" result in minor or moderate injury, or damage to the instrument being worked on.

! **Note:** Is meant to add some measure of help or give useful information to the person working on the instrument.

⚠ WARNING

As with all safety devices, the flame arrester must be installed and maintained by a knowledgeable technician. Carefully read and understand this manual before installing or servicing this product

⚠ WARNING

It is important to take the following precautions before you start work on the flame arrester.

1. Personnel installing or performing maintenance to the flame arrester must be competent and utilize approved equipment and clothing normally used to work with the process media where the flame arrester is installed.
2. The tank the flame arrester is installed must be at atmospheric pressure conditions and free of hazardous vapors.
3. Handling of the flame arrester must be done by personnel trained in all aspects of manual and mechanical handling techniques.
4. Flame arrester must be properly sized for tank conditions. Incorrect sizing can result in tank and or flame arrester destruction.

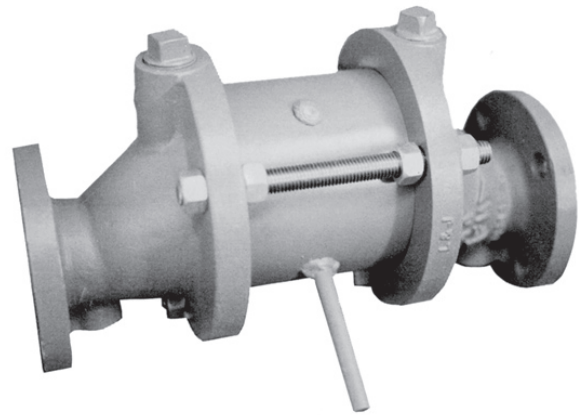

FIGURE 1: MODEL 94407 DEFLAGRATION FLAME ARRESTER

GENERAL

This Shand & Jurs 94406 (Vertical) and 94407 (Horizontal) Deflagration Flame Arrester act as an in line or end of line safety device designed to prevent the transmission of a deflagration (flame propagation) between flammable liquids stored in low pressure tanks and their emitted combustible vapors. This barrier provides protection from damage to the complete system caused by the deflagration pressures created by gas/vapor ignition in another part of the system.

The 94406 and 94407 Deflagration Flame Arresters are safety devices designed to keep the temperature of the flammable vapor passing through the arrester's tube bank below its flash point thereby preventing combustion. The tube bank consists of alternating flat and corrugated sheet stock spiral-wound around a solid core. It is contained in a shell that is positioned between the arrester's body sections. Tie bolts, lock washers and nuts are used to secure the body sections to the tube bank. When the tube bank assembly is to be removed for cleaning, periodic inspection or maintenance, the tie bolts are used as jacking screws to separate the body sections to permit removal.

The deflagration flame arrester has been designed and tested for specified operating conditions, which must be maintained to ensure proper protection. The standard flame arrester is Factory Mutual (FM) approved to meet the ATEX application requirements per EN 12874 and ISO 16852. These requirements include a short time burn test.

These arresters are not suitable for sustaining a continuous flame, and therefore are required to have a flame monitoring system that will indicate burning and terminate vapor flow within 50% of rated burn time in accordance with ISO 12874 or within 1 minute for EN12874. In addition to providing exceptional protection against fire and explosion from an external ignitable source, it also allows maximum free flow of vapor with minimum pressure drop.

WARNING

The lifting handle(s) provided on the tube bank should not be used for lifting the entire Flame Arrester. These handles permit ease of handling the tube bank only for inspection and maintenance.

RECEIVING

This shipment is the property of the purchaser when it leaves our plant. Shand & Jurs cannot be responsible for any damage or loss during transit. Any claim must be reported to the transportation company. If a shipment is received incomplete or damaged, notify the transportation company at once, preserve shipping crate, packing slip and contents as received. Failure to properly describe evidence of loss or damage to carrier may result in the carrier refusing to honor claim.

Shand & Jurs shipping procedures have been proven by years of experience. Your equipment is thoroughly inspected before leaving our plant and is carefully crated in compliance with carrier regulations. The carrier contracted, assumes responsibility for delivery upon acceptance of shipment.

MODEL NUMBER IDENTIFICATION

Your equipment is identified by a Shand & Jur's model number stamped on the nameplate. Options such as material construction, raised or flat face flange and etc. are part of the Model Number. Refer to the following Model Number Breakdown to determine the options in your equipment.

NAMEPLATE TECHNICAL DATA

All Deflagration Flame Arresters as well as the Tube Bank Elements are fitted with individual nameplates that specify the following technical information:

Deflagration Flame Arresters:

1. Name and Address of Manufacturer
2. Model Designation
3. Serial Number (Including Manufacturing Year)
4. Applicable Certification Number(s)
5. EN and/or ISO Standard Number
6. Explosion Group and Sub-Group
7. All Applicable Warnings
8. Installation and Application Limits

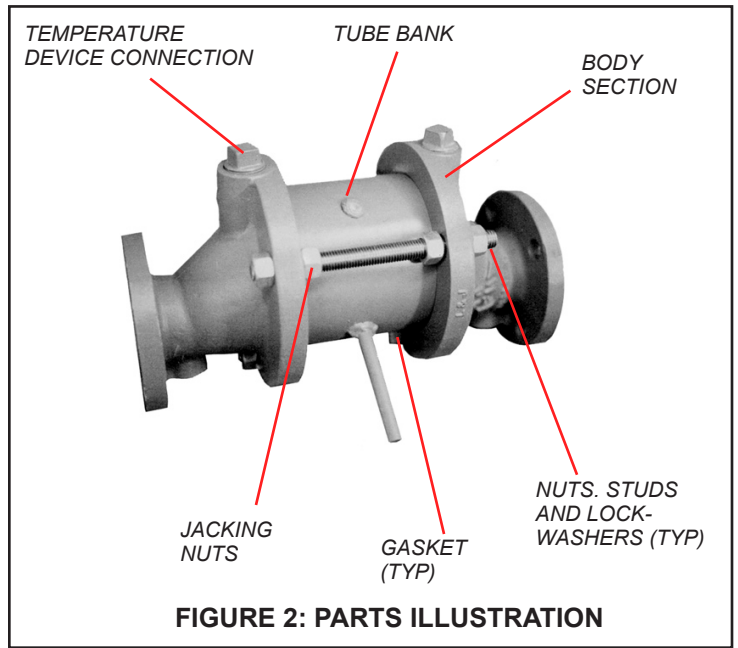

FIGURE 2: PARTS ILLUSTRATION

9. Maximum Run Up Distance
10. Operational Temperature
11. Maximum Operating Pressure

Tube Bank Elements:

1. Name and Address of Manufacturer
2. Model or Part Number Designation
3. Serial Number (Including Manufacturing Year)

When ordering replacement parts, use the complete model number, part description and its related part number. See Figure 5 for Nameplate Detail.

INSTALLATION

The flame arrester is generally installed in line or on vent pipe from storage or processing tanks, bleed lines, bleed tanks or other waste gas devices. The flange of the flame arrester is either a flat face or raised face. When mounting a raised face flange, be extremely careful when tightening its mounting bolts so flange does not crack. Refer to dimensions of arrester to be installed making sure sufficient clearance is allowed to enable tube bank to be removed. Mount arrester as follows.

1. Remove vent cover or others (if present) from tank nozzle or vent pipe on which arrester is to be mounted. Discard old flange gasket.
2. Place new gasket on tank nozzle or vent pipe. Cut away any gasket material that may extend into vapor flow passage.
3. Place arrester over new gasket. Position arrester so the mounting holes are aligned and its handle is accessible enabling tube bank to be removed for maintenance or replacement.
4. Bolt arrester securely in place using alternating tightening pattern.
5. If required, attach free vent, breather valve or others

SHAND & JURS

Deflagration Flame Arrester

MODEL NUMBER & OPTION DESCRIPTIONS

94406 -

***94407 - AB - CD - EF**

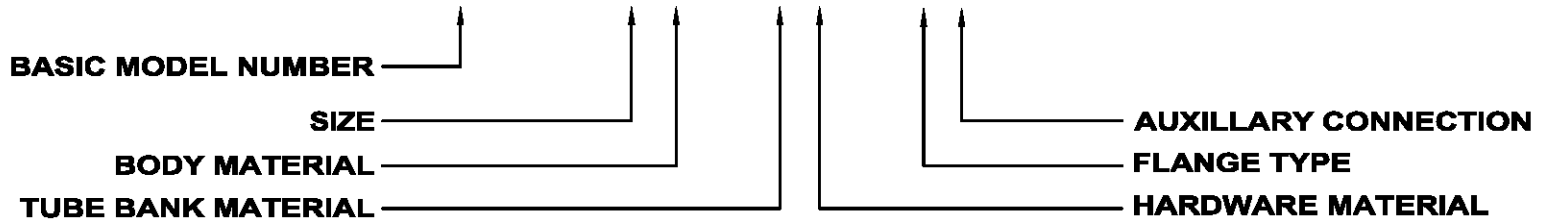

TABLE I (A) - SIZE

| OPTION # | SIZE |
|----------|------|
| 2 | 2" |
| 3 | 3" |
| 4 | 4" |
| 6 | 6" |
| 8 | 8" |
| 0 | 10" |
| 1 | 12" |

TABLE I (B) - BODY MATERIAL (ASTM)

| OPTION # | MATERIAL |
|----------|---|
| 0 | CARBON STEEL (A216 Gr WCB) |
| 1 | 304 STAINLESS STEEL (A351 Gr CF8) |
| 2 | 316 STAINLESS STEEL (A351 Gr CF8M) |
| 3 | ALUMINUM [ISO ONLY] (B26 ALLOY 356-T51) |
| 4 | DUCTILE IRON (A536 Gr 65-45-12) |
| 5 | CAST IRON [ISO ONLY] (A48 CI 40A) |
| 6 | DUPLEX STAINLESS STEEL (A890 Gr 4A) |
| 7 | HASTELLOY C (A494 Gr CW-2M) |
| 8 | ALLOY 20 (A743 Gr CN7M) |

NOTE: ALUMINUM AND CAST IRON BODIES ARE ONLY ISO APPROVED

TABLE II (C) - TUBE BANK MATERIAL

| OPTION # | SHELL/ELEMENT |
|----------|----------------------------------|
| 0 | CARBON STEEL/304 STAINLESS STEEL |
| 1 | 304 STAINLESS STEEL (ALL) |
| 2 | 316 STAINLESS STEEL (ALL) |
| 4 | CARBON STEEL/316 STAINLESS STEEL |
| 6 | DUPLEX STAINLESS STEEL (ALL) |
| 7 | HASTELLOY C (ALL) |
| 8 | ALLOY 20 (ALL) |

TABLE II (D) - HARDWARE MATERIAL

| OPTION # | DESCRIPTION |
|----------|----------------------------|
| 0 | CARBON STEEL (ZINC PLATED) |
| 1 | 304 STAINLESS STEEL |
| 2 | 316 STAINLESS STEEL |
| 6 | DUPLEX STAINLESS STEEL |
| 7 | HASTELLOY C |
| 8 | ALLOY 20 |

TABLE III (E) - FLANGE TYPE

| OPTION # | DESCRIPTION |
|----------|---------------------|
| 0 | FF ANSI 125#/150# |
| 1 | * RF ANSI 125#/150# |
| 2 | FF DIN PN10 |
| 3 | * RF DIN PN10 |
| 4 | FF DIN PN16 |
| 5 | * RF DIN PN16 |
| 6 | FF JIS 10K |
| 7 | * RF JIS 10K |
| 8 | SPECIAL DRILLING |

* RAISED FACE FLANGES NOT AVAILABLE WITH ALUMINUM BODIES

TABLE III (F) - AUXILLARY CONNECTIONS

| OPTION # | DESCRIPTION | QUANTITY |
|----------|-------------------------------|----------|
| 0 * | 3/4" NPT (UNI-DIRECTIONAL) | 1 |
| 1 | 3/4" NPT (BI-DIRECTIONAL) | 2 |
| 2 | 3/4" NPT (BI-DIRECTIONAL) | 4 |
| 3 | 3/4" NPT (BI-DIRECTIONAL) | 6 |
| **4* | 3/4" NPT (U) + 1/2"NPT(DRAIN) | 1 + 2 |
| **5 | 3/4" NPT (B) + 1/2"NPT(DRAIN) | 2 + 2 |
| **6 | 3/4" NPT (B) + 1/2"NPT(DRAIN) | 4 + 2 |
| **7 | 3/4" NPT (B) + 1/2"NPT(DRAIN) | 6 + 2 |

NOTE: 1. * FLOW DIRECTION LABEL AFFIXED TO CAST BODY
 2. U = UNI-DIRECTIONAL; B = BI-DIRECTIONAL
 3. ** DESIGNATES 94407 OPTIONS ONLY

*** THE 94407 IS DESIGNED FOR HORIZONTAL INSTALLATIONS**

onto top of arrester using instruction manual supplied with unit.

WARNING

The installation of the Deflagration Flame Arrester requires that a flame detection system be used to determine the presence of a flame front at the flame arrester element. Once the flame has been detected, all transmission of vapor through the pipeline must be stopped so the continuous burning of combustible mixture does not occur on the surface of the element. Although the Deflagration Flame Arrester is designed to meet short burn test requirements, prolonged burning is not recommended. After the vapor has stopped flowing through the flame arrester and the flame detection system no longer indicates any elevated temperatures, the flame arrester must be isolated and inspected for any possible damage cause by the flame front. Any tube bank element that appears to be damaged or distorted must be immediately replaced to prevent any potential flashback or flame propagation into the piping or system, causing severe damage.

MAINTENANCE

Inspect the bank at least once a month for the first year after installation and clean the tube bank whenever inspection shows the need.

These inspections and the frequency of cleaning will provide the basis to establish a predetermined maintenance program.

WARNING

1. Before performing any maintenance, the inside of the storage tank or vent line must be at atmospheric pressure and free of hazardous atmosphere.
2. If tube bank is damaged, the tube bank must be replaced as a complete assembly. Under no circumstance should the tube bank be disassembled for cleaning or replacement.

1. Remove pressure in storage tank or line containing flammable liquid to atmosphere.
2. Remove tie bolts without jacking nuts.
3. Turn jacking nuts, each a little at a time to evenly separate the body sections of flame arrester. Continue turning jacking nuts in this manner until there is just enough clearance to free tube bank from upper body section. Refer to assembly drawing.
4. Grasp handle on tube bank and slowly pull forward until approximately three quarters of tube bank is exposed. Do not completely remove tube bank from arrester. Leave tube bank in far enough permitting lower body section to support weight of tube bank.

5. Inspect for dirt, tar, gum or other residues clogging tube bank corrugations. If tube bank must be cleaned, refer to Cleaning section below.

CLEANING

Inspect corrugations of tube bank to determine type of residue clogging it. Use one of the following procedures: A, B or C that list clogging substance to clean tube bank. If suggested procedure is not successful, check to see if substance is also listed in another procedure.

WARNING

When substance is not removed using a particular procedure, replace with new tube bank to avoid risk of damage to tank and possible loss of product since clogging prevents tank venting.

WARNING

Handle volatile and flammable solvents with care to avoid ignition or prolonged breathing.

CLEANING PROCEDURE A

Clogging Substances:

Soil, sand, pollen and metallic salts.

Cleaning Method:

1. Wash with mild solvent such as kerosene, gasoline, petroleum naphtha, or commercial petroleum derived cleaning fluids.
2. Rinse in a solvent that will not leave an oily film which can collect foreign matter.
3. Use compressed air to blow-out substance from tube bank.
4. Wash with hot water.
5. Steam clean.

CLEANING PROCEDURE B

Clogging Substances

Metallic oxides and metallic carbonates.

Cleaning Method

1. Perform step 1 of Cleaning Procedure A.
2. Soak the tube bank in cold 35% nitric acid only if tube bank and shell assemblies are all Hastelloy, Alloy 20 or stainless steel. Nitric acid quickly destroys carbon steel.

If clogging substance is still present, place tube bank in boiling 35% nitric acid.

WARNING

Use protective clothing and gloves when using acid. Serious burns will result when acid contacts skin.

3. After tube bank is clean, submerge in a solution of baking soda and water (8 ounces of baking soda to 3 gallons of water) to neutralize any acid remaining on tube bank.
4. Blow dry using compressed air.

CLEANING PROCEDURE C

Clogging Substances:

Organic tars, organic gums and organic or sulphur residues.

Cleaning Method

1. Perform step 1 of Cleaning Procedure A.
2. Blow out with compressed air.
3. Wash with a strong solvent such as benzol, xylol, carbon tetrachloride, acetone, carbon disulphide, paint thinner (not lacquer thinner), or a mixture of 1/3 each of benzol, alcohol and acetone.

REMOVAL AND REPLACEMENT

The tube bank is secured between the gasketed body sections of the flame arrester with tie-bolts. Some of the tie-bolts are fitted with jacking nuts to separate the body sections of the flame arrester thereby allowing the tube bank to be removed.

1. Make sure vapor pressure in the storage tank or line is at atmospheric pressure and free of hazardous atmosphere.
2. Remove tie-bolts without jacking nuts.
3. Turn jacking nuts, each a little at a time to evenly separate the body sections of flame arrester. Continue turning jacking nuts in this manner until there is just enough clearance to free tube bank from upper body section. Refer to assembly drawing.
4. Remove tube bank from a small flame arrester (flange sizes 2-inch thru 8-inch), by grasping tube bank handle and pulling forward until tube bank is free from flame arrester. On larger flame arresters (flange sizes 10-inch and 12-inch) use adequate equipment or manpower to remove tube bank.

CAUTION

The 10-inch and 12-inch tube banks weigh more than 185 lbs. Failure to use adequate equipment such as a portable hoist or adequate manpower may cause injury to persons or property.

WARNING

When removing or installing the tube bank exercise extreme care not to damage corrugated sheet stock inside tube bank.

5. Exercise caution when removing the tube bank element not to damage each of the gaskets between the tube bank shell and the flame arrester body. With the tube bank assembly removed, inspect the gasket for any damage. Replace if necessary.
6. Insert new tube bank or one that has been cleaned in the reverse order as removed. Again exercise care not to damage corrugations inside tube bank.
7. Ensure that the gaskets between the tube bank element and bodies are properly positioned before tightening the tie rods and nuts. Tighten all nuts evenly and in a uniform alternating tightening pattern.
8. After the flame arrester has been reassembled and installed in the pipeline, a static pressure test should be performed to verify the reassembly and installation are leak free.

PARTS LIST

Order parts through the nearest Shand & Jurs office, representatives or distributor or direct from our factory.

When ordering replacement parts, be sure to use the complete equipment model number, description of the part being ordered and its related part number. Make sure the model number contains all option numbers as described in the Model Number Identification Paragraph.

TEMPERATURE MONITOR RECOMMENDATIONS

The safe operation of the 94406/94407 Deflagration Flame Arresters require the use of a temperature probe(s) (user supplied) that will give immediate indication of the ignition of vapors and provide verification of a flame front at the flame arrester element. The response time should be 15 seconds or less. The lengths provided are measured from the top of the 3/4" NPT connection to the location for the end of the probe. The recommended temperature probe length for each model is as follows:

Model: 94406

Size Length

2": 2-1/2"

3": 3-1/2"

4": 4"

6": 5"

8": 6"

10": 7"

12": 9"

Model: 94407

Size Length

2": 2-1/2"

3": 3-1/2"

4": 4"

6": 6"

8": 9"

10": 10"

12": 12"

STANDARD TUBE BANK REPLACEMENT ASSEMBLIES

| MATERIAL | | SIZE (INCHES) | PART NUMBER |
|------------------------|------------------------|------------------|-------------|
| ELEMENT | SHELL | | |
| 304 STAINLESS STEEL | CARBON STEEL | 2 | 9440-10000 |
| | | 3 | 9440-10001 |
| | | 4 | 9440-10002 |
| | | 6 | 9440-10003 |
| | | 8 | 9440-10004 |
| | | 10 | 9440-10005 |
| | | 12 | 9440-10006 |
| 316 STAINLESS STEEL | 316 STAINLESS STEEL | 2 | 9440-10010 |
| | | 3 | 9440-10011 |
| | | 4 | 9440-10012 |
| | | 6 | 9440-10013 |
| | | 8 | 9440-10014 |
| | | 10 | 9440-10015 |
| | | 12 | 9440-10016 |

*Consult factory for other materials of construction.

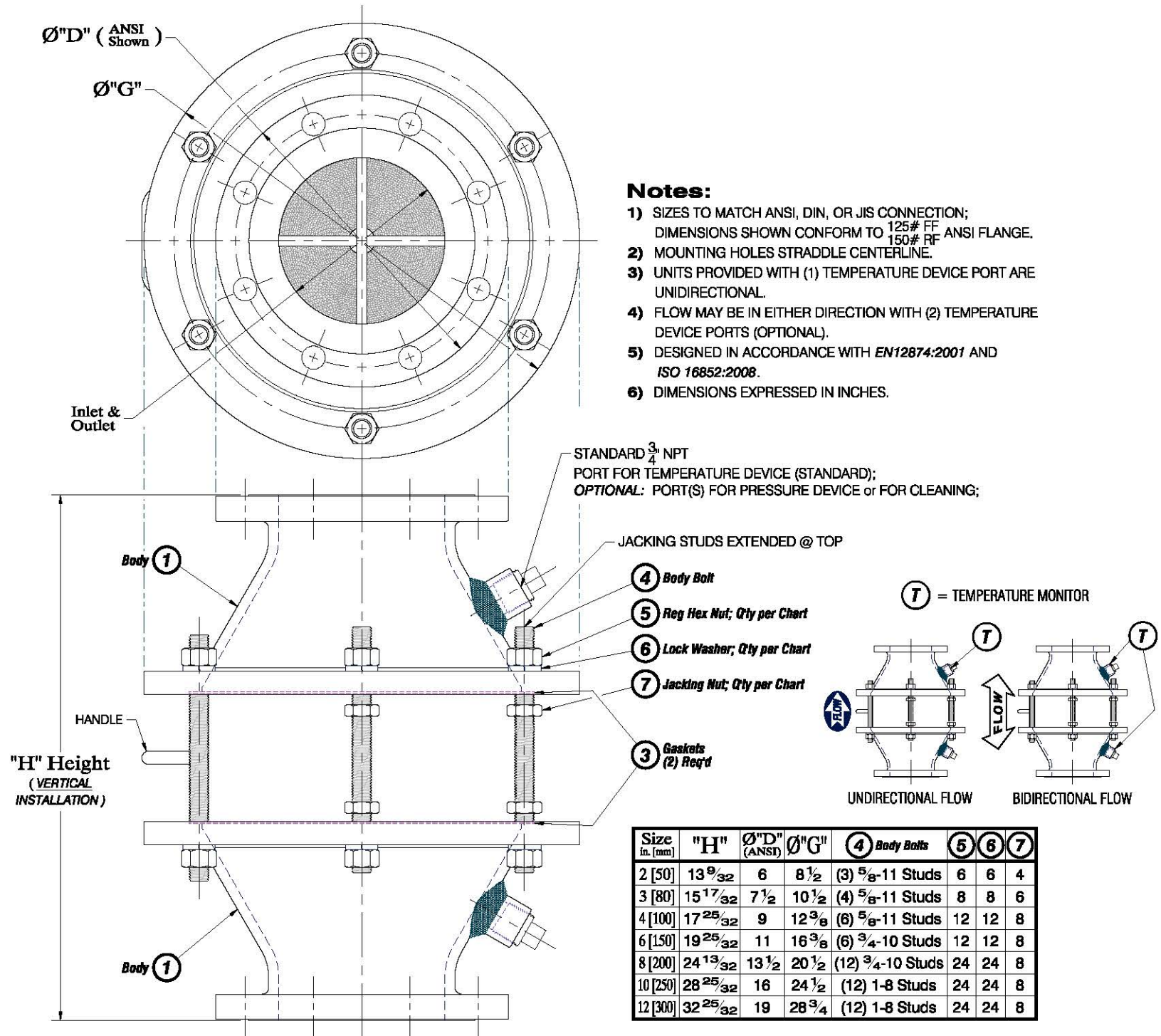

Figure 3. Model 94406 Assembly

Notes:

- 1) SIZES TO MATCH ANSI, DIN, OR JIS CONNECTION;
DIMENSIONS SHOWN CONFORM TO 125# FF
150# RF ANSI FLANGE.
- 2) MOUNTING HOLES STRADDLE CENTERLINE.
- 3) UNITS PROVIDED WITH (1) TEMPERATURE DEVICE PORT ARE
UNIDIRECTIONAL.
- 4) FLOW MAY BE IN EITHER DIRECTION WITH (2) TEMPERATURE
DEVICE PORTS (OPTIONAL).
- 5) DESIGNED IN ACCORDANCE WITH EN12874:2001 AND
ISO 16852:2008.
- 6) DIMENSIONS EXPRESSED IN INCHES.

| Size in. [mm] | "A" | "B" | Ø"D" | "H" | ④ Body Bolts | ⑤ | ⑥ | ⑦ |
|------------------|--------|---------|--------|--------|-------------------|----|----|---|
| 2 [50] | 14 1/2 | 8 3/8 | 6 | 1 1/2 | (3) 5/8-11 Studs | 6 | 6 | 4 |
| 3 [80] | 16 | 10 1/16 | 7 1/2 | 3 3/16 | (4) 5/8-11 Studs | 8 | 8 | 6 |
| 4 [100] | 20 | 12 3/16 | 9 | 4 9/16 | (6) 5/8-11 Studs | 12 | 12 | 8 |
| 6 [150] | 24 3/8 | 16 3/16 | 11 | 5 3/8 | (6) 3/4-10 Studs | 12 | 12 | 8 |
| 8 [200] | 32 7/8 | 20 7/8 | 13 1/2 | 7 1/4 | (12) 3/4-10 Studs | 24 | 24 | 8 |
| 10 [250] | 33 3/8 | 24 3/4 | 16 | 7 1/2 | (12) 1-8 Studs | 24 | 24 | 8 |
| 12 [300] | 34 3/8 | 29 5/16 | 19 | 8 | (12) 1-8 Studs | 24 | 24 | 8 |

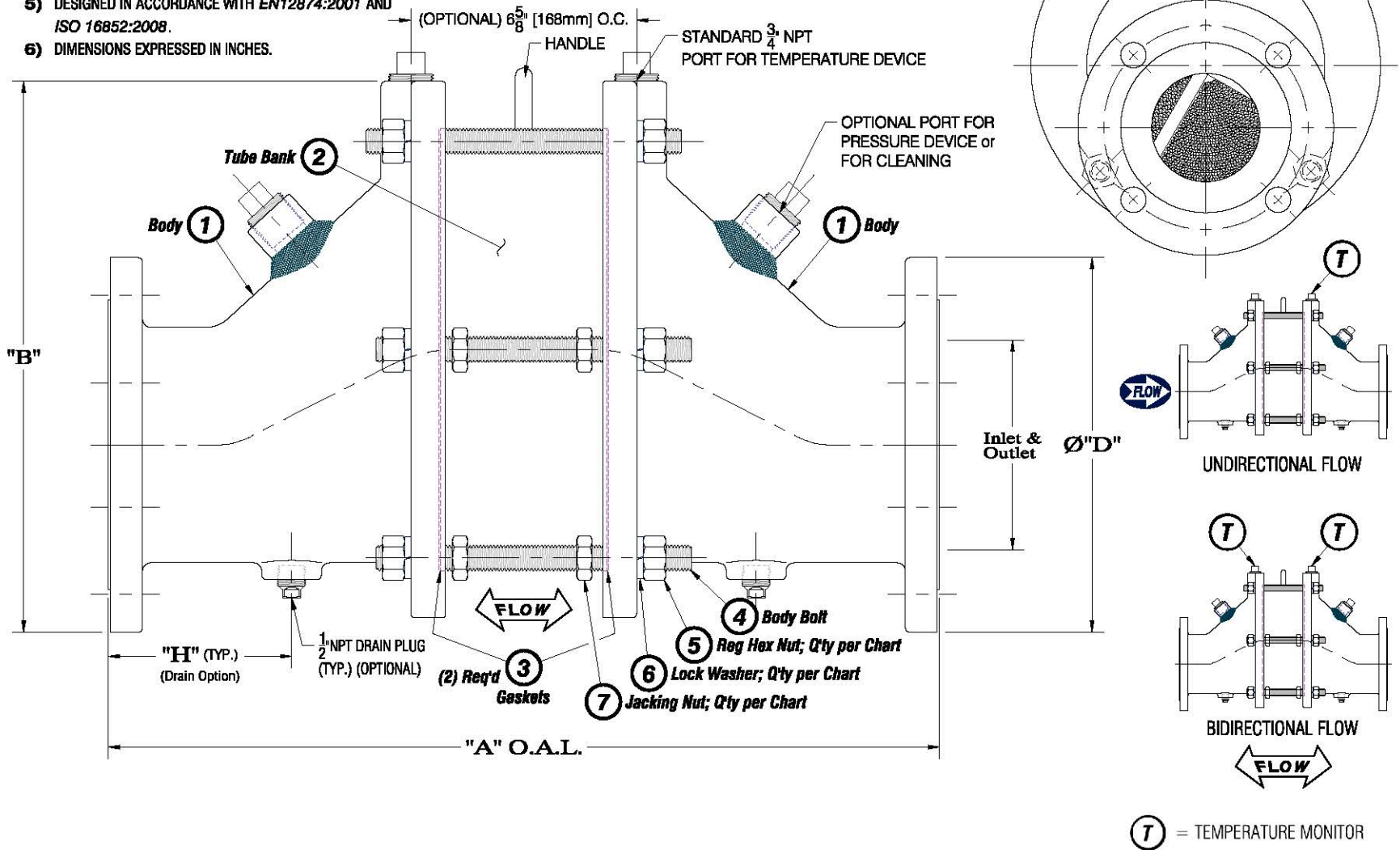



Figure 4. Model 94407 Assembly

Ⓣ = TEMPERATURE MONITOR

| | | | | | | | | |
|---|--|-------|-------------|-------------------|------|--------------------|---------|------|
|  SHAND&JURS GPE CONTROLS, INC. an <i>L&J TECHNOLOGIES</i> Company HILLSIDE, ILLINOIS USA www.ljtechnologies.com 708-236-6000 | WARNING: FLAME ARRESTERS HAVE INSTALLATION AND APPLICATION LIMITS. TYPE DESIGNATION IN ACCORDANCE WITH ISO 16852 / EN 12874 | DEF | $L_u / D =$ | BC: b; $t_{BT} =$ | MIN. | $T_o = 60^\circ C$ | $P_o =$ | BARA |
| | | ○ | MODEL: | | | | TAG: | ○ |
| | | SIZE: | CE 1725 | Ex II G IIA | S/N: | | | |

| | | | | | | | | |
|---|---|-------|----------------|-------------------|------|--------------------|---------|------|
|  SHAND&JURS GPE CONTROLS, INC. an <i>L&J TECHNOLOGIES</i> Company HILLSIDE, ILLINOIS USA www.ljtechnologies.com 708-236-6000 | WARNING: FLAME ARRESTERS HAVE INSTALLATION AND APPLICATION LIMITS. TYPE DESIGNATION IN ACCORDANCE WITH ISO 16852 | DEF | $L_u / D =$ | BC: b; $t_{BT} =$ | MIN. | $T_o = 60^\circ C$ | $P_o =$ | BARA |
| | | ○ | MODEL: | | | | TAG: | ○ |
| | | SIZE: | II G Ex. G IIA | | S/N: | | | |

TUBE BANK NAMEPLATE

| | |
|---|--|
|  SHAND&JURS GPE CONTROLS, INC. an <i>L&J TECHNOLOGIES</i> Company HILLSIDE, ILLINOIS USA www.ljtechnologies.com 708-236-6000 | |
| Flame Arrester TUBE BANK | |
| P/N: | <input type="text"/> |
| S/N: | <input type="text"/> YR: 20 <input type="text"/> |

Figure 5: Nameplate Details

This Page Intentionally Blank

SHAND&JURS

an **L&J TECHNOLOGIES** Company

All designs subject to change. Certified dimensions and specifications available upon request.

5911 Butterfield Road • Hillside, Illinois 60162
Telephone: (708) 236-6000 • Fax: (708) 236-6006

6911 Printed in U.S.A.

SHAND & JUR'S

QUALITY CONTROL TECHNICAL DATA SHEET

RA800-557

SHAND&JURS
An L&J Technologies Company

ORDER TJ2290
ITEM 09

PART#: 94407-032204

10"AL, 316/TB, 1-3/4", 2-1/2", ISO

DATE: 12/12/2017

Test Procedure:
Model 94406/94407

Deflagration Flame Arrester

GROUP: IIA

TAG#

| SERIAL# | Tube Bank, Crimp, Gaps Tightness, Shell | 145 PSI Leak Test | Final 50 PSI Leak Test | Dimension & Label Marking | REL FOR SHIP |
|----------|---|----------------------|---------------------------|---------------------------------|--------------------|
| 17502031 | P | P | P | P | MG |

TESTED BY SIFUENTES

SHAND & JURS

QUALITY CONTROL TECHNICAL DATA SHEET

RA800-557

SHAND&JURS
An L&J Technologies Company

ORDER TJ2290
ITEM 09

PART#: 94407-032204

10"AL, 316/TB, 1-3/4", 2-1/2", ISO

DATE: 12/12/2017

Test Procedure:
Model 94406/94407

Deflagration Flame Arrester

GROUP: IIA

TAG#

| SERIAL# | Tube Bank, Crimp, Gaps Tightness, Shell | 145 PSI Leak Test | Final 50 PSI Leak Test | Dimension & Label Marking | REL FOR SHIP |
|----------|---|----------------------|---------------------------|---------------------------------|--------------------|
| 17502032 | P | P | P | P | MG |

TESTED BY SIFUENTES

9440-00020-10-TJ2290

T:\SO#\TXXXXX\TJ2290\9440-00020-10-TJ2290.DWG

THIS DISCLOSURE IS THE PROPERTY OF SHAND & JUR'S, IS SUBJECT TO RETURN UPON DEMAND, AND IS MADE WITH THE UNDERSTANDING THAT IT IS NOT TO BE REPRODUCED, COPIED OR USED, DIRECTLY OR INDIRECTLY, IN ANY WAY DETRIMENTAL TO THE INTERESTS OF SHAND & JUR'S, OR WITHOUT THE EXPRESS APPROVAL OF SHAND & JUR'S.

REMOVABLE STUDS MUST STRADDLE TUBE BANK HANDLE

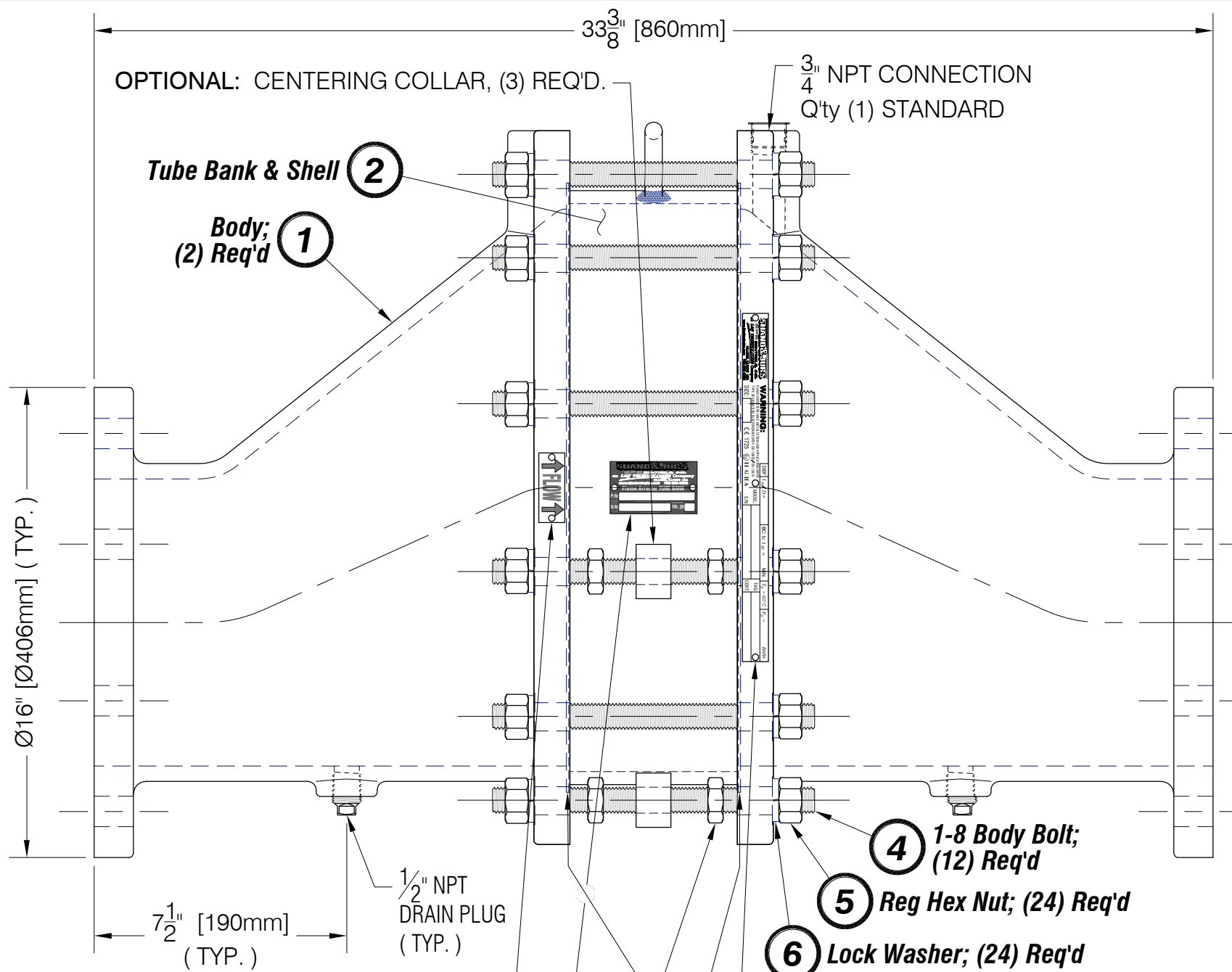
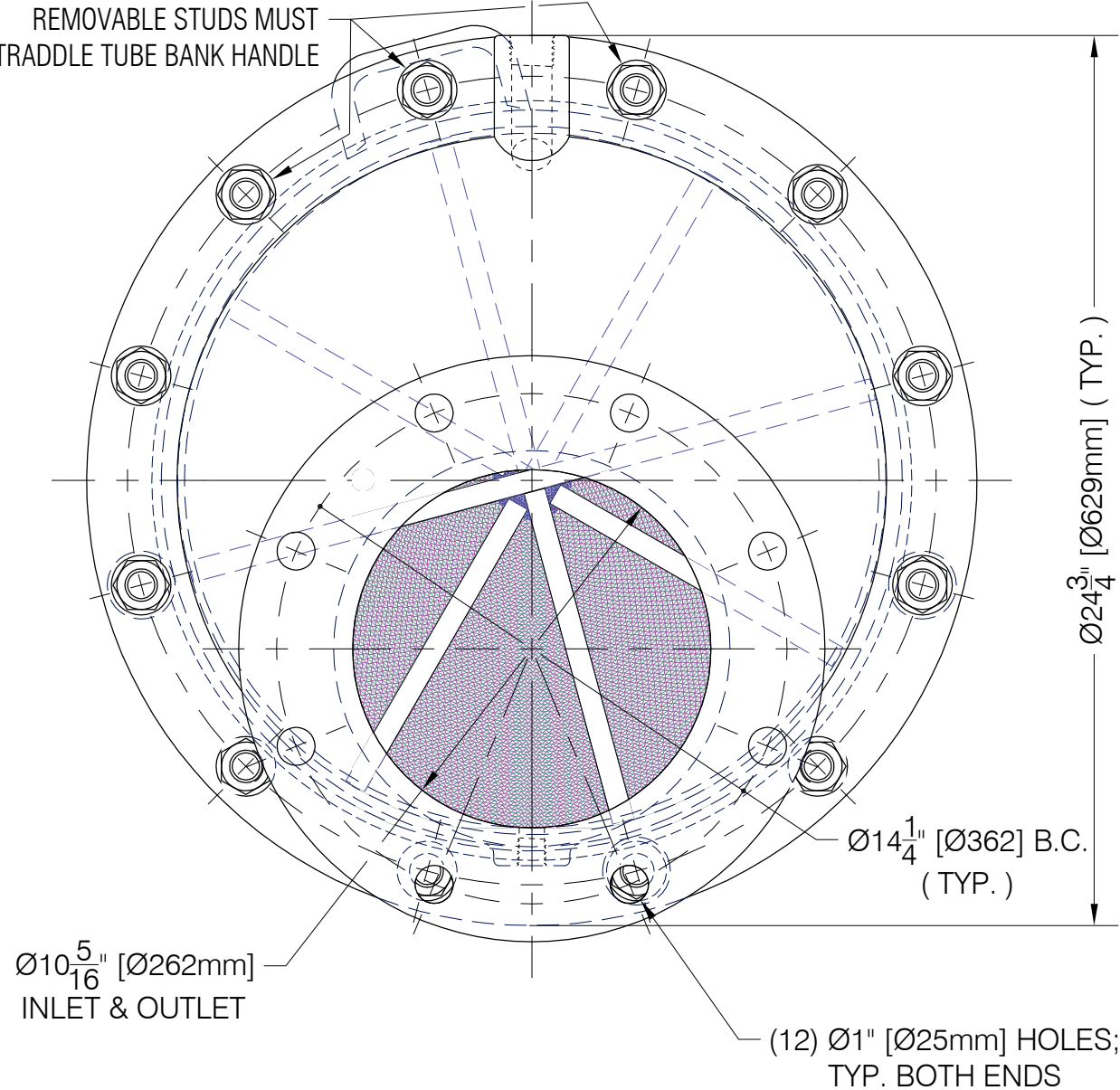

Notes:

- 1) MOUNTING DIMENSIONS MATCH 125# FF ANSI FLANGE CONNECTION.
- 2) MOUNTING HOLES STRADDLE CENTERLINE.
- 3) FLOW IS UNIDIRECTIONAL.
- 4) DESIGNED IN ACCORDANCE WITH EN12874:2001 AND ISO 16852:2008.
- 5) DIMENSIONS EXPRESSED IN INCHES [millimeters].

Materials of Construction:

- Body Castings: B26-356 Aluminum
- Tube Bank Shell: ASTM A240-T316 S.S.
- T/B Element: ASTM A240-T316 S.S.
- Body Bolts: Type 316 S.S.
- Hex & Jacking Nuts: 18-8 Stainless Steel
- Lock Washers: Type 316 S.S.
- Gaskets: Hi-Temp "Garlock" #9850

Cust. Tag No('s): TBD
Quantity: 2

PROJECT: 16-05 WW QC Facility Digester Improvements
 CUSTOMER: Western Water Constructors, Inc.
 CUSTOMER P.O. NO: 1605-03
 DESCRIPTION: Horiz. Deflagration Flame Arrester
 MODEL NO: 94407-032204
 SPECIFICATION: 11381 Section 2.11
 S&J SALES ORDER NO: TJ2290 DATE: Feb 01, 2017

APPROVED APPROVED w/CHANGES NOT APPR.-RESUB. PER COMMENT
 CUST. SIGNATURE: _____ DATE: _____

| | | | | | |
|---|----------------------|---|-------|-----------|------------|
| A | Release | 6013 | SB | Oct 13 09 | RJD |
| REV | DESCRIPTION | ECO | BY | DATE | APRV |
| SHAND & JUR'S an L&J TECHNOLOGIES Company HILLSIDE, ILLINOIS USA | | | | | |
| 94407 Horiz. Deflagration Flame Arrester 10" FF Dimensions | | | | | |
| APRV/CHKD/DATE/DRWN | GP | Type: | Dim's | Size: | B: 17 x 11 |
| | Oct 13 09 | Scale: | None | Designed: | BKS |
| | BKS | T:\SO#\TXXXXX\TJ2290\9440-00020-10-TJ2290.DWG | | | |
| RJD | 9440-00020-10-TJ2290 | | | | |