



Western Water Constructors, Inc.
Submittal Cover

Job no. 16-05



CONTRACT NAME: Manteca WQCF Digester Improvements
SPEC SECTION: 11381 Digester Accessories
SUBMITTAL TITLE: 10 Inch Combination Conservation Vent & Flame Arrester - O&M
FILE NAME: 133-R1\_11381-06\_10 Inch Combination Arrester-OM

SUB #: 133
REV #: 1
CODE: 11381-06
DATE: 12/21/2017

WWC REVIEW/COMMENTS: [X] NO EXCEPTIONS [ ] EXCEPTIONS / DEVIATIONS AS NOTED

Previous O&M was preliminary. This resubmittal contains the final test reports.

REVIEWED BY: ST

SIGNED: [Signature]

WWC HAS REVIEWED THIS SUBMITTAL FOR CONFORMANCE WITH THE PROJECT PLANS & SPECIFICATIONS.

OWNER REVIEW:

Table with columns: ITEM, DESCRIPTION, REVIEW STATUS (A, B, C, D, E). Rows include Equipment Summary Form, Data Sheet, Instruction Manual, Test Report, and Drawing.

LEGEND: A = No Exceptions Taken, B = Make Correction Noted, C = Correct & Resubmit, D = Rejected, E = Accepted for Record

OWNER COMMENTS:

REVIEWER'S NAME: \_\_\_\_\_

REVIEWER'S SIGNATURE: \_\_\_\_\_

DATE: \_\_\_\_\_

# Section 2.10 & 2.11

(97570=180718AD1)

## 10" Combination Conservation Vent & Flame Arrester

-Equipment Summary Form

- Data Sheet

-Instruction Manual

-Test Report

- Drawing



BIOGAS  
**SHAND & JURIS**

an **L&J TECHNOLOGIES** company

**EQUIPMENT SUMMARY FORM**

- 1. EQUIPMENT ITEM 10" Combination Conservation Vent & Flame Arrester
- 2. MANUFACTURER L&J Technologies
- 3. EQUIPMENT IDENTIFICATION NUMBER(S) 97570=180718AD1  
(maps equipment number)
- 4. LOCATION OF EQUIPMENT \_\_\_\_\_
- 5. WEIGHT OF INDIVIDUAL COMPONENTS (OVER 100 POUNDS) 350 lbs. total

- 6. NAMEPLATE DATA - Horsepower \_\_\_\_\_  
Amperage \_\_\_\_\_  
Voltage \_\_\_\_\_  
Service Factor (S.F.) \_\_\_\_\_  
Speed \_\_\_\_\_  
ENC Type \_\_\_\_\_  
Capacity \_\_\_\_\_  
Other \_\_\_\_\_

- 7. MANUFACTURER'S LOCAL REPRESENTATIVE  
Name Misco Water  
Address 27101 Burbank, Suite B, Foothill Ranch, CA, 92610  
Telephone Number 949-458-5555

- 8. MAINTENANCE REQUIREMENTS Visual inspection annually, replace soft goods every 5 years, clean as needed.

- 9. LUBRICANT LIST n/a

- 10. SPARE PARTS (recommendations) Vacuum back-up disc (N-8090) (9411-10730)  
Vacuum spacer disc (N-8090) (851445-10721), Vacuum diaphragm (FEP) (851786-011)

- 11. COMMENTS \*Spare parts continuation\* Pressure XOS back-up disc (N-8090)( 9402-17340)

Pressure XOS DIAPHRAGM (FEP)(9402-17271), Vacuum cover O-ring (SP518-RE), Tube bank assembly (9430-10155)  
Pressure XOS spacer disc (9402-24780)

# 97570

## Combination Conservation Vent & Flame Arrester

# SHAND & JUR'S

## 97570 Combination Conservation Vent & Flame Arrester

The Shand and Jurs Model 97570 is a combination of our 94020 Conservation Vent and 94306 Flame Arrester in a single, easy to configure package providing for pressure and vacuum relief, as well as positive flame stop on low pressure tanks containing flammable liquids or solvents having a low flash point.

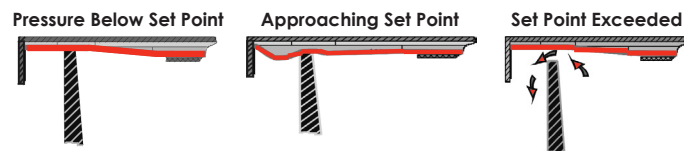
Continued design improvements provide the 94020 conservation vent with high efficiency, maximum flow capacity and minimum leakage. Standard materials of construction are low copper aluminum, cast iron, ductile iron, cast steel and 316 stainless steel for body materials. The conservation vent features cushion seated diaphragms constructed of FEP Teflon for reliability, and extended service life. For high reliability, the pressure and vacuum pallets are both peripherally and center stem guided. Conservation Vents are available in a full range of sizes and configurations, such as open or closed vent (pipe-away). Standard pressure and vacuum settings are 1/2 oz./sq. in.

The 94306 not only provides exceptional protection against fire from external ignition, but also offers maximum flow capacity. The unitized tube bank provides maximum flow while minimizing pressure drop. Standard construction includes light weight cast aluminum, cast iron, cast steel, 304 stainless steel and 316 stainless steel body materials suitable for most environments. Tube bank is available in aluminum, 304 stainless steel and 316 stainless steel as standard. For highly corrosive and severe conditions, special materials and coatings are available. A complete range of sizes from 2" through 12" are available with flat face or raised face flanges to match ANSI 150 lb. connections.

### Expanda-Seal

Shand & Jurs "Expanda-Seal" option is available on all pressure pallet assemblies. This feature significantly reduces leakage. The ballooning effect of the Teflon diaphragm effectively seals the valve.

The "Expanda-Seal" feature ensures less than .5 SCFH of air at 95% of the set point.



### Features

- Sizes 2" thru 12" ANSI and DIN
- Cost effective, dual purpose
- Provides pressure & vacuum relief
- Serves as a barrier between external flame and internal vapors
- Provides protection against flame propagation
- Optional "all weather" coating and insulation jackets available
- Open or closed vent configurations

# SHAND & JUR'S

5911 Butterfield Road Hillside, IL 60162 • tel: (708) 236-6000 • fax: (708) 236-6006  
sales@ljtechnologies.com • www.ljtechnologies.com • ISO 9001:2008 Certified

Rev: 97570-3B

### 94020 Specifications

**Sizes:**

~~2", 3", 4", 6", 8", 10" & 12"~~

**Settings\*:**

Standard Pressure & Vacuum: 1/2 oz./in.<sup>2</sup> (.865 in. W.C.)

**Expanda-Seal Pressure Setting:**

1.5 oz./in.<sup>2</sup> Minimum (Consult Factory for lower settings)

**Maximum Setting W/O Modification:**

	(Pressure)	(Vacuum)**
<del>2":</del>	<del>18 oz./in.<sup>2</sup></del>	<del>8 oz./in.<sup>2</sup></del>
<del>3":</del>	<del>18 oz./in.<sup>2</sup></del>	<del>9 oz./in.<sup>2</sup></del>
<del>4":</del>	<del>18 oz./in.<sup>2</sup></del>	<del>11 oz./in.<sup>2</sup></del>
<del>6":</del>	<del>12 oz./in.<sup>2</sup></del>	<del>12 oz./in.<sup>2</sup></del>
<del>8":</del>	<del>10 oz./in.<sup>2</sup></del>	<del>14 oz./in.<sup>2</sup></del>
<del>10":</del>	<del>8 oz./in.<sup>2</sup></del>	<del>17 oz./in.<sup>2</sup></del>
<del>12":</del>	<del>6 oz./in.<sup>2</sup></del>	<del>21 oz./in.<sup>2</sup></del>

**Service and Body Material:**

Normal: Cast Low Copper Aluminum

~~Low Temperature: Cast Low Copper Aluminum~~

~~Severe: Cast Iron, Ductile Iron, Cast Steel, Cast 316 SS~~

Integral Seats: AL, ~~316 SS, CS with 316 SS seat overlay~~

**Temperature Range:**

Body and Seal -40°F to 220°F.

**Replaceable Seats:**

~~Ryton for: 2" size~~

~~Phenolic for: 3" Thru 12" sizes~~

~~Aluminum for: 2", 3", 4", 6", 8", 10" & 12" sizes~~

~~316 Stainless Steel for: 2", 3", 4", 6", 8", 10" & 12" sizes~~

~~Teflon for: 2", 3", 4", 6", 8" sizes~~

~~SS Teflon Coated for: 2", 3", 4", 6", 8", 10" & 12" sizes~~

**Type of Flange Connection:**

~~Screwed or flanged for: 2" & 3" sizes~~

Flanged for: 4", 6", 8", 10" & 12" sizes

Raised face flange available, except for aluminum body material.

**Options Available:**

Flame Snuffer for all sizes (open vent) and material, except low temperature service. Closed vent for all sizes and materials. Material substitutions as required. Cleaning for LOX/LIN service.

### 94020 Standard Materials of Construction

Component	Normal Aluminum	Low Temperature	Severe		
Body	Cast Aluminum	Cast Aluminum	Cast Iron/Ductile Iron	Cast Steel	316 Stainless Steel
Cover	Aluminum	Aluminum	Steel	Steel	316 Stainless Steel
Hood	18-8 Stainless Steel, PA <sup>1</sup>	Aluminum <sup>2</sup>	18-8 Stainless Steel, PA <sup>1</sup>	18-8 Stainless Steel, PA <sup>1</sup>	316 Stainless Steel
Seats <sup>3</sup>	Aluminum	Aluminum	316 Stainless Steel	316 Stainless Steel	316 Stainless Steel
Stem Guide	Galvanized Iron	316 Stainless Steel	Galvanized Iron	Galvanized Iron	316 Stainless Steel
Pallets	Aluminum	Aluminum	316 Stainless Steel	316 Stainless Steel	316 Stainless Steel
Pressure Stem	316 Stainless Steel	316 Stainless Steel	316 Stainless Steel	316 Stainless Steel	316 Stainless Steel
Vacuum Stem	Aluminum <sup>4</sup>	Aluminum <sup>4</sup>	316 Stainless Steel	316 Stainless Steel	316 Stainless Steel
Screens	Galvanized Steel	304 Stainless Steel	304 Stainless Steel	304 Stainless Steel	316 Stainless Steel
Retainer	Aluminum	Aluminum	316 Stainless Steel	316 Stainless Steel	316 Stainless Steel
Hardware	Zinc Plated Steel	316 Stainless Steel	316 Stainless Steel	Zinc Plated Steel	316 Stainless Steel
Diaphragms	FEP Teflon	FEP Teflon	FEP Teflon	FEP Teflon	FEP Teflon

**NOTES:** 1. 18-8SS for 2", 3", 4", 6" & 8" sizes; spun alum. for 10" & 12" sizes.  
2. 2", 3", 4", 6", 8", 10" & 12" sizes; alum. enclosure w/flapper.

3. Material same as body except CI and DI.  
4. 316SS for elevated settings.

### 94306 Flame Arrester Specifications:

**\*Sizes:**

~~2", 3", 4", 6", 8", 10" and 12"~~ \*Consult Factory for larger sizes

**Max. Static Pressure:**

5 PSI Standard. For higher pressures, Consult Factory.

**Flange Rating:**

To match drilling of ANSI 125/150 lb. flat face or ~~150 lb. raised face~~ (Cast Aluminum body option available with flat face only).

### 94306 Materials of Construction

**Body:**

~~Cast Iron, Cast Steel, Cast Aluminum, 304 Stainless Steel or 316 Stainless Steel~~

**Hardware:**

~~18-8 Stainless Steel Standard, 316 Stainless Steel~~

**Tube Bank:**

~~Aluminum with Aluminum Shell;~~

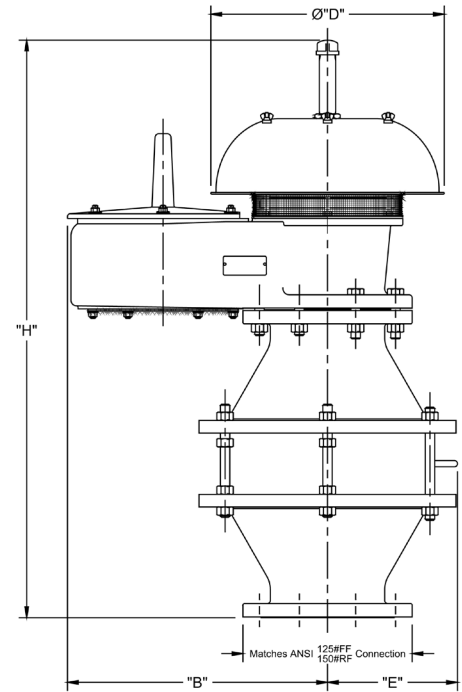
~~304 Stainless Steel with Steel Shell;~~

~~304 Stainless Steel with 304 Stainless Steel Shell;~~

~~316 Stainless Steel with 316 Stainless Steel Shell~~

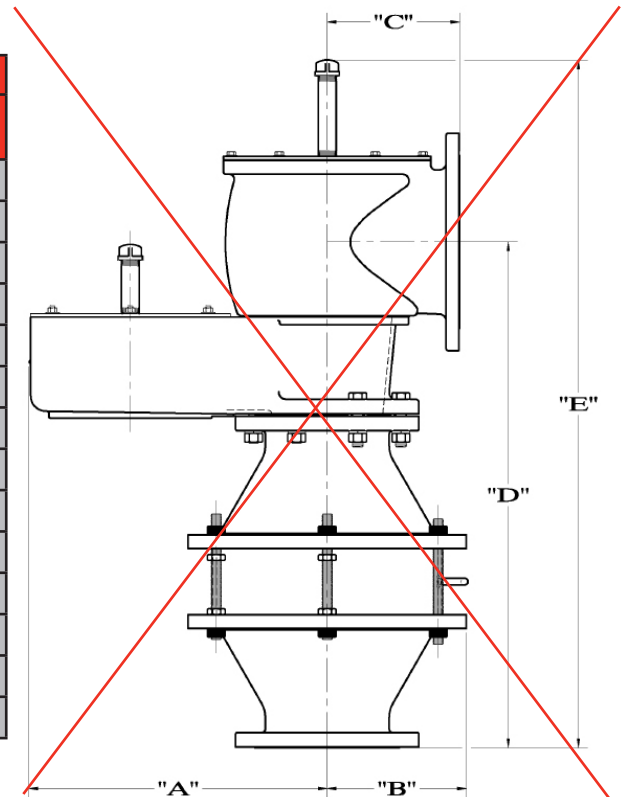
Open Vent Outline Dimensions

Dimensions (Inches [mm])				
Valve Size	"B"	Diameter "D"	"E"	"H"
2 [50]	8 13/16 [224]	12 7/8 [327]	7 5/8 [194]	26 9/16 [675]
3 [75]	11 3/16 [284]	13 9/16 [345]	8 5/16 [211]	29 7/16 [748]
4 [100]	13 9/16 [345]	15 19/16 [405]	6 13/16 [173]	33 11/16 [856]
6 [150]	16 11/16 [424]	18 5/8 [473]	8 1/4 [210]	38 11/16 [983]
8 [200]	20 1/2 [521]	18 5/8 [473]	10 1/4 [260]	45 13/16 [1164]
10 [250]	24 11/16 [627]	25 9/16 [649]	12 1/4 [311]	57 1/16 [1449]
12 [300]	29 1/16 [738]	29 7/8 [759]	14 3/8 [365]	65 3/16 [1656]



Closed Vent Outline Dimensions

Dimensions (Inches [mm])					
Valve Size Inlet x Outlet	"A"	"B"	"C"	"D"	"E"
2" x 2"	8 29/32 [226]	4 1/4 [108]	4 1/4 [108]	18 19/32 [468]	24 9/16 [624]
2" x 3"	[226]	[108]	4 1/4 [108]	18 7/16 [468]	24 9/16 [624]
3" x 3"	11 1/8 [283]	5 1/4 [133]	5 1/4 [133]	21 9/32 [540]	29 7/16 [748]
3" x 4"	[283]	[133]	5 1/4 [133]	21 5/8 [549]	29 7/16 [748]
4" x 4"	12 15/16 [328]	6 3/16 [157]	6 1/2 [165]	24 3/32 [633]	38 5/16 [973]
4" x 6"	[328]	[157]	5 15/16 [151]	24 15/16 [633]	34 1/4 [870]
6" x 6"	17 13/16 [452]	8 3/16 [208]	8 3/8 [213]	29 9/32 [743]	41 3/16 [1046]
6" x 8"	[452]	[208]	8 1/4 [210]	30 7/32 [767]	41 1/4 [1048]
8" x 8"	21 31/32 [558]	10 1/4 [260]	9 3/4 [248]	36 9/32 [920]	50 3/4 [1289]
8" x 10"	[558]	[260]	9 3/4 [248]	37 1/4 [946]	50 3/4 [1289]
10" x 10"	26 3/8 [670]	12 1/4 [311]	11 19/32 [294]	42 27/32 [1087]	59 3/16 [1503]
10" x 12"	[670]	[311]	11 19/32 [294]	43 23/32 [1110]	59 3/16 [1503]
12" x 12"	30 11/16 [780]	14 3/8 [365]	12 13/16 [325]	49 7/32 [1249]	67 [1702]
12" x 14"	[780]	[365]	12 13/16 [325]	49 3/4 [1264]	66 3/4 [1696]



All designs subject to change. Certified dimensions and specifications available upon request.

## 97570 Ordering Guide

### Model Number Selection

The model number will have a base number **97570** followed by 9 digit numbers. These digits will represent 8 sets of option tables.

**97570 - AB - CD - EF - GH - I**

**Table AB - Size and Body Material**

Option AB	Size	Type of Connection	Body Material
11	2"	NPT	Aluminum
12	2"	Flanged	Aluminum
21	2"	NPT	Alum Cryo Hood
22	2"	Flanged	Alum Cryo Hood
*31/41	2"	NPT	Cast Iron/Ductile Iron
*32/42	2"	Flanged	Cast Iron/Ductile Iron
51	2"	NPT	Cast Steel
52	2"	Flanged	Cast Steel
71	2"	NPT	316 Stainless Steel
72	2"	Flanged	316 Stainless Steel
13	3"	NPT	Aluminum
14	3"	Flanged	Aluminum
23	3"	NPT	Alum Cryo Hood
24	3"	Flanged	Alum Cryo Hood
*33/43	3"	NPT	Cast Iron/Ductile Iron
*34/44	3"	Flanged	Cast Iron/Ductile Iron
53	3"	NPT	Cast Steel
54	3"	Flanged	Cast Steel
73	3"	NPT	316 Stainless Steel
74	3"	Flanged	316 Stainless Steel
15	4"	Flanged	Aluminum
25	4"	Flanged	Alum Cryo Hood

\* 3X = Cast Iron      4X = Ductile Iron

Option AB	Size	Type of Connection	Body Material
*35/45	4"	Flanged	Cast Iron/Ductile Iron
55	4"	Flanged	Cast Steel
75	4"	Flanged	316 Stainless Steel
16	6"	Flanged	Aluminum
26	6"	Flanged	Alum Cryo Hood
*36/46	6"	Flanged	Cast Iron/Ductile Iron
56	6"	Flanged	Cast Steel
76	6"	Flanged	316 Stainless Steel
17	8"	Flanged	Aluminum
27	8"	Flanged	Alum Cryo Hood
*37/47	8"	Flanged	Cast Iron/Ductile Iron
57	8"	Flanged	Cast Steel
77	8"	Flanged	316 Stainless Steel
18	10"	Flanged	Aluminum
28	10"	Flanged	Alum Cryo Hood
*38/48	10"	Flanged	Cast Iron/Ductile Iron
58	10"	Flanged	Cast Steel
78	10"	Flanged	316 Stainless Steel
19	12"	Flanged	Aluminum
29	12"	Flanged	Alum Cryo Hood
*39/49	12"	Flanged	Cast Iron/Ductile Iron
59	12"	Flanged	Cast Steel
79	12"	Flanged	316 Stainless Steel

**Table C - Flange Type**

Option C	Description
0	FF ANSI 150 lb
1	*RF ANSI 150 lb
2	DIN PN 16 FF
3	DIN PN 16 RF*
4	JIS 10K FF
5	JIS 10K RF*

\* RF not available in Aluminum

**Table D - Vent Type**

Option D	Description
1	Open Vent
2	Open Vent w/ Flame Snuffer
3	Closed, Standard Outlet > Inlet*
4	Pipe Away, P&V
6	Pipe Away, Same Size Inlet, Outlet, Seat
7	Open Vent with "All Weather" Coating
8	Open Vent with Flame Snuffer with "All Weather" Coating
9	Closed, Standard Outlet > Inlet with "All Weather" Coating
A	Pipe Away, Same Size Inlet, Outlet, Seat with "All Weather Coating
B	Open Vent with "All Weather" Coating with Insulation Jacket
C	Open Vent with Flame Snuffer with "All Weather" Coating & Insulation Jacket
D	Closed, Standard Outlet > Inlet with "All Weather" Coating & Insulation Jacket
E	Pipe Away, Same Size Inlet, Outlet, Seat with "All Weather Coating & Insulation Jacket

\* Standard closed vent (outlet is one size larger than the inlet).  
Ex. 2" Inlet X 3" Outlet, 6" Inlet X 8" Outlet.

**NOTE:** Option 6 replaced Option 5. Dimensions are not identical. Consult Factory if replacement valve is required.

**Table E - Seal Type and Softgoods**

Option E	Description
0	Normal FEP / N8090
1	Expand-Seal FEP / N8090
2	Normal FEP (All)
3	Expand-Seal FEP (All)
4	Normal Viton
5	Expand-Seal Viton
6	Normal PTFE
8	Normal Buna
9	Expand-Seal Buna

**Table F - Pressure Range & Load Weight Material**

Option F	Description	Material
1	**Standard Pressure and Vacuum Setting = 0.5 oz/in <sup>2</sup>	Lead
2	Over 2.9 oz/sq. in. to Maximum Setting	Lead
3	> Standard to 2.9 oz/in <sup>2</sup>	Lead
4	**Standard Setting	316 SS
5	Over 2.9 oz/in. <sup>2</sup> to Maximum Setting	316 SS
6	> Standard to 2.9 oz/in. <sup>2</sup>	316 SS
7	Incremental Weights Pressure Only 2.9 Oz. - 14 Oz. (5 in. W.C. - 24 in. W.C.)	Lead
8	Standard Incremental Weight Set Pressure Only 6" -16" W.C. in 1" Increments Including (1)-1/2 In. and (2)-1/4 In. W.C. Weights	Lead

\*\*Expand-Seal min. pressure setting: 1.5 oz/in.<sup>2</sup>

**Table G - Seat & Pallet Material**

Option G	Seat	Pallet
A	Standard*	Standard*
B	Teflon	Standard*
C	Aluminum	Standard*
D	Phenolic	Standard*
E	Stainless Steel	Standard*
F	Teflon Coated SS	Standard*
G	Standard*	316 Stainless Steel
H	Teflon	316 Stainless Steel
I	Aluminum	316 Stainless Steel
J	Phenolic	316 Stainless Steel
K	Stainless Steel	316 Stainless Steel
L	Teflon Coated SS	316 Stainless Steel

\*See Materials of Construction

Options G-L are applicable for Aluminum bodies only. 316 SS Pallet is standard on all other body options.

**Table H - Cleaning & Trim**

Option H	Cleaning	Trim
A	Normal	Standard
B	LOX	Standard
C	LIN	Standard
D	Normal	316 Stainless Steel
E	LOX	316 Stainless Steel
F	LIN	316 Stainless Steel

LOX = Liquid Oxygen

LIN = Liquid Nitrogen

Trim Includes Stem, Stem Guides, Side Guides, Nuts, Bolts and Screen.

**NOTE:** LOX/LIN cleaning for Cryogenic Breathers of aluminum construction includes degreasing before assembly only!

**Table I - Flame Arrester Housing, Bank Assembly Frame & Sheet Metal\***

Option I	Tube Bank Material	Shell Material
1	Aluminum	Aluminum
6	304 Stainless Steel	Cast Steel
2	316 Stainless Steel	316 Stainless Steel
4	304 Stainless Steel	304 Stainless Steel

\* Tie Rods and Nuts available in 18-8 SS Standard. If 316 SS required, please refer to Option H.

**SAFETY INFORMATION**

Before proceeding, any addendum along with the instruction manual must be fully read and understood. Periodically throughout this manual, the words Danger, Warning, Caution and Note may occur. These are reminders to be especially careful. See the descriptions below for more details on what each word denotes.

**! DANGER**

Indicates an imminently hazardous situation which, if not avoided, "will" result in death or serious injury. This word is limited to the most extreme situations.

**! WARNING**

Indicates a potentially hazardous situation which, if not avoided, "could" result in death or serious injury.

**! CAUTION**

Indicates a potentially hazardous situation which, if not avoided, "may" result in minor or moderate injury, or damage to the instrument being worked on.



**Note:** Is meant to add some measure of help or give useful information to the person working on the instrument.

**! WARNING**

It is important to take the following precautions before you start work on the vent.

1. Personnel installing or performing maintenance to the vent must be competent and utilize approved equipment and clothing normally used to work with the process media where the vent is installed.
2. The tank the vent is installed must be at atmospheric pressure conditions and free of hazardous vapors.
3. Handling of the vent must be done by personnel trained in all aspects of manual and mechanical handling techniques.
4. Vent must be properly sized for tank conditions. Incorrect sizing can result in tank and or vent destruction.

**RECEIVING**

This shipment, it sold F.O.B. HILLSIDE, ILLINOIS is the property of the purchaser when it leaves our plant. Claims for damage must be taken up with the transportation company promptly if this shipment is received in damaged condition. Notify the agent of the transportation company at once and preserve box, packing and contents as received.

The Shand & Jurs method of packing these goods has been proven by many years of experience and the transportation company has contracted to deliver this material to you in as good condition as they received it from us.

The breather valve and flame arrester should remain in its shipping carton until ready to mount on the tank nozzle. The shipping container contains the breather valve and flame arrester, the pallet loading weights (if required) and mounting hardware. Mounting bolts and the flange gasket for the tank are not furnished with the valve.

**DESCRIPTION**

The model 97570 consists of model 94020 pressure and vacuum relief vent mounted on top of the model 94306 end of line flame arrester.

**INSTALLATION**

The relief vent and flame arrester are shipped separately to prevent damage. The hardware and gasket for mounting the relief vent to the flame arrester is included. Refer to manuals 94-020I-1 and 94-306 for detailed instructions and all safety warnings.

**SHAND&JURS**  
an **L&J TECHNOLOGIES** Company

5911 Butterfield Road • Hillside, Illinois 60162  
Phone: (708) 236-6000 • Fax: (708) 236-6006  
[www.ljtechnologies.com](http://www.ljtechnologies.com)

**ISO** 9001  
REGISTERED

All designs subject to change. Certified dimensions and specifications available upon request.

**SAFETY INFORMATION**

Before proceeding, any addendum along with the instruction manual must be fully read and understood. Periodically throughout this manual, the words Danger, Warning, Caution and Note may occur. These are reminders to be especially careful. See the descriptions below for more details on what each word denotes.

**⚠ DANGER**

Indicates an imminently hazardous situation which, if not avoided, "will" result in death or serious injury. This word is limited to the most extreme situations.

**⚠ WARNING**

Indicates a potentially hazardous situation which, if not avoided, "could" result in death or serious injury.

**⚠ CAUTION**

Indicates a potentially hazardous situation which, if not avoided, "may" result in minor or moderate injury, or damage to the instrument being worked on.



**Note:** Is meant to add some measure of help or give useful information to the person working on the instrument.

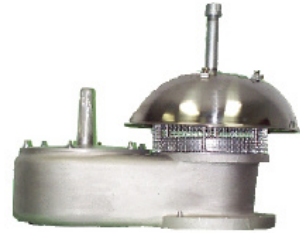
**⚠ WARNING**

It is important to take the following precautions before you start work on the vent.

1. Personnel installing or performing maintenance to the vent must be competent and utilize approved equipment and clothing normally used to work with the process media where the vent is installed.
2. The tank the vent is installed must be at atmospheric pressure conditions and free of hazardous vapors.
3. Handling of the vent must be done by personnel trained in all aspects of manual and mechanical handling techniques.
4. Vent must be properly sized for tank conditions. Incorrect sizing can result in tank and or vent destruction.

**IMPORTANT**

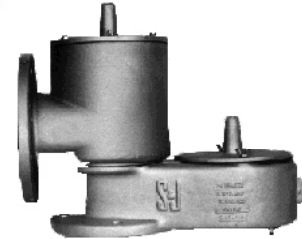
Replacement hoods for the 2", 3", and 4" sizes originally supplied with cast iron hoods require a parts kit and replacement procedure. Replacement hoods for the 8", 10" and 12" sizes originally supplied with two wing nuts for retainment also require a kit and replacement procedure, consult factory.

**Open Vent Model**

Available in  
2",3",4",6",8",  
10"&12" sizes

**Closed Vent Model**

Available in  
2",3",4",6",8",  
10"&12" sizes



**Figure 1.**  
**RECEIVING**

This shipment, it sold F.O.B. HILLSIDE, ILLINOIS is the property of the purchaser when it leaves our plant. Claims for damage must be taken up with the transportation company promptly if this shipment is received in damaged condition. Notify the agent of the transportation company at once and preserve box, packing and contents as received.

The Shand & Jurs method of packing these goods has been proven by many years of experience and the transportation company has contracted to deliver this material to you in as good condition as they received it from us.

The breather valve should remain in its shipping carton until ready to mount on the tank nozzle. If inspection is necessary on receiving, unpack as directed in Part III, then repack carefully in the same manner as originally received. The shipping container contains the breather valve, the pallet loading weights (if required) and mounting stud nuts. Mounting bolts and the flange gasket are not furnished with the valve.



**NOTE:** Loading weight (over 5 lbs.) is shipped loose in the same carton and must be unpacked and kept with the respected breather.

**MOUNTING**

A. Remove loading weights from carton and set aside. Remove the breather valve from the carton at the tank nozzle. Do not handle the six inch and larger sizes by the spun metal hood. Use nonmetallic rope or slings in handling.

B. Pipe dope or compound used in mounting screwed connection 2" NPT and 3" NPT breather vents should not enter the vent where it may interfere with efficient venting.

Flange mounted valves fit ASA 125 lb. flat face flanges or ANSI 150# RF flanges depending on which options were selected. Place gasket on tank nozzle flange. Mount valve using care not to damage the gasket and outer rim of the vacuum seat and screen. Tighten bolts and nuts to evenly compress the flange gasket. Mounting holes in the 4" and larger sizes straddle the centerline. 2" & 3" mounting holes are on the centerline. See Step E for models with flame snuffer.

C. Pallets must be horizontal after mounting.

D. Additional for Closed Venting Models:

Size of flanges on outlet for closed venting models is next full size larger than breather valve size, i.e., 3" flange used on 2" valve, 4" flange used on 3" valve, 8" flange used on 6" valve.

Place gasket on outlet flange then draw up closed vent piping snug and flush with vent flange. Tighten fasteners to evenly compress gasket.

**NOTE: If piping is not properly supported leakage can develop between the two bodies. Closed vent piping MUST not place any stress or strain on the breather vent.**

### Bolting Torque (Mounting) Recommendations

Size	Bolt Mounting Torque
2"	200 in. lbs. (17 ft. lbs.)
3"	300 in. lbs. (25 ft. lbs.)
4"	375 in. lbs. (31 ft. lbs.)
6"	396 in. lbs. (33 ft. lbs.)
8"	612 in. lbs. (51 ft. lbs.)
10"	882 in. lbs. (74 ft. lbs.)
12"	882 in. lbs. (74 ft. lbs.)

E. Additional for Models with Flame Snuffer:

Mount to orient the operating handle towards the tank edge as shown on the drawing. Insert a mounting bolt through the hole in the cable guide bracket before using it to fasten the valve to the tank nozzle. The bracket is to hang the cable over the tank edge without touching the side of the tank. If cable pulls down on the operating lever, loosen screws on the cable clamp under the guide bracket to relieve the tension and then slide the clamp to the bracket before retightening the screws.

### PROTECTIVE PACKING REMOVAL

A1. 2", 3", and 4" valve.

Remove the vacuum cover and pressure vent hood by removing wing nuts.

A2. 6", 8", 10", and 12" valve.

Remove the pressure vent hood by removing wing nuts and raise it from the valve. Remove the vacuum vent cover by removing the nuts and the cover.

B. Remove the pressure pallet on the 2", 3", and 4" valve by lifting it straight out. On the other models the support ring must be removed.

C. Remove the vacuum pallet by grabbing the stem, slightly lift and then tilt toward the back of the valve and guiding the pallet through the hole.

D. Wipe off any foreign material from all internal surfaces. Examine the pallets, diaphragms and seats paying particular attention to the seating surfaces for chips and nicks, and to the diaphragm for damage that might cause the valve to leak. Carefully place the pallets on their seats.

E. Add loading weights, if supplied for elevated setting. When a distribution plate (steel) is supplied with the loading weights, then place the plate on first followed by the lead loading weights. Be sure weights are identified for pressure and vacuum are on the proper pallets.

F. Replace the valve covers and hoods.

1. Carefully align the stem into the cover guide while placing the vacuum cover or pressure hoods into position.

**NOTE: On 6", 8", 10", and 12" open vent the support ring must be in place before the hood can be placed into position.**

2. After the hoods and/or covers are in place, fasten them down with wing nuts.

**CAUTION**

When installing and servicing pallets, be sure the pallet stem extends 1/4" minimum into the center guide (when pallet is resting on the seat) and pallet lift is not obstructed. Install only the weights supplied for the pallet (pressure or vacuum), Otherwise full rated flow capacity of set point may not be achieved, resulting in excess pressure or vacuum and possible tank damage.

### SERVICE

A. VACUUM COVER GASKET REPLACEMENT.

1. Clean gasket surface and replace o-ring gasket.

B. SEAT REPLACEMENT (If removable)

1. If seat replacement is required, use care when cleaning the seat mounting area. Apply Permatex #2 (SP390-A) or teflon sealant (whatever the original sealant was) to the body seating surface. Set seat in place and fasten to the body. For lox (oxygen service)

gasket is lightly coated with halocarbon grease.

2. Vacuum seat is mounted from the under side. The vacuum screen is also held by the same hardware as the seat.

3. Once the seats are fastened in place, the top surface is checked for flatness. In most cases a light sanding or lapping of the top surface is required. Using a flat metal plate, one side grounded, then affix a fine grit emery cloth (#120) and polish the seat, until flat.

**NOTE:** The disc should be the same diameter as the pallet O.D. with a center rod and a ‘T’ handle at the top.

**C. DIAPHRAGM REPLACEMENT**

1. Disassemble the nut from the stem and remove the retainer, diaphragm, back-up disc, and spacer washer.

2. Apply Permatex #2 to the stem just above the threads to seal the stem and the pallet. Lox service use Teflon tape.

3. Replace whichever components are worn or damaged and reassemble.

4. Be sure the replacement diaphragm lies smooth, without creases or wrinkles before tightening the fastener.

**D. HOOD REPLACEMENT**

1. The hood is held on by wing nuts. Some sizes use beveled washers under the wing nuts.

2. The 6”, 8”, 10”, and 12” sizes require a support ring to stiffen the hood, which helps to prevent wind damage.

3. Replacement hoods for models made prior to July 1970 consult factory for additional hardware required.

**OPERATION**

Model 94020 Breather Valve is fully automatic. No lubrication is required.

**INSPECTION AND MAINTENANCE**

Recommended minimum once every three months.

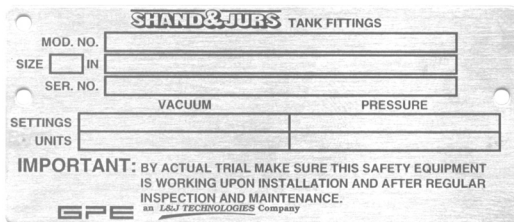
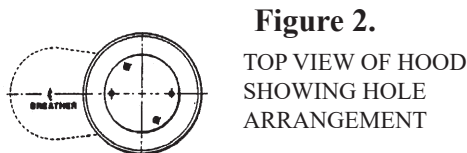
A. Refer to previous sections for cover, hood and pallet removal and reinstallation.

B. Before removing the pallets, brush all accumulations from the protecting screens, the pallets, and all surfaces of the valve. Brush the screens from inside the valve so that dirt, etc, falls to the outer sides. Remove heavy loading weights prior to removing pallet assembly.

C. Inspect gaskets, seats, diaphragm, pallets stems and stem guides. Remove any gummy deposits or foreign matter using reasonable care not to damage diaphragms or seats. Check all mating surfaces which must be free of nicks, cuts, cracks or deposits that might interfere with proper seating or tightness of the valve.

D. Make certain that the pallets move freely up and down over their full range of travel. Replace loading weights after check.

**NOTE:** Air groove pallet standard on all versions except PTFE and higher set points. Elevated pressure settings require the use of classic style “air cushioned” pallets and reinforced vacuum pallets. Refer to the appropriate figures for maintenance. Consult Factory for your configuration.



**Standard Materials of Construction**

Service	Body	Vacuum Cover	Open Vent Hood		Seat		Pallets	Stem Guide Tube	Screen
			2,3,4, 6&8	10 & 12	2,3,4	6,8 10 & 12			
Norm. Alum.	Cast Alum.	Cast Alum.	18-8	Alum.	Alum.	Alum.	Alum.	Galv. Iron	Galv. Steel
Cyro Low. Temp	Cast Alum.	Cast Alum.	Alum.	Alum.	Alum.	Alum.	Alum.	316ss	304ss
Severe Iron	Cast Iron	Cast Iron	18-8	Alum.	316ss	316ss	316ss	Galv. Iron	304ss
Severe Steel	Cast Steel	Cast Steel	18-8	Alum.	316ss	316ss	316ss	Galv. Iron	304ss
Severe 316ss	Cast 316ss	Cast 316ss	316ss	316ss	316ss	316ss	316ss	316ss	316ss

Service	Pallet Stem		Diaph.	Closed Vent Body/Cover		Cover Gaskets	Hardware
	Pressure	Vacuum		2,3,4	6,8,10,12		
Norm. Alum.	316ss	Alum.*	FEP	Alum.	Alum.	N-8090	St. Zinc Plated
Cyro Low. Temp	316ss	Alum.*	FEP	Alum.	Alum.	N-8090	316ss
Severe Iron	316ss	316ss	FEP	C.I.	Steel	N-8090	316ss
Severe Steel	316ss	316ss	FEP	Steel	Steel	N-8090	St. Zinc Plated
Severe 316ss	316ss	316ss	FEP	316ss	316ss	N-8090	316ss

\* 316ss for Elevated Settings  
 N-8090 = Nitrile Fiber Composition Non-asbestos  
 FEP = Teflon

## SPECIAL OPTIONS

### Visual Memory Indicator- pressure only

A Visual Memory Indicator is available to provide an indication of pallet pressure lift. Once the memory stem moves up, it will remain in that position until reset manually. To reset remove the top cap and push down on the memory stem so that the bottom of the stem touches the bottom of the pallet stem. The visual memory indicator installs on the open vent hood or closed vent cover. A special Pallet stem is also required.

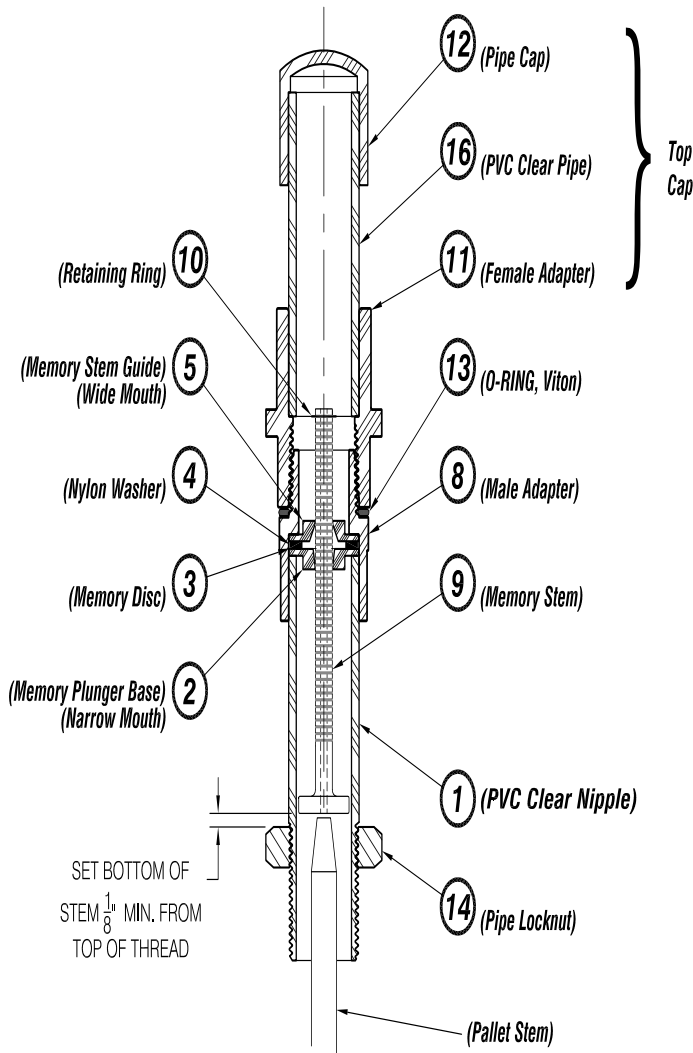


Figure 3.

### Pressure/Vacuum Pallet Switches

Proximity switches are available to detect when the pressure or vacuum pallet has lifted off of its seat approximately 1/8th inch (.125") which provides indication of flow (not leakage). The switches are activated by vertical movement of the metal pallet stem. Dry contact outputs are provided.

## INSTALLATION

Switch and enclosure are explosion proof and rated for Class I Div 1 Groups C&D hazardous locations. All wiring must be in accordance with all applicable regulatory local and national codes.



**NOTE: Connecting wiring must be supported in a manner as not to put stress on the connection boxes. Flexible conduit is highly recommended in order to make it easy to handle the hood or closed vent cover when removal is required for inspection of pressure pallet.**

These units are precalibrated. See Section "Switch Settings" if recalibration is required.

#### Vacuum Pallet Switch:

Vacuum Switch Assembly is shipped unassembled from the valve to protect it from damage during shipping. To reassemble - match the tag number with the same number on the cover. Remove the loose nut and push the switch through the vacuum bracket hole, threading the loose nut on until it stops. Orientate the switch in the desired direction and carefully wrench tighten the nut. Do not overtighten.

#### Hood Replacement (with switch):

1. Hoods with switch mountings require a support plate to stiffen the hood, which helps to prevent wind damage, and premature switch contact transfer.
2. Hoods with switches should have flexible conduit wiring connection to allow removal of the hood without disconnecting any wires.

### CAUTION

Do not bend activator stem while servicing the unit.

### SWITCH SETTING

#### Pressure Switch Adjustment:

Adjustment of the switch is determined by lowering or raising the stem guide (1" pipe). The stem guide screws into a support plate and is locked in place by a jam nut. See Figure 4A.

Loosen the captive nut (4) (DO NOT REMOVE) and also the large jam nut (3). To lessen the distance of the pallet it has to move before the switch contacts will transfer, turn the stem guide (1) clockwise. To increase the distance, turn the stem guide counterclockwise. **NOTE: A meter must be hooked up to the terminal block inside of junction box to determine contact transfer.**

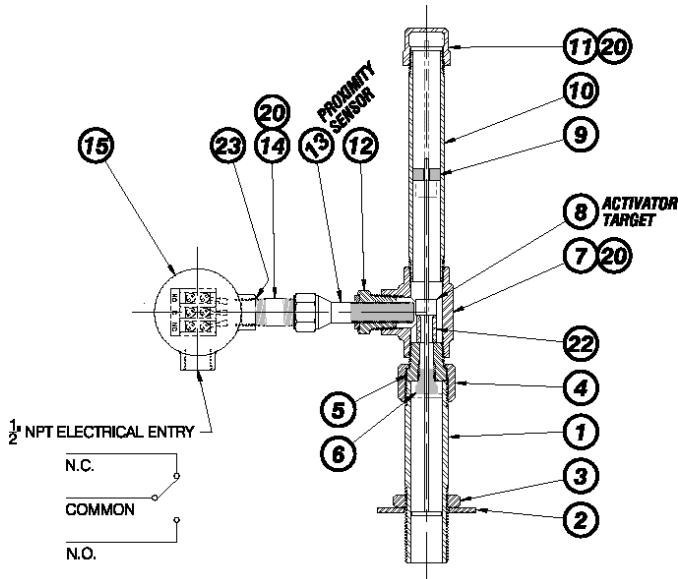
After turning the stem guide in one direction tighten both

captive nut and the locknut. Confirm setting by lifting the pallet manually and watching the meter for contact transfer.

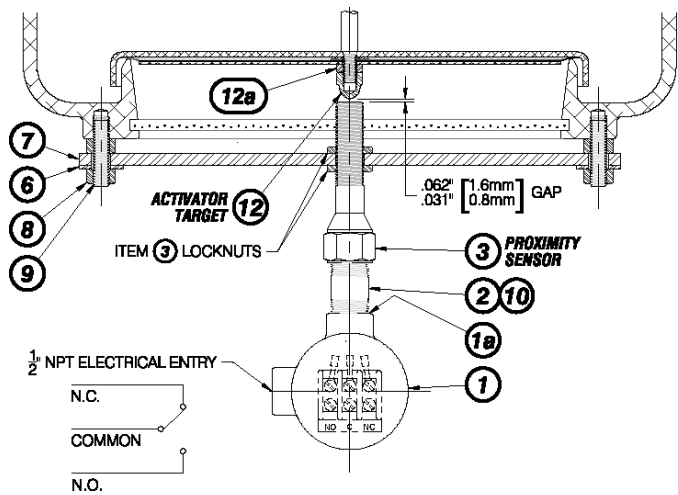
**Vacuum Switch Adjustment:**

Adjustment of this switch is determined by lowering or raising the switch via two locknuts. The two locknuts (3) are located on a Retainer bar (7) under the vacuum pallet. See Figure 4B.

To lessen the distance the pallet has to travel before the switch contacts transfer, loosen and turn the top locknut and tighten the bottom locknut. This increases the distance between the switch and the sensor bolt on the pallet.



**Figure 4A.**



**Figure 4B.**

To increase the distance do the reversal of the latter. However do not adjust the switch whereas it would touch the sensor bolt. Confirm setting by lifting the pallet manually while watching the meter for contact transfer

**SPARE PARTS**

Order parts through the nearest Shand & Jurs office, representative or distributor or direct from our factory.

When ordering replacement parts, be sure to use the complete equipment model number, description of the part being ordered and its related part number. Make sure the model number contains all option numbers as described in the Model Number Identification Paragraph.

**TROUBLESHOOTING**

1. Breather valve leaks or relieves pressure before reaching Set-Point.
  - Check pallet weights. If weight is low, add appropriate weights.
  - Inspect diaphragm and other soft goods on pressure pallet. Replace soft goods if damaged or scratched.
  - Inspect seat. If seat is scratched, it should be repaired.
2. Breather valve does not relieve pressure above Set-Point.
  - Check pallet weights. If weight is too high remove appropriate weights.
  - Check movement of pressure pallet. It should move freely up and down.
  - Inspect pressure pallet stem guide to be sure there is no binding of the pallet stem or the memory stem.
3. Breather valve relieves vacuum before reaching Set-Point.
  - Check pallet weights. If weight is low, add appropriate weights.
  - Inspect diaphragm and other soft goods on vacuum pallet. Replace soft goods if damaged or scratched.
  - Inspect seat. If seat is scratched, it should be repaired or replaced.

# MODEL NUMBER EXPLANATION

If model number contains extra digit "I", Then GHI defines a custom vent per sales order.

94020-AB-CD-EF-GHI

Key No.   
 Valve, Size, Material

Option AB	Size	Type of Connection	Body Material
11	2"	NPT	ALUM
12	2"	Flanged	ALUM
21	2"	NPT	ALUM CRYO HOOD
22	2"	Flanged	ALUM CRYO HOOD
*31/41	2"	NPT	CI/DI
*32/42	2"	Flanged	CI/DI
51	2"	NPT	CS
52	2"	Flanged	CS
71	2"	NPT	316SS
72	2"	Flanged	316SS
13	3"	NPT	ALUM
14	3"	Flanged	ALUM
23	3"	NPT	ALUM CRYO HOOD
24	3"	Flanged	ALUM CRYO HOOD
*33/43	3"	NPT	CI/DI
*34/44	3"	Flanged	CI/DI
53	3"	NPT	CS
54	3"	Flanged	CS
73	3"	NPT	316 SS
74	3"	Flanged	316 SS
15	4"	Flanged	ALUM
25	4"	Flanged	ALUM CRYO HOOD
*35/45	4"	Flanged	CI/DI
55	4"	Flanged	CS
75	4"	Flanged	316 SS
16	6"	Flanged	ALUM
26	6"	Flanged	ALUM CRYO HOOD
*36/46	6"	Flanged	CI/DI
56	6"	Flanged	CS
76	6"	Flanged	316 SS
17	8"	Flanged	ALUM
27	8"	Flanged	ALUM CRYO HOOD
*37/47	8"	Flanged	CI/DI
57	8"	Flanged	CS
77	8"	Flanged	316 SS
18	10"	Flanged	ALUM
28	10"	Flanged	ALUM CRYO HOOD
*38/48	10"	Flanged	CI/DI
58	10"	Flanged	CS
78	10"	Flanged	316 SS
19	12"	Flanged	ALUM
29	12"	Flanged	ALUM CRYO HOOD
*39/49	12"	Flanged	CI/DI
59	12"	Flanged	CS
79	12"	Flanged	316 SS

### Flange Type

- 0 = FF ANSI 150 LB
- 1 =\* RF ANSI 150 LB
- 2 = DIN 2633 PN 16 FF
- 3 = DIN 2633 PN 16 RF
- 4 = JIS 10K FF
- 5 = JIS 10K RF

\* RF not available in Aluminum

### Vent Type

- 1 = Open Vent
  - 2 = Open Vent with Flame Snuffer
  - 3 = Closed, Standard Outlet>Inlet\*
  - 4 = Pipe Away, P&V
  - 6 = Pipe Away, Same Size in, out, Seat
  - 7 = Open Vent with "All Weather" Coating
  - 8 = Open Vent with Flame Snuffer w/ "All Weather" Coating
  - 9 = Closed, Standard Outlet>Inlet w/ "All Weather Coating
  - A = Pipe Away, Same Size in, out, Seat w/ "All Weather" Coating
- \* Standard closed vent (outlet is one size larger than inlet)

### Special Cleaning, Trim

- | <u>Cleaning</u> | <u>Trim</u> |
|-----------------|-------------|
| 0 = Normal      | Standard    |
| 1 = LOX         | Standard    |
| 2 = LIN         | Standard    |
| 5 = Normal      | 316 S.S.    |
| 6 = LOX         | 316 S.S.    |
| 7 = LIN         | 316 S.S.    |
| 8 = Normal      | Monel       |
| 9 = LOX         | Monel       |
| A = LIN         | Monel       |

### Seat & Pallet Material

- | <u>Seat</u>            | <u>Pallet</u> |
|------------------------|---------------|
| 0 = Standard*          | Standard      |
| +1 = Teflon            | Standard      |
| 2 = Al                 | Standard      |
| +3 = Phenolic          | Standard      |
| 4 = S.S.               | Standard      |
| 5 = Teflon Coated S.S. | Standard      |
| A = Standard           | 316 S.S.      |
| +B = Teflon            | 316 S.S.      |
| C = Al                 | 316 S.S.      |
| +D = Phenolic          | 316 S.S.      |
| E = S.S.               | 316 S.S.      |
| F = Teflon Coated S.S. | 316 S.S.      |

\* See materials of construction

+ These options not available for ATEX models.

### Pressure Range & Seal Type

#### Pressure Range

- 1 = Standard Pres & Vac .5oz./sq.in.\*\*
- 2 = Over 2.9 oz./sq.in.
- 3 = Std. to 2.9 oz./sq.in.
- 4 = Standard Setting\*\*
- 5 = Over 2.9 oz./sq.in.
- 6 = Std. to 2.9 oz./sq.in.
- 7 = Incremental Weights Pressure Only  
2.9 oz - 14 oz.
- 8 = Std. Incremental Weight Set Pressure  
Only 6"-16" W.C. in 1" Increments  
Including (1)-1/2 In. and (2)-1/4 In.  
W.C. Weights

\*\* Expanda-Seal Min., Pres 1.5oz./sq.in.

#### Material

- Lead
- Lead
- Lead
- 316 S.S.
- 316 S.S.
- 316 S.S.

### Seal Type & Soft Goods

#### Seal Type

- 0 = Normal
- 1 = Expanda
- 2 = Normal
- 3 = Expanda
- 4 = Normal
- 5 = Expanda
- 6 = Normal
- 8 = Normal
- 9 = Expanda

#### Soft Goods

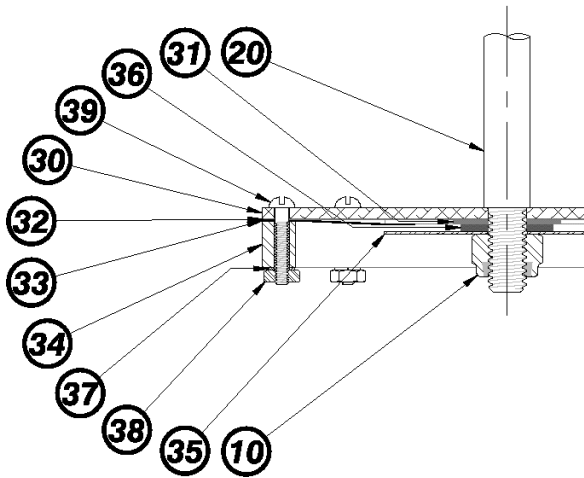
- Teflon Diaphragm, N8090 Back-up  
Disc, Spacer on HI press only
- Teflon Diaphragm, N8090 Back-up  
Disc and Spacer
- ALL TFE
- ALL TFE
- Viton
- Viton
- PTFE
- Buna Diaphragm
- Buna Diaphragm

\*CONSULT FACTORY FOR PART NUMBER IDENTIFICATION AND SPARE PARTS FOR YOUR MODEL.

Item. No	Description	Material	Used in Table 1 Option No.	Part No.		
				2"	3"	4"
1	Diaphragm	.005 Teflon	All (Set Point <5" WC)	851786-001	851786-002	851786-003
		.010 Teflon	All (Set Point <5" WC)	851786-008	851786-009	851786-010
2	Backup Disc	N8090	All (Set Point <5" WC)	851105-001	851105-002	851105-003
3	Spacer	Cork	11, 15	851445-001	851445-002	851445-003
		N8090	21-25, 31-35, 51-55, 71-75	851445-008	851445-009	851445-010
4	Sealant, Seat Gasket, Seat	Permatex #2	11-15, 31-35, 51-55, 71-75	SP390-A	SP390-A	SP390-A
		N8090	21-25	851871-001	852860-001	852862-001
5	VAC Cover O-Ring	Buna "N"	All	SP518-DB	SP518-DP	SP518-DX
		Viton	All	SP354-DB	SP354-DP	SP354-DX
6	CV Cover Gasket	N8090	All	851810-001	851810-002	851810-003
7	Washer	Fiber	11-15, 31-35, 51-55, 71-75	579-601	579-601	579-601
		Teflon	21-25	579-30	579-30	579-30
8	Washer	Aluminum	11-15, 21-25	241-108	241-108	241-108
		316 SS	31-35, 51-55, 71-75	241-53	241-53	241-53
9	Wing Nut	18-8 SS	All	213-85	213-85	213-85
10	ESNA Nut	18-8 SS	All	SP611-A	SP611-A	SP611-A
11	Wing Nut	18-8 SS	All	213-85	213-85	213-97
12	Vacuum & Pressure Seat	Phenolic	11-15, 31-35	9402-15681	851185-002	851185-003
		Aluminum	21-25	9402-14241	9402-14242	9402-14243
		316 SS	51-55, 71-75	9402-13800	9402-13050	9402-13060
13	Vacuum Screen	Galv. Steel	11-15, 21-25	851112-001	851112-002	851112-003
		304 SS	31-35, 51-55, 71-75	851112-008	851112-009	851112-010
14	Loading Wtg.	Lead, Steel, SS	All	For Ref. Only. Call Factory if Required		
15	Vacuum Pallet Stem	Aluminum	Based on Table IV	9402-15962	9402-15992	9402-16002
		316 SS	(Set Point) C.F.	9402-15980	9402-15990	9402-16000
16	Retaining Plate	Aluminum	11-15, 21-25	851109-001	851109-002	851109-003
		316 SS	31-35, 51-55, 71-75	851109-008	851109-009	851109-010
17	Pallet (P/V)	Aluminum	11-15, 21-25	851133-001	851133-002	851133-003
		316 SS	31-35, 51-55, 71-75	851262-001	851262-002	851262-003
18	VAC Pallet Side Guide	316 SS	All	9402-16052	9402-16050	9402-16070
19	Hood	SS	All	9402-13400	9402-13420	9402-13440
20	Pressure Pal Stem	Aluminum	11-12, 21-22	851637-001	---	---
		316 SS	23-25, 31-35, 51-55, 71-75	851637-004	851637-002	851637-003
21	Pressure Screen	Galv. Steel	13-15, 11-15	851156-001	851156-002	851156-003
		304 SS	31-35, 51-55, 71-75	851156-008	851156-009	851156-011
22	Pallet Side Guide	316 SS	All (CV)	853226-001	853225-001	851525-003
23	Pallet Side Guide	316 SS	All (CV)	851525-001	851525-002	851525-003
24	Flange Gasket	N8090	11-71, 13-73	248-15	248-10	241-21
25	Cable	316 SS	All (Snuffer)	9402-10580	9402-10580	9402-10580
				Specify Tank Height		
26	Seal (Liquid)	Loctite	All	SP364-A	SP364-A	SP364-A
27	ESNA Nut	18-8 SS	All (CV)	SP461-F	SP461-F	SP461-G
28	Nut	18-8 SS	All	226-1	226-1	226-3
30	Pallet	Aluminum	All	9402-16952	9402-16962	9402-16972
		316 SS	All (Set Point <5" WC)	9402-16951	9402-16961	9402-16970
		316 SS	All (Set Point >5" WC)	9402-16950	9402-16960	9402-16971
31	Spacer	N8090	All	9402-17430	9402-17430	9402-17430
32	Backup Disc	N8090	All	9402-17290	9402-17300	9402-17310
33	Diaphragm	.005 FEP Teflon	All (Set Point <5" WC)	9402-17220	9402-17230	9402-17240
		.010 FEP Teflon	All (Set Point >5" WC)	9402-17221	9402-17231	9402-17241
34	Clamp Ring	Aluminum	All	9402-17021	9402-17030	9402-17041
		316 SS	All	9402-17020	9402-17031	9402-17040
35	Retainer Plate	Aluminum	All	851109-015	851109-001	851109-002
		316 SS	All	851109-016	851109-008	851109-009
36	Washer	Fibre	All	579-14	579-14	579-14
37	#4 Washer	18-8 SS	All	SP322-B	SP322-B	SP322-B
38	#4 40 Nut	18-8 SS	All	SP330-E	SP330-E	SP330-E
39	#4 40 x 5/8" Screw	18-8 SS	All	SP329-DJ	SP329-DJ	SP329-DJ

# Parts Drawing For 2",3"&4" Breather Valve

Xpand-o-Seal Pallet Assembly



Open Vent Model

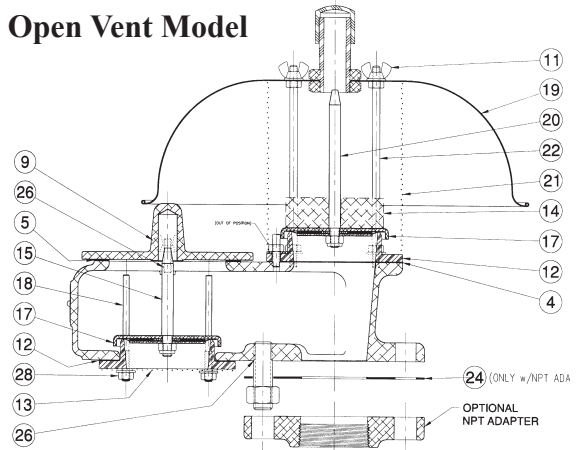


Figure 5B.

Closed Vent Model

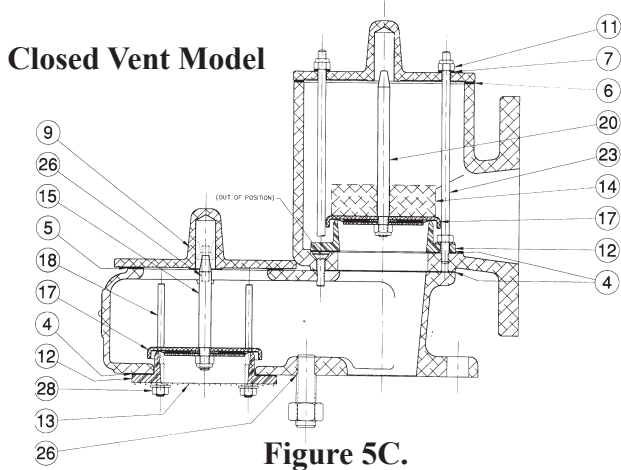
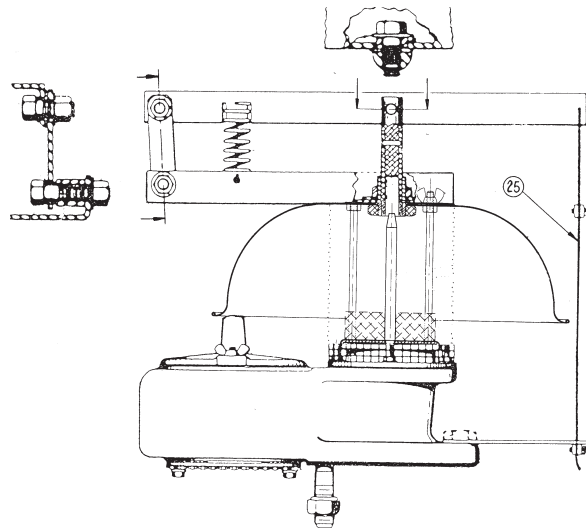


Figure 5C.



Open Vent Model With Flame Snuffer

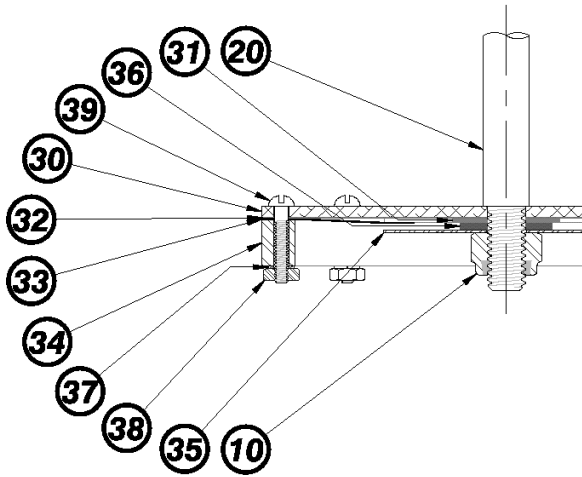
Figure 5D.

Item No.	Description	Material	Used in Table 1 Option No.	Part No.			
				6"	8"	10"	12"
1	Diaphragm	.005 Teflon	All (Set Point<5" W.C.)	851786-004	851786-005	851786-006	851786-007
		.010 Teflon	All (Set Point<5" W.C.)	851786-001	851786-012	851786-013	851786-014
2	Back up Disc	N8090	All	851105-004	851105-005	851105-006	851105-007
3	Spacer	Cork	16,19	851445-004	851445-005	851445-006	851445-007
		N8090	26-29,36-39,56-59,76-79	851445-001	851445-012	851445-013	851445-014
4	Sealant, Seat Gasket Seat	Permatex #2	16-19,36-39,56-59,76-79	SP390-A	SP390-A	SP390-A	SP390-A
		N8090	26-29	852872-001	852873-001	852874-001	852875-001
5	VAC, Cover O-Ring	Buna "N"	All	SP518-QQ	SP518-QW	SP518-RE	SP518-RC
		Viton	All	SP354-QQ	SP354-QW	SP354-RE	SP354-RC
6	CV Cover Gasket	N8090	All	9402-12980	9402-12981	9402-12982	9402-12983
7							
8	Washer	Aluminum	16-19,26-29	241-108	241-108	241-108	241-108
		18-8 SS	36-39,56-59,76-79	241-53	241-53	241-53	241-53
9	Nut	18-8 SS	All	226-3	226-13	226-28	226-28
10	ESNA Nut	18-8 SS	All	SP611-A	SP611-A	SP611-A	SP611-A
11	Wing Nut	18-8 SS	All	213-85	213-85	213-86	213-86
12	Vacuum& Pressure Seat	Phenolic	36-39	851185-004	851185-005	Note 1	851185-007
		Aluminum	16-19,26-29	851233-004	851233-005	851233-006	851233-007
13	Vacuum Screen	316SS	56-59,76-79	9402-13070	9402-13080	9402-13090	9402-13100
		Galv Steel	16-19,26-29	851112-004	851112-004	851112-004	851112-004
		18-8 SS	36-39,56-59,76-79	851112-011	851112-012	851112-013	851112-014
14	Loading Wtg.	Lead	All	For Ref. Only C.F., if Required			
15	Vacuum Pallet Stem	316SS	All	9402-16010	9402-16020	9402-16030	9402-16040
16	Retaining Plate	Aluminum	16-19,26-29	851109-004	851109-005	851109-006	851109-007
		316SS	36-39,56-59,76-79	851109-011	851109-012	851109-013	851109-014
17	Pallet (P/V)	Aluminum	16-19,26-29	851133-004	851133-005	851133-006	851133-007
		316SS	36-39,56-59,76-79	851262-004	851262-005	851262-006	851262-007
18	VAC Pallet Sideguide	316SS	All	9402-16080	9402-16090	9402-16100	9402-16110
19	Hood	18-8 SS	18-19,38-39,58-59,78-79			9402-13140	RBD4020-116
		18-8 SS	16-17,36-37,56-57,76-77	9402-13500	9402-13550		
20	Pressure OV	18-8 SS	All	9402-16400	9402-16410	9402-16420	9402-16430
	Pallet Stem CV	18-8 SS	All	9402-16440	9402-16450	9402-16420	9402-16430
21	Pressure Screen	Galv Steel	16-19,26-29	851156-004	851156-005	851156-006	851156-007
		304SS	36-39,56-59,76-79	851156-011	851156-012	851156-013	851156-014
22	Pallet Side Guide OV	316SS	All	9402-13510	9402-13540	851508-003	851508-004
		316SS	All			851638-003	851638-004
23	Pallet Side Guide	316SS	All	9402-12990	9402-13000	9402-13010	9402-13020
25	Cable	18-8 SS	All	9402-10580	9402-10580	9402-13010	9402-10580
				Specify Tank Ht.			
26	Sealant	Locking Compound Type A	All	SP364-A	SP384-A	SP364-A	SP364-A
28	Nut	18-8 SS	All	226-3	226-13	226-28	226-28
30	Pallet	Aluminum	All	9402-16982	9402-16990	9402-17000	9402-17012
		316SS	All (Set Points<5" W.C.)	9402-16981	9402-16991	9402-17001	9402-17011
		316SS	All (Set Points<5" W.C.)	9402-16980	9402-16992	9402-17002	9402-17010
31	Spacer	N8090	All	9402-17430	9402-17430	9402-17430	9402-17430
32	Backup Disc	N8090	All	9402-17320	9402-17330	9402-17340	9402-17350
33	Diaphragm	.005 FEP Teflon	All (Set Points<5" W.C.)	9402-17250	9402-17260	9402-17270	9402-17280
		.010 FEP Teflon	All (Set Points<5" W.C.)	9402-17251	9402-17261	9402-17271	9402-17281
34	Clamp Ring	Aluminum	All	9402-17051	9402-17060	9402-17070	9402-17081
		316SS	All	9402-17050	9402-17061	9402-17071	9402-17080
35	Retainer Plate	Aluminum	All	851109-003	851109-004	851109-005	851109-006
		316SS	All	851109-010	851109-011	851109-012	851109-013
36	Washer	Fibre	All	579-14	579-14	579-14	579-14
37	#4 Washer	18-8SS	All	SP322-B	SP322-B	SP322-B	SP322-B
38	#4-40 Nut	18-8SS	All	SP330-E	SP330-E	SP330-E	SP330-E
39	#4-40 x 3/4" Screw	18-8SS	All	SP329-DK	SP329-DK	SP329-DK	SP329-DK

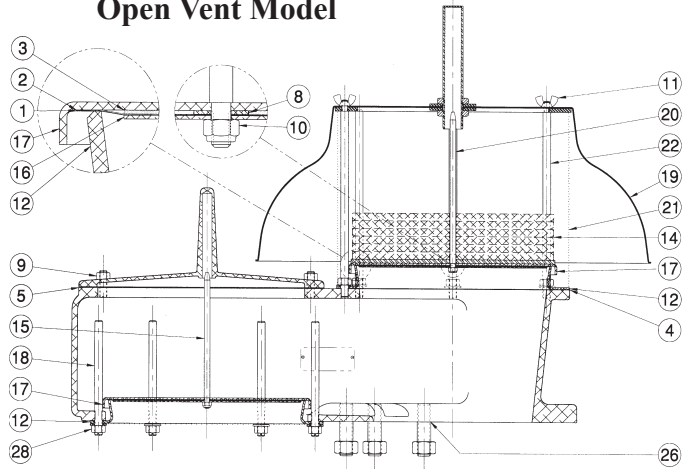
**Note 1.** 10" Phenolic Seat obsoleted. Use 851233-006(AL) or 9402-13090(316SS).  
Teflon coated seats available upon special request.

# Parts Drawing For 6",8",10",&12" Breather Valve

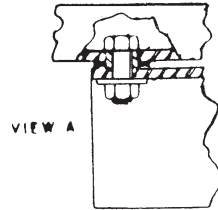
**Xpand-o-Seal Pallet Assembly**



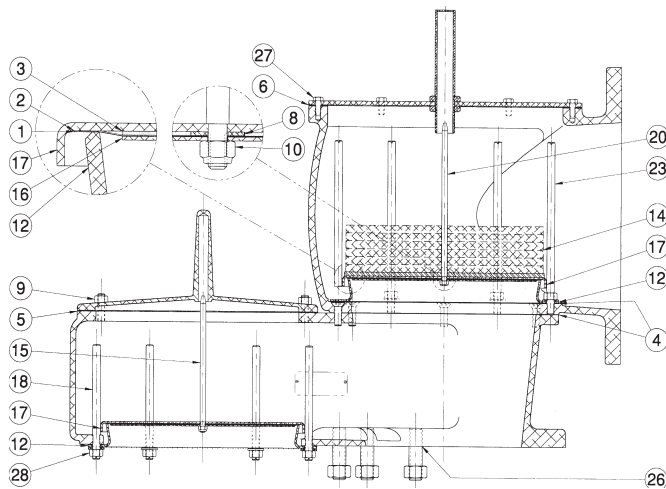
**Open Vent Model**



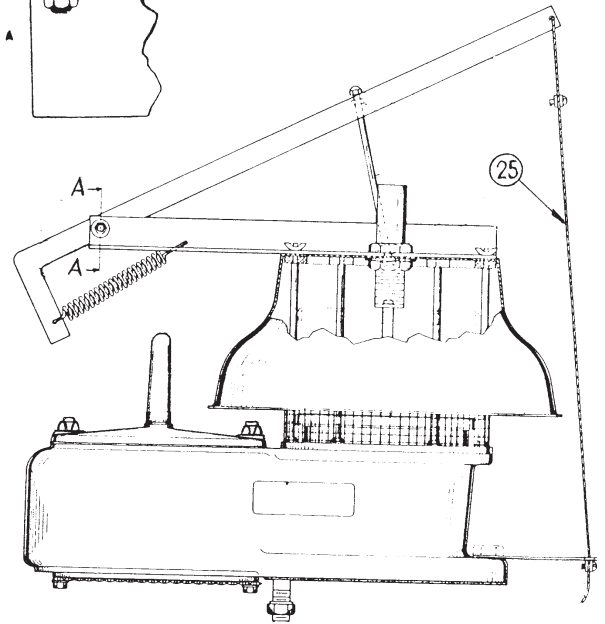
**Figure 6B.**



**Closed Vent Model**

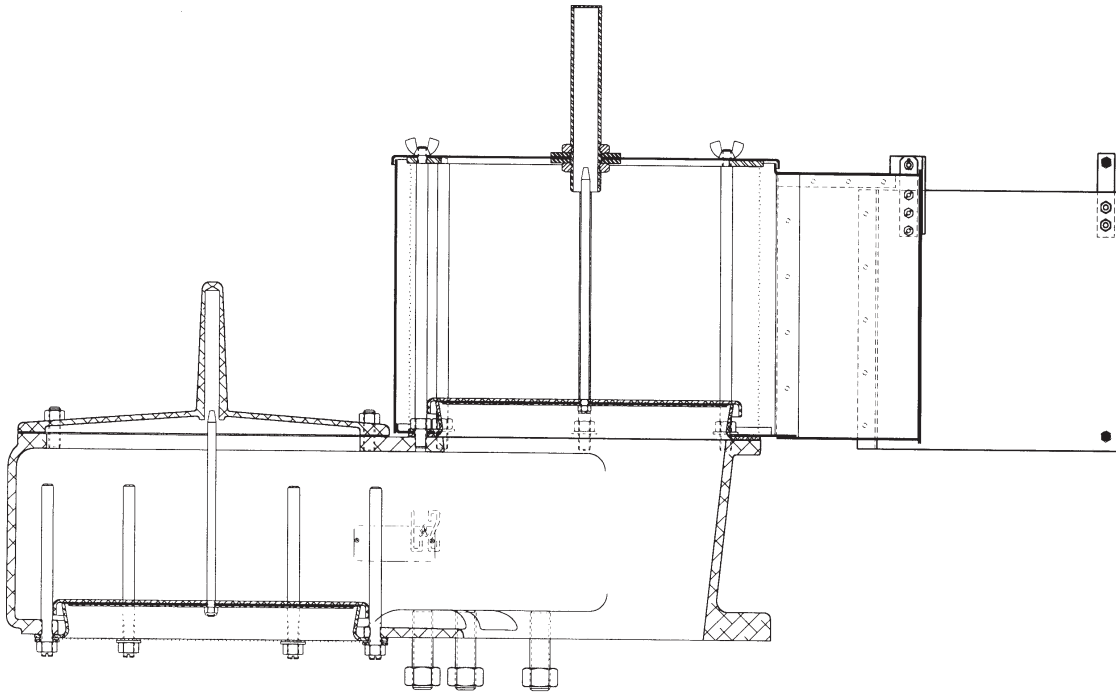


**Figure 6C.**



**Open Vent Model With Flame Snuffer  
Figure 6D.**

# Parts Drawing 6",8",10",&12" Breather With Cryogenic Hood



**Figure 7.**

## NOTES

1. Triangle in Chart Showing Recommend Spare Part with item no. for standard parts.
2. All parts are degreased before assembly; unit is assembled with extra care to keep all parts clean.
3. 0.010" diaphragm is used for loadings over 5 In. W.C.
4. Both surfaces of gasket item 5 (when used) are coated with Halocarbon (oxygen service only).
5. Steel hardware is plated for corrosion resistance.
6. If posts have been removed, rotate them on reassembly (360 degrees) so that pallet lays flat on seat. Seal threads with item 26 or Halocarbon.
7. Use care in ordering, spare parts. Always provide model and serial numbers when ordering.

*All designs subject to change. Certified dimensions and specifications available upon request.*

# Closed Vent Model with Integral Seat

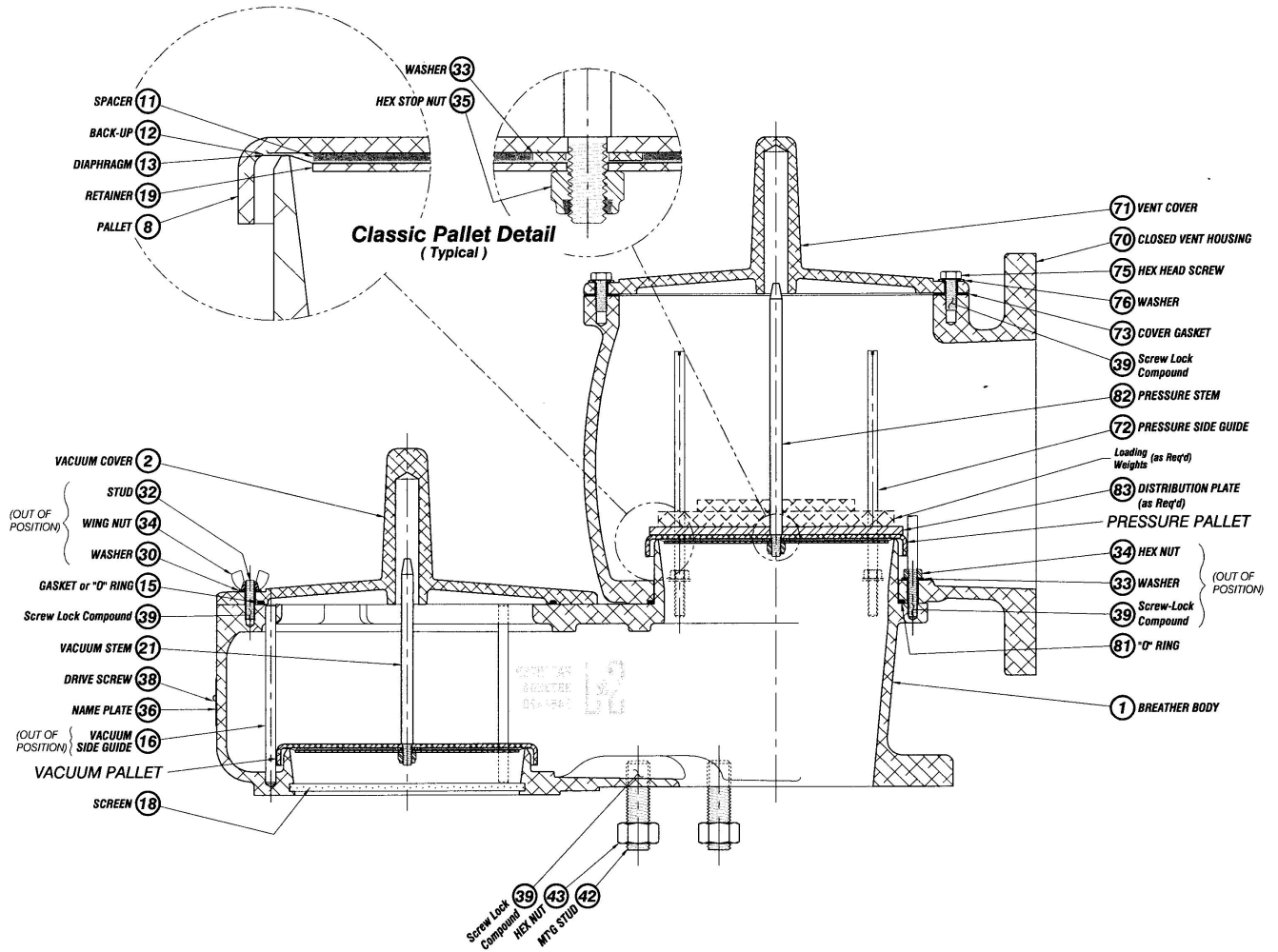


Figure 8.

\*Consult factory for part numbers. Provide factory with model number of valve. Elevated pressure settings use reinforced vacuum pallet. See Figure 10.

# Open Vent Model with Integral Seat

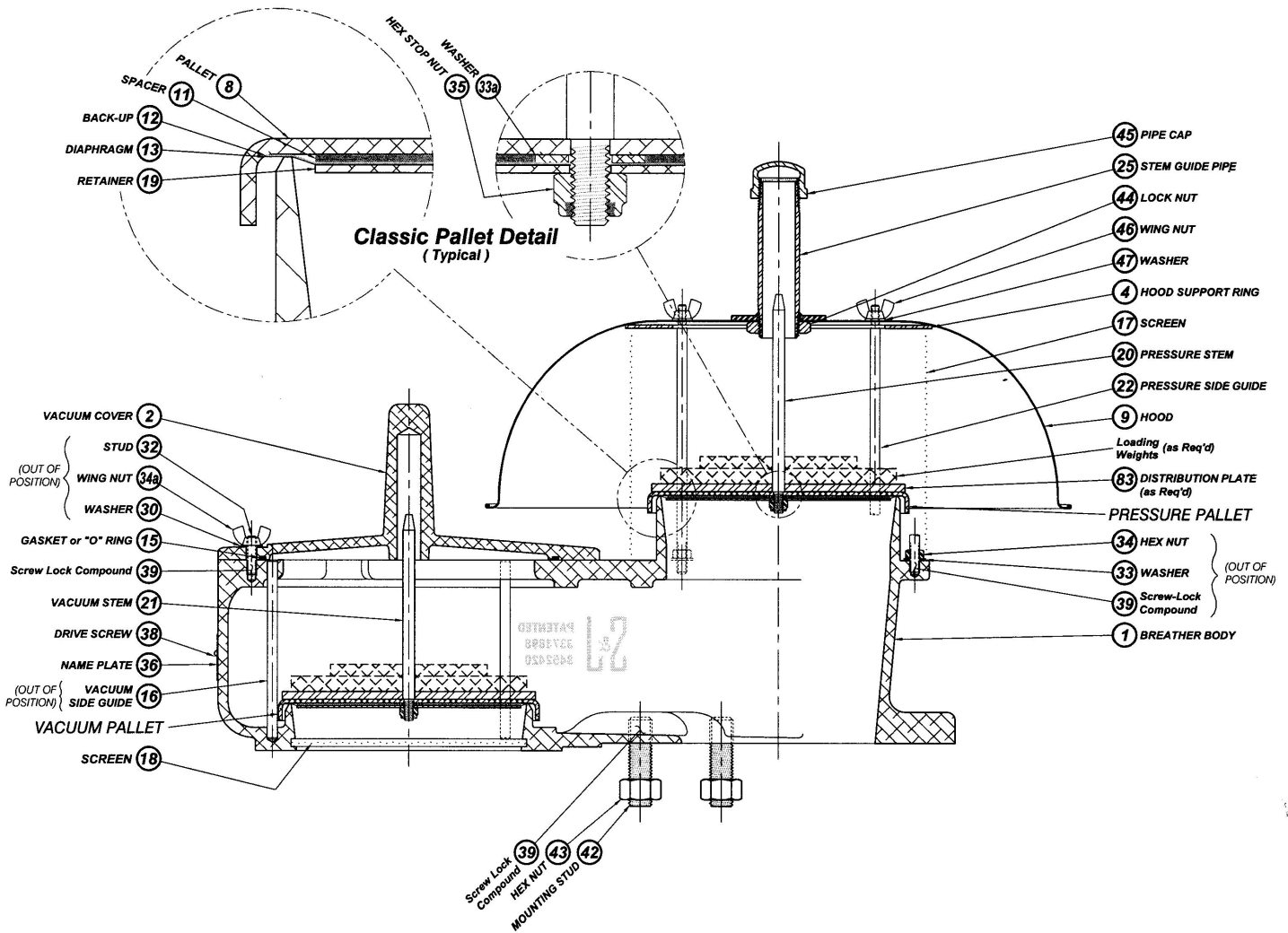
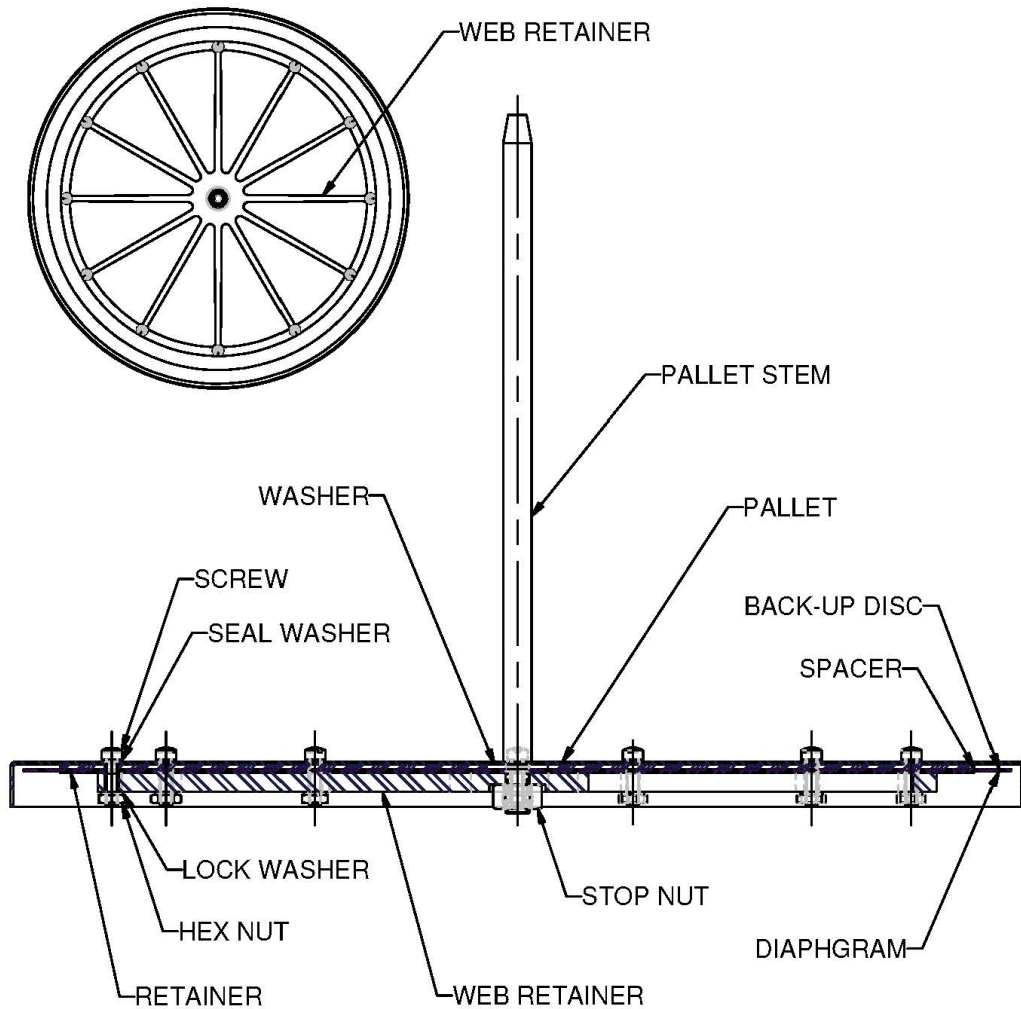


Figure 9.

\*Consult factory for part numbers. Provide factory with model number of valve. Elevated pressure settings use reinforced vacuum pallet. See Figure 10.



**VACUUM REINFORCED PALLET CONFIGURATION  
FOR HIGH BACKPRESSURE & LOW SET POINT**

CONSULT FACTORY FOR PART NUMBERS.  
PROVIDE FACTORY WITH MODEL NUMBER OF VALVE.

**Figure 10.**

## Air-Groove Pallet Assembly

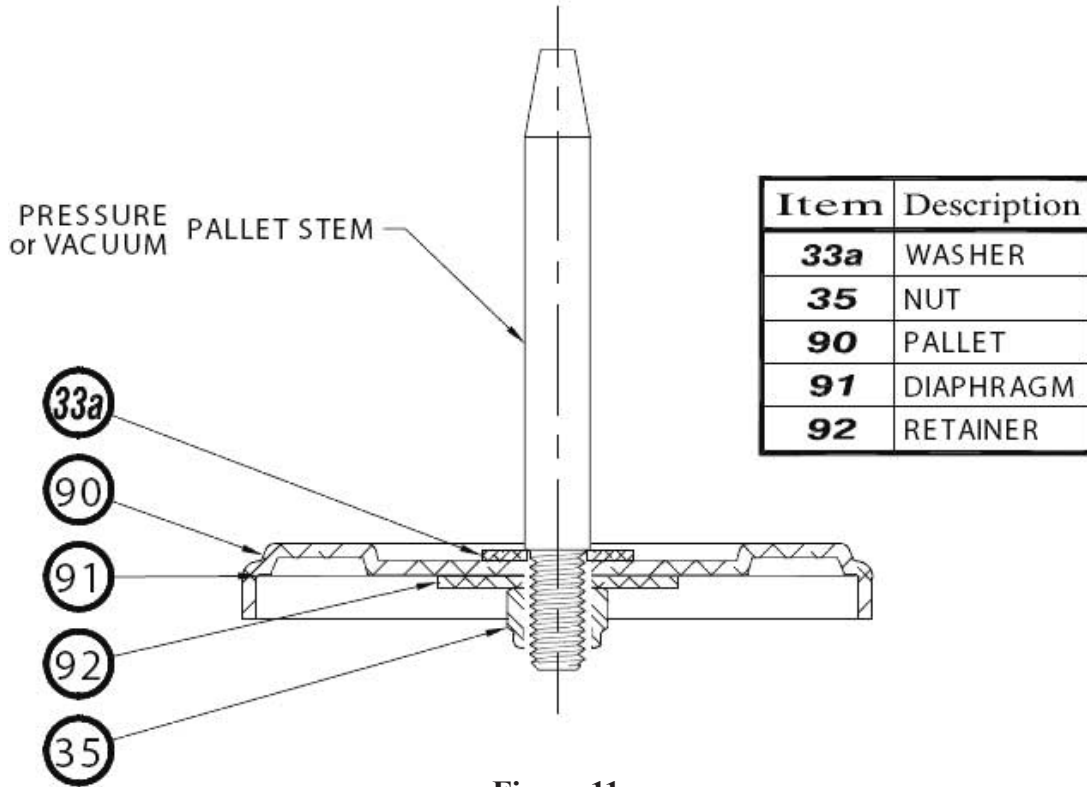


Figure 11.

Item No.	Description	Material	Part No						
			2"	3"	4"	6"	8"	10"	12"
33a	Washer	AL	241-108	241-108	241-108	241-108	241-108	241-108	241-108
		316 SS	241-53	241-53	241-53	241-53	241-53	241-53	241-53
35	Nut		SP611-A	SP611-A	SP611-A	SP611-A	SP611-A	SP611-A	SP611-A
90	Air Groove Pallet	AL	9402-18560	9402-18660	9402-18620	9402-18422	9402-18630	9402-18640	9402-18650
	Air Groove Pallet	316 SS	9402-18740	9402-18750	9402-18760	9402-18770	9402-18780	9402-18790	9402-18800
91	Air Groove Diaphragm	.010 FEP Diaph. f/Alum. Pallet	9402-18670	9042-18680	9402-18690	9402-18700	9402-18710	9402-18720	9402-18730
	Air Groove Diaphragm	.020 FEP Diaph. f/Alum. Pallet	9402-18672	9402-18682	9402-18692	9402-18702	9402-18712	9402-18722	9402-18732
	Air Groove Diaphragm	.010 FEP Diaph. f/S.S. Pallet	9402-18670	9402-18860	9402-18870	9402-18700	9402-18880	9402-18890	9402-18900
	Air Groove Diaphragm	.020 FEP Diaph. f/S.S. Pallet	902-18672	9402-18862	9402-18872	9402-18702	9402-18882	9402-18892	9402-18902
92	Air Groove Pallet Retainer	AL	851109-015	851109-001	851109-002	851109-003	851109-004	851109-005	851109-006
	Air Groove Pallet Retainer	316 SS	851109-016	851109-008	851109-009	851109-010	851109-011	851109-012	851109-013



**NOTE:** Air groove pallet does not use space washer. The buna and viton diaphragms use standard teflon diaphragm for back-up disc (not shown). Consult Factory for the correct diaphragm (Item 91) for your model number and set point.



5911 Butterfield Road • Hillside, Illinois 60162  
Phone: (708) 236-6000 • Fax: (708) 236-6006  
[www.ljtechnologies.com](http://www.ljtechnologies.com)

All designs subject to change. Certified dimensions and specifications available upon request.

## SAFETY INFORMATION

Before proceeding, any addendum along with the instruction manual must be fully read and understood. Periodically throughout this manual, the words Danger, Warning, Caution and Note may occur. These are reminders to be especially careful. See the descriptions below for more details on what each word denotes.



### DANGER

Indicates an imminently hazardous situation which, if not avoided, "will" result in death or serious injury. This word is limited to the most extreme situations.



### WARNING

Indicates a potentially hazardous situation which, if not avoided, "could" result in death or serious injury.



### CAUTION

Indicates a potentially hazardous situation which, if not avoided, "may" result in minor or moderate injury, or damage to the instrument being worked on.



**Note:** Is meant to add some measure of help or give useful information to the person working on the instrument.

## GENERAL

This Shand & Jurs Flame Arrester acts as an end of line fire barrier between flammable liquids stored in low pressure tanks and its emitted combustible vapors. It provides a positive flame stop for flammable liquids or solvents having a flashpoint below 110°F (43°C), of flammable mixtures that reach a flashpoint under normal operating conditions.

In addition to providing exceptional protection against fire from an external ignitable source, it also allows maximum vapor flow with minimum pressure drop.

Temperature of the flammable vapor passing through the arrester's tube bank (shown in figure 2) is kept below its flashpoint thereby preventing combustion. The tube bank consists of alternating flat and corrugated sheet stock spiral-wound around a solid core. It is contained in a shell that is positioned between the arrester's body sections. Tie bolts are used to secure the body sections together. When the shell is to be removed for cleaning, periodic inspection or maintenance, the tie bolts are used as jacking screws to separate the body sections from the shell.



**FIGURE 1: MODEL 94306 FLAME ARRESTER**

The standard flame arrester is Factory Mutual (FM) approved when mounted with a vent to atmosphere pipe downstream of the flame arrester not greater than 10 pipe diameters long.

## RECEIVING

This shipment is the property of the purchaser when it leaves our plant. Shand & Jurs cannot be responsible for any damage or loss during transit. Any claim must be reported to the transportation company. If a shipment is received incomplete or damaged, notify the transportation company at once, preserve shipping crate, packing slip and contents as received. Failure to properly describe evidence of loss or damage to carrier may result in the carrier refusing to honor claim.

Shand & Jurs shipping procedures have been proven by years of experience. Your equipment is thoroughly inspected before leaving our plant and is carefully crated in compliance with carrier regulations. The carrier contracted, assumes responsibility for delivery upon acceptance of shipment.

## MODEL NUMBER IDENTIFICATION

Your equipment is identified by a Shand & Jur's model number stamped on the nameplate. Options such as material construction, raised or flat face flange and etc. are part of the Model Number. Refer to the following Model Number Breakdown to determine the options in your equipment.

When ordering replacement parts, use the complete model number, part description and its related part number.

## MODEL NUMBER BREAKDOWN

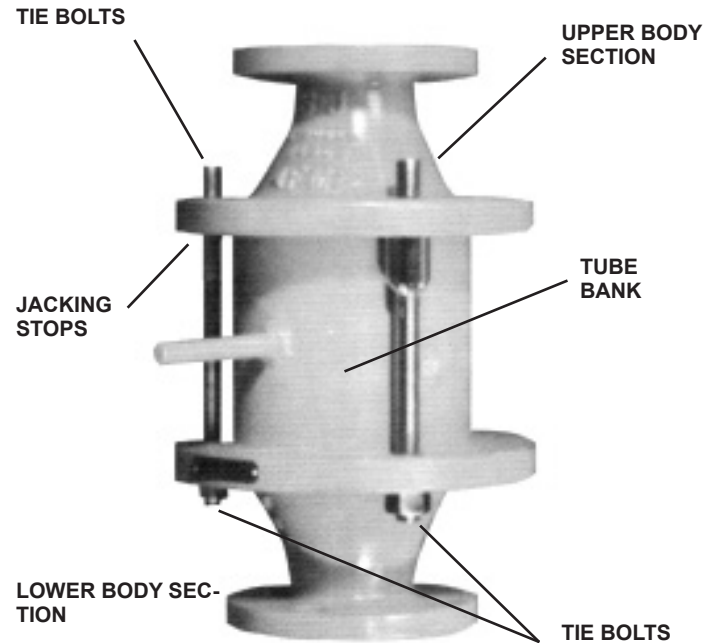
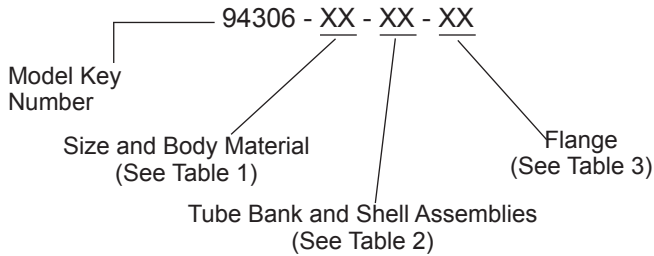


FIGURE 2: PARTS ILLUSTRATION

TABLE 1- SIZE AND BODY MATERIAL

SIZE	DESCRIPTION / OPTION NUMBER				
	Cast Aluminum	Cast Iron	316 S.S.	Cast Steel	Ductile Iron
2	12	32	42	52	62
3	14	34	44	54	64
4	15	35	45	55	65
6	16	36	46	56	66
8	17	37	47	57	67
10	18	38	48	58	68
12	19	39	49	59	69

TABLE 2 - TUBE BANK

DESCRIPTION	OPTION NUMBER
Aluminum Element and Shell	11
316 Stainless Steel Element and Shell	22
304 Stainless Steel Element and Carbon Steel Shell	66

TABLE 3 - FLANGE

DESCRIPTION	OPTION NUMBER	
	No Drain Plug	With Drain Plug
150 Lb. ANSI Flat Face Flange	77	71
150 Lb. ANSI Raised Face Flange (not offered for cast aluminum body, noted in Table 1)	87	81



Note: Model 94306 Flame Arresters are designed to withstand static pressure up to 5 PSI. DIN and JIS10K Flange Connections available.

## INSTALLATION

The flame arrester is generally installed on an open vent pipe from storage or processing tanks, bleed lines, bleed tanks or other waste gas devices. The flange of the flame arrester is either a flat face or 1/16" raised face to fit 150 pound flanges. When mounting a raised face flange, be extremely careful when tightening its mounting bolts so flange does not crack. Refer to figure 3 for dimensions of arrester to be installed making sure sufficient clearance is allowed to enable tube bank to be removed. Mount arrester as follows.

1. Remove vent cover or others (if present) from tank nozzle or vent pipe on which arrester is to be mounted. Discard old flange gasket.
2. Place new gasket on tank nozzle or vent pipe. Cut away any gasket material that may extend into vapor flow passage.
3. Place arrester over new gasket. Position arrester so the mounting holes are aligned and its handle is accessible enabling tube bank to be removed for maintenance or replacement.
4. Bolt arrester securely in place.
5. Attach free vent, breather valve or others onto top of arrester using instruction manual supplied with unit.

### **WARNING**

Any vent pipe downstream of the flame arrester must not be greater than 10 pipe diameters long.

## MAINTENANCE

It is recommended to inspect the bank quarterly or at least biannually for the first year after installation and clean the tube bank whenever inspection shows the need.

These inspections and the frequency of cleaning will provide the basis to establish a predetermined maintenance program. As a minimum inspect the tube bank annually.

### **WARNING**

1. Before performing any maintenance, the inside of the storage tank or vent line must be at atmospheric pressure and free of hazardous atmosphere.
2. If tube bank is damaged, the tube bank must be replaced as a complete assembly. Under no circumstance should the tube be disassembled from its shell for cleaning or replacement.

1. Remove pressure in storage tank or line containing flammable liquid to atmosphere.
2. Remove one tie bolt (without jacking nut) on 2-inch and 3-inch flange sizes and two tie bolts on all other flange sizes.
3. Turn jacking nuts, each a little at a time to evenly separate the body sections of flame arrester. Continue turning jacking nuts in this manner until there is just enough clearance to free tube bank from upper body section. Refer to dimension drawing figure 3.

4. Grasp handle on tube bank and slowly pull forward until approximately three quarters of tube bank is exposed. Do not completely remove tube bank from arrester. Leave tube bank in far enough permitting lower body section to support weight of tube bank.
5. Inspect for dirt, tar, gum or other residues clogging tube bank corrugations. If tube bank must be cleaned, refer to Cleaning subparagraph below.

## CLEANING

Refer to removal and replacement section to separate tube bank from arrester for cleaning or replacement. Inspect corrugations of tube bank to determine type of residue clogging it. Use one of the following procedures: A, B, or C that list clogging substance to clean tube bank. If suggested procedure is not successful, check to see if substance is also listed in another procedure.

### **CAUTION**

When substance is not removed using a particular procedure, replace with new tube bank to avoid risk of damage to tank and possible loss of product since clogging prevents tank venting.

### **WARNING**

Handle volatile and flammable solvents with care to avoid ignition or prolonged breathing.

## CLEANING PROCEDURE A

### Clogging Substances:

Soil, sand, pollen and metallic salts.

### Cleaning Method:

1. Wash with mild solvent such as kerosene, gasoline, petroleum naphtha, or commercial petroleum derived cleaning fluids.
2. Rinse in a solvent that will not leave an oily film which can collect foreign matter.
3. Use compressed air to blow-out substance from tube bank.
4. Wash with hot water
5. Steam clean

## CLEANING PROCEDURE B

### Clogging Substances

Metallic oxides and metallic carbonates.

### Cleaning Method

1. Perform step 1 of Cleaning Procedure A.
2. Soak the tube bank in cold 35% nitric acid only if tube bank and shell assemblies are all aluminum or stainless steel. Nitric acid quickly destroys monel or carbon steel.

If clogging substance is still present, place tube bank in boiling 35% nitric acid.

### **WARNING**

Use protective clothing and glove when using acid. Serious burns will result when acid contacts skin.

3. After tube bank is clean, submerge in a solution of baking soda and water (8 ounces of baking soda to 3 gallons of water) to neutralize any acid remaining on tube bank.
4. Blow dry using compressed air.

## CLEANING PROCEDURE C

### Clogging Substances:

Organic tars, organic gums and organic or sulphur residues.

### Cleaning Method

1. Perform step 1 of Cleaning Procedure A.
2. Blow out with compressed air.
3. Wash with a strong solvent such as benzol, xylol, carbon tetrachloride, acetone, carbon disulphide, paint thinner (not lacquer thinner), or a mixture of 1/3 each of benzol, alcohol and acetone.

## REMOVAL AND REPLACEMENT

The tube bank is secured between the body sections of the flame arrester with tie-bolts. Depending on the flame arrester's flange size, only one or two tie-bolts are removable. The remaining tie-bolts are fitted with jacking nuts to separate the body sections of the flame arrester thereby allowing the tube bank to be removed.

### **CAUTION**

The 10-inch and 12-inch steel tube bank weighs approximately 185 lbs. Failure to use adequate equipment such as a portable hoist or adequate manpower may cause injury to persons or property.

1. Make sure vapor pressure in the storage tank or line is at atmospheric pressure and free of hazardous atmosphere.
2. Remove one tie-bolt (without jacking nut) on 2-inch and 3-inch flame arrester flange sizes and two on all other flange sizes.
3. Turn jacking nuts, each a little at a time to evenly separate the body sections of flame arrester. Continue turning jacking nuts in this manner until there is just enough clearance to free tube bank from upper body section. Refer to dimension drawing figure 3.
4. Remove tube bank from a small flame arrester (flange sizes 2-inch thru 8-inch), by grasping tube bank handle and pulling forward until tube bank is free from flame arrester. On larger flame arresters (flange sizes 10-inch and 12-inch) use adequate equipment or manpower to remove tube bank.

### **WARNING**

When removing or installing the tube bank exercise extreme care not to damage corrugated sheet stock inside tube bank.

5. Insert new tube bank or one that has been cleaned in the reverse order as removed. Again exercise care not to damage corrugations inside tube bank.

## PARTS LIST

Order parts through the nearest Shand & Jurs office, representatives or distributor or direct from our factory.

When ordering replacement parts, be sure to use the complete equipment model number, description of the part being ordered and its related part number. Make sure the model number contains all option numbers as described in the Model Number Identification Paragraph.

### TUBE BANK AND SHELL REPLACEMENT ASSEMBLIES

MATERIAL		SIZE (Inches)	PART NUMBER
BANK	SHELL	2	9430-10150
ALUMINUM	ALUMINUM	3	9430-10151
		4	9430-10152
		6	9430-10153
		8	9430-10154
		10	9430-10155
		12	9430-10156
304 STAINLESS STEEL	CARBON STEEL	2	091211
		3	091212
		4	091213
		6	9430-11070
		8	9430-11071
		10	9430-11072
316 STAINLESS STEEL	316 STAINLESS STEEL	12	9430-11073
		2	9430-11110
		3	9430-11111
		4	9430-11112
		6	9430-11113
		8	9430-11114
		10	9430-11115
		12	9430-11116

# OUTLINE DIMENSIONS - ANSI OPTION

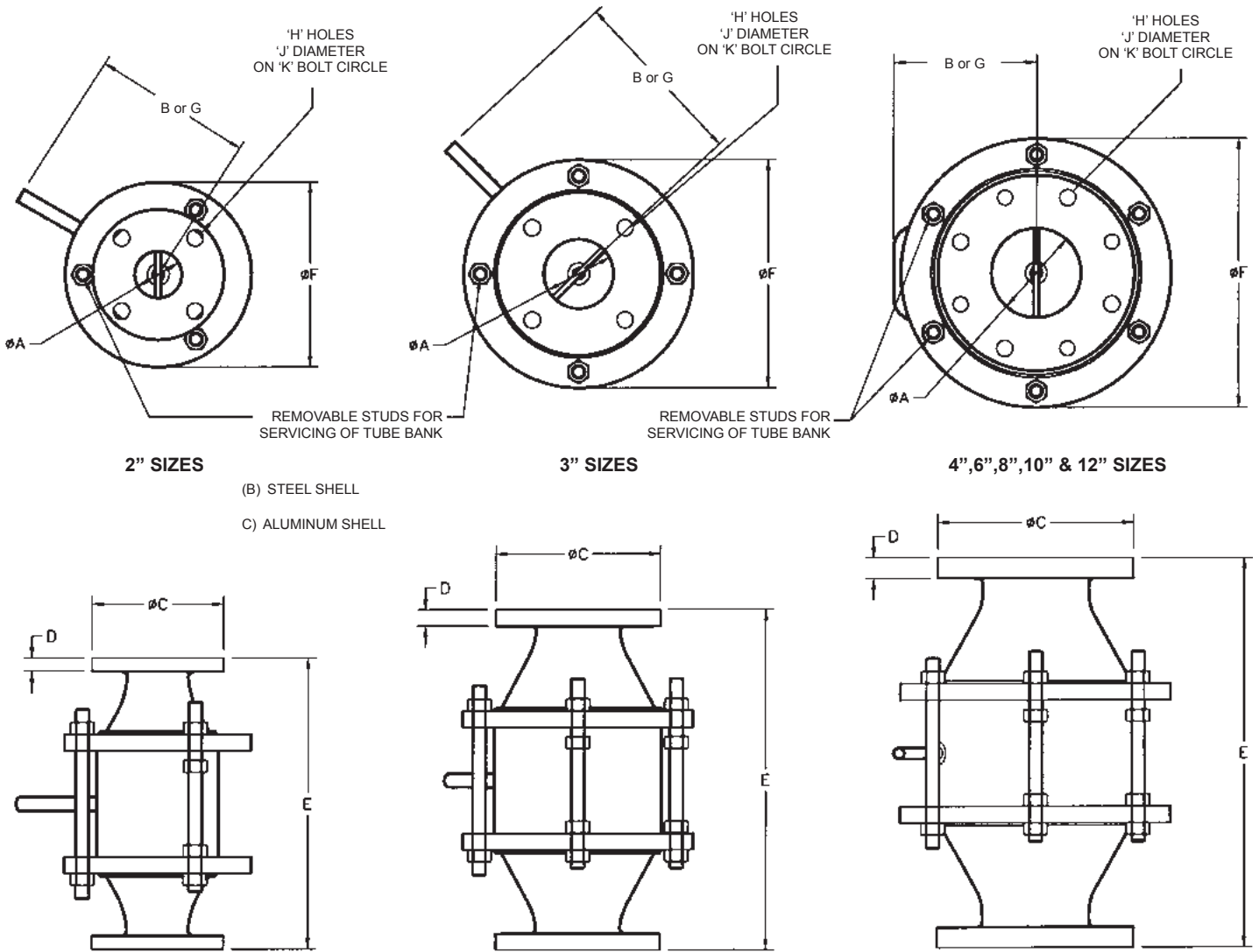


TABLE OF DIMENSIONS-INCHES										
SIZE	A	B	C	D	E	F	G	H	J	K
2	2-5/32	7-7/16	6	5/8	13-3/8	8-1/2	6-13/16	4	3/4	4-3/4
3	3-3/16	8-5/16	7-1/2	3/4	15-5/8	10-1/2	7-13/16	4	3/4	6
4	4-1/8	6-1/2	9	15/16	17-7/8	12-3/8	7-1/32	8	3/4	7-1/2
6	6-1/4	8-1/4	11	1	19-7/8	16-3/8	8-11/16	8	7/8	9-1/2
8	8-3/16	10-3/8	13-1/2	1-1/8	24-1/2	20-1/2	10-15/16	8	7/8	11-3/4
10	10-1/8	12-1/4	16	1-3/16	28-7/8	24-1/2	12-3/4	12	1	14-1/4
12	12-1/8	14-3/8	19	1-1/4	32-7/8	28-3/4	14-3/8	12	1	17

THIS PAGE INTENTIONALLY LEFT BLANK



All designs subject to change. Certified dimensions and specifications available upon request.

**5911 Butterfield Road • Hillside, Illinois 60162**  
**Telephone: (708) 236-6000 • Fax: (708) 236-6006**

# SHAND & JUR'S

## QUALITY CONTROL TECHNICAL DATA SHEET

RA800-543

SHAND&JURS  
An L&J Technologies Company

ORDER TJ2290  
ITEM 07

PART#: 97570=180718AD1 10"AL|AL:TB&SH|WS|XOS|IW|SS:TR

DATE: 12/20/2017

PRESSURE SETTING: 12.000 inWC 12.00 W.C XOS X @ 95 % 11.40 W.C

VACUUM SETTING: 2.000 inWC 2.00 W.C STD X @ 75 % 1.50 W.C

**TEST PROCEDURE:**

Immerse arrester in water and apply air pressure

PASSED BUBBLE TIGHT TEST Y

SERIAL NUMBER	ACTUAL INCHES W.C		LEAKAGE NOT TO EXCEED CU.FT/HR		ADDED LOADING PRESSURE				WEIGHT VACUUM		QC REL FOR SHIP
	PRESSURE	VACUUM	PRESSURE	VACUUM	LB	OZ	LB	OZ			
17512043	12.00	2.00	.50	1.50	50	15.0	5	11.0	MG		

TAG NUMBER:

PRESSURE PALLET

VACUUM PALLET

Distribution Plate

Assembly Weight: LB OZ

Assembly Weight: LB OZ

TESTED BY MOLLINEDO

# SHAND & JUR'S

## QUALITY CONTROL TECHNICAL DATA SHEET

RA800-543

SHAND&JURS  
An L&J Technologies Company

ORDER TJ2290  
ITEM 07

PART#: 97570=180718AD1 10"AL|AL:TB&SH|WS|XOS|IW|SS:TR

DATE: 12/20/2017

PRESSURE SETTING: 12.000 inWC 12.00 W.C XOS X @ 95 % 11.40 W.C

VACUUM SETTING: 2.000 inWC 2.00 W.C STD X @ 75 % 1.50 W.C

**TEST PROCEDURE:**

Immerse arrester in water and apply air pressure

PASSED BUBBLE TIGHT TEST Y

SERIAL NUMBER	ACTUAL INCHES W.C		LEAKAGE NOT TO EXCEED CU.FT/HR		ADDED LOADING WEIGHT				QC REL FOR SHIP
	PRESSURE	VACUUM	PRESSURE	VACUUM	LB	OZ	LB	OZ	
17512044	12.00	2.00	.50	1.50	50	15.0	5	11.0	MG

TAG NUMBER:

**PRESSURE PALLET**

**VACUUM PALLET**

Distribution Plate

Assembly Weight: LB OZ

Assembly Weight: LB OZ

TESTED BY MOLLINEDO

# SHAND & JUR'S

## QUALITY CONTROL TECHNICAL DATA SHEET

RA800-543

SHAND&JURS  
An L&J Technologies Company

ORDER TJ2290  
ITEM 07

PART#: 97570=180718AD1 10"AL|AL:TB&SH|WS|XOS|IW|SS:TR

DATE: 12/20/2017

PRESSURE SETTING: 12.000 inWC 12.00 W.C XOS X @ 95 % 11.40 W.C

VACUUM SETTING: 2.000 inWC 2.00 W.C STD X @ 75 % 1.50 W.C

**TEST PROCEDURE:**

Immerse arrester in water and apply air pressure

PASSED BUBBLE TIGHT TEST Y

SERIAL NUMBER	ACTUAL INCHES W.C		LEAKAGE NOT TO EXCEED CU.FT/HR		ADDED LOADING PRESSURE				WEIGHT VACUUM		QC REL FOR SHIP
	PRESSURE	VACUUM	PRESSURE	VACUUM	LB	OZ	LB	OZ			
17512045	12.00	2.00	.50	1.50	50	15.0	5	11.0	MG		

TAG NUMBER:

**PRESSURE PALLET**

Distribution Plate

Assembly Weight: LB OZ

**VACUUM PALLET**

Assembly Weight: LB OZ

TESTED BY MOLLINEDO

# SHAND & JUR'S

## QUALITY CONTROL TECHNICAL DATA SHEET

RA800-543

SHAND&JURS  
An L&J Technologies Company

ORDER TJ2290  
ITEM 07

PART#: 97570=180718AD1 10"AL|AL:TB&SH|WS|XOS|IW|SS:TR

DATE: 12/20/2017

PRESSURE SETTING: 12.000 inWC 12.00 W.C XOS X @ 95 % 11.40 W.C

VACUUM SETTING: 2.000 inWC 2.00 W.C STD X @ 75 % 1.50 W.C

**TEST PROCEDURE:**

Immerse arrester in water and apply air pressure

PASSED BUBBLE TIGHT TEST Y

SERIAL NUMBER	ACTUAL INCHES W.C		LEAKAGE NOT TO EXCEED CU.FT/HR		ADDED LOADING PRESSURE				WEIGHT VACUUM		QC REL FOR SHIP
	PRESSURE	VACUUM	PRESSURE	VACUUM	LB	OZ	LB	OZ	LB	OZ	
17512046	12.00	2.00	.50	1.50	50	15.0	5	11.0		MG	

TAG NUMBER:

**PRESSURE PALLET**

Distribution Plate

Assembly Weight: LB OZ

**VACUUM PALLET**

Assembly Weight: LB OZ

TESTED BY MOLLINEDO

9757-00010-10-TJ2290

THIS DISCLOSURE IS THE PROPERTY OF SHAND & JURTS, IS SUBJECT TO RETURN UPON DEMAND, AND IS MADE WITH THE UNDERSTANDING THAT IT IS NOT TO BE REPRODUCED, COPIED OR USED, DIRECTLY OR INDIRECTLY, IN ANY WAY DETRIMENTAL TO THE INTERESTS OF SHAND & JURTS, OR WITHOUT THE EXPRESS APPROVAL OF SHAND & JURTS.

**Notes:**

- 1) Connection matches 10"FF ANSI <sup>125</sup>/<sub>150</sub> Class Flange.
- 2) Dimensions expressed in INCHES [mm].
- 3) Max. Pressure 5 PSIG for 94306 Flame Arrester.

**97570 Combo Breather & Flame Arrester**

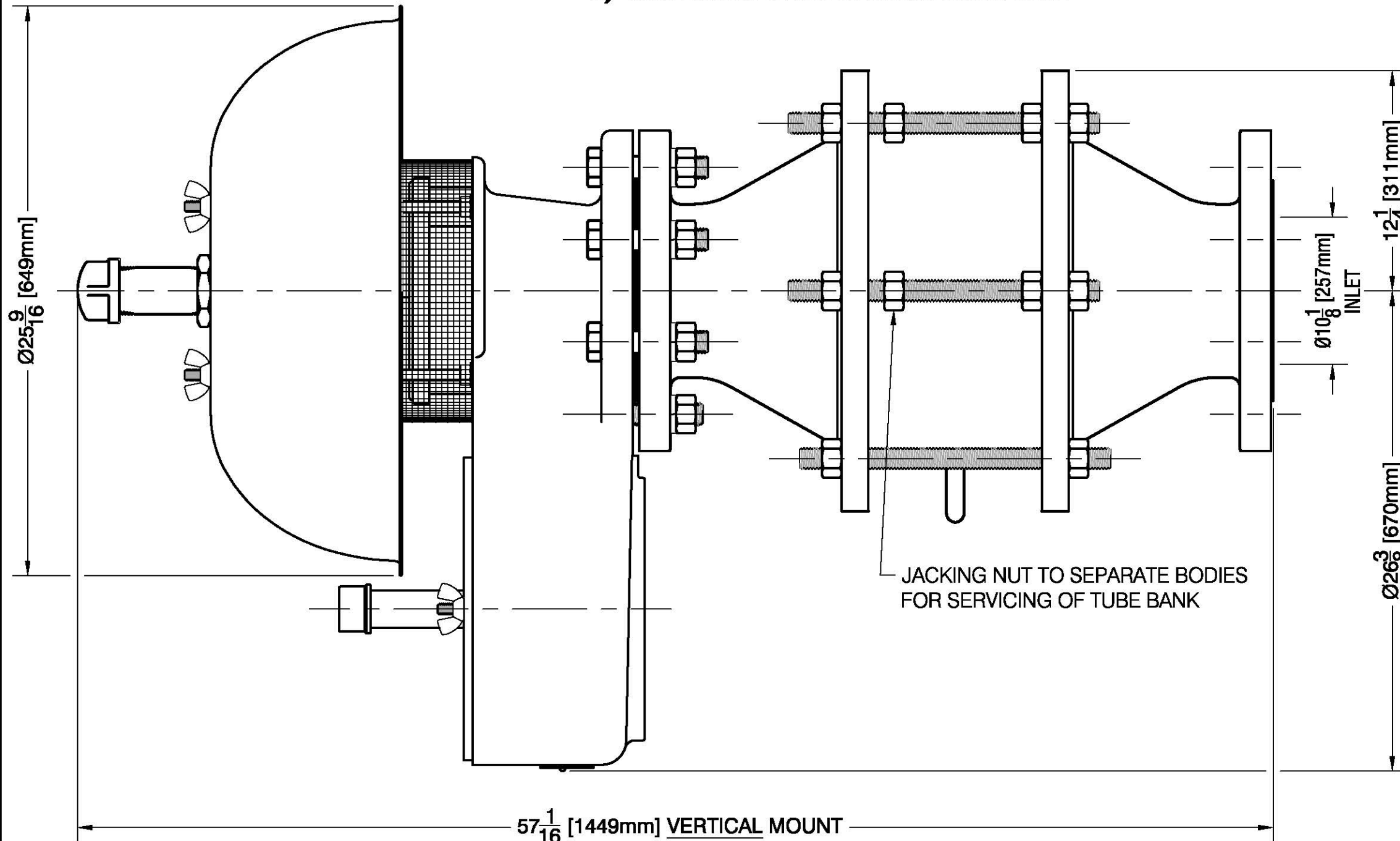
**Part Description: Material:**

- Body: B26-356 Cast Aluminum
- Seat ( Part of Body ): B26-356 Cast Aluminum\* (Teflon Coated)
- XOS Pallet: Aluminum\* (Teflon Coated)
- Guide Posts + Stem: 316 Stainless Steel\* (Teflon Coated)
- Screen: 316 Stainless Steel\* (Teflon Coated)
- External Hardware: 316 Stainless Steel
- Hood: Aluminum
- Weights: Lead; Incremental: 6"-16" W.C.  
9" W.C. in 1" W.C. Increments  
1/2" W.C. in (2) 1/4" W.C. Increments  
1/2" W.C. in (1) 1/2" W.C. Increments

- Diaphragm (Seat Insert): FEP Teflon
- Gaskets N-8090
- Cover O-Ring: Buna-N

- Flame Arrester Body: B26-356 Cast Aluminum
- Bank & Element: Aluminum
- Hardware: 316 Stainless Steel

\*All Weather Service: -30°F to 200°F  
(Special Teflon Coating  
Provides Antifreeze Protection)



57 <sup>1</sup>/<sub>16</sub> [1449mm] VERTICAL MOUNT

Max. Pressure Leakage Rate: 0.5 SCFH @ 95% of Set Pressure

**Flow Capacity (Min):**

Pressure: 85,480 SCFH @ 13.2" W.C. Set Point Plus 10% Over Pressure  
Vacuum: 25,490 SCFH @ -2.2" W.C. Set Point Plus 10% Under Vacuum

Pressure Setting: 12.0" W.C.  B  
Vacuum Setting: -2.0" W.C.

Cust. Tag No(s):           N/A          

PROJECT: 16-05 WW QC Facility Digester Improvements  
CUSTOMER: Western Water Constructors, Inc.  
CUSTOMER P.O. NO: 1605-03  
DESCRIPTION: Combo Breather & Flame Arrester  
MODEL NO: 97570=180718AD1  
SPECIFICATION: 11381 Section 2.10 & 2.11  
S&J SALES ORDER NO: TJ2290 DATE: Apr. 12, 2017

APPROVED  APPROVED  NOT APPR.-RESUB.   
CUST. SIGNATURE: \_\_\_\_\_ w/CHANGES PER COMMENT DATE: \_\_\_\_\_

A	Add Pressure S.P.	45	TKL	Apr 12 17	JJ
~	Release	3252	LSG	Mar 03 05	RJD
REV	DESCRIPTION	ECO	BY	DATE	APRV

**SHAND & JURTS**  
an L&J TECHNOLOGIES Company  
HILLSIDE, ILLINOIS USA  
**97570 Combo Breather + Flame Arrester**  
**10" Open Vent Dimensions**

DRWN	JJ	Type: Dim's	Size: B: 17 x 11
DATE	Mar 03 05	Scale: None	Designed: Standard
CHKD	LSG	T:\SO#\TJ2290\9757-00010-10-TJ2290.B.dwg	
APRV	TL	<b>9757-00010-10-TJ2290</b>	